

Split-Pipe Design of Water Distribution Network Using Simulated Annealing

J. Tospornsampan, I. Kita, M. Ishii, and Y. Kitamura

Abstract—In this paper a procedure for the split-pipe design of looped water distribution network based on the use of simulated annealing is proposed. Simulated annealing is a heuristic-based search algorithm, motivated by an analogy of physical annealing in solids. It is capable for solving the combinatorial optimization problem. In contrast to the split-pipe design that is derived from a continuous diameter design that has been implemented in conventional optimization techniques, the split-pipe design proposed in this paper is derived from a discrete diameter design where a set of pipe diameters is chosen directly from a specified set of commercial pipes. The optimality and feasibility of the solutions are found to be guaranteed by using the proposed method. The performance of the proposed procedure is demonstrated through solving the three well-known problems of water distribution network taken from the literature. Simulated annealing provides very promising solutions and the lowest-cost solutions are found for all of these test problems. The results obtained from these applications show that simulated annealing is able to handle a combinatorial optimization problem of the least cost design of water distribution network. The technique can be considered as an alternative tool for similar areas of research. Further applications and improvements of the technique are expected as well.

Keywords—Combinatorial problem, Heuristics, Least-cost design, Looped network, Pipe network, Optimization

I. INTRODUCTION

IN a water distribution network system, pipes are interconnected to form a complex loop configuration. A water distribution network problem is a nonlinear mixed integer problem that is cast in the combinatorial problem in which a set of solution is selected among a discrete set of feasible solution while the functions defined over it are nonlinear. The analytical solution of such problem is quite complicated because it involves simultaneous consideration of continuity equation, energy conservation, head-loss function, and avoidance of constraints violations.

J. Tospornsampan is with TEAM Consulting Engineering and Management Co., Ltd. 151 TEAM Building, Nuan Chan Rd., Khlong Kum, Bung Kum, Bangkok, 10230 Thailand (phone: 66-2-509-9000; fax:66-2-509-9045; e-mail: janejira_t@team.co.th).

I. Kita is with Faculty of Life and Environmental Science, Shimane University, Matsue, Shimane, 690-8504 Japan (e-mail: kita@life.shimane-u.ac.th).

M. Ishii is with Faculty of Life and Environmental Science, Shimane University, Matsue, Shimane, 690-8504 Japan (e-mail: ici@life.shimane-u.ac.th).

Y. Kitamura is with Faculty of Agriculture, Tottori University, Koyama-minami, Tottori, 680-8553 Japan (e-mail: ykita@muses.tottori-u.ac.jp).

There exists a large body of literature related to the optimal design of water distribution network problems. The linear programming gradient (LPG) method has long been recognized as the popular classical method for the design of looped water distribution network systems. The method was used extensively by many researchers (e.g., Alperovits and Shamir [1]; Quindry et al. [25, 26]; Goulter et al. [14]; Fujiwara et al. [10,11]; Kessler and Shamir [15]; Bhave and Sonak [3]; Eiger et al. [9]).

In recent years, heuristic-based techniques, as referred to stochastic optimization techniques, have been developed into powerful tools for optimization. Stochastic optimization techniques, for instances, genetic algorithms (GAs) and simulated annealing (SA), allow the resolution of design optimization problems formulated as nonlinear mixed integer problems. Advantages of heuristic optimization techniques over the conventional optimization techniques are their robustness, flexibility, general application, and capability of solving large combinatorial problems, but they do not guarantee the optimal solutions.

SA is a heuristic stochastic optimization method that has been suggested as a powerful optimization technique by which discrete or combinatorial problem can be solved. SA belongs to the global optimization method that provides near optimal solutions that can be accepted for most of the real-life problems. The basic idea behind SA is an analogy of physical annealing in solids. Its random search algorithm has the ability of escaping from local minima (minimization is assumed in the general discussion of the algorithms) by moving both uphill and downhill while conventional algorithms move only downhill. The uphill decision is made by the acceptance criterion incorporated with a probability function. The property of avoidance of the search process being trapped in local optima (using a descent strategy but allowing random ascent moves) overcomes, on many occasions, the major drawbacks of classical optimization methods. Application of SA requires little knowledge of the problem to be optimized other than an objective function.

SA was successfully applied to a wide range of problems in various fields such as economic, social, education, science and engineering. In the water resources field, SA has been little applied to optimize groundwater management problems (e.g., Dougherty and Marryott [8]; Marryott et al. [20]; Rizzo and Dougherty [27]; Cunha [6]), reservoir operation problems (e.g., Teegavarapu and Simonovic [30]; Mantawy, et al., [19]; Tospornsampan et al. [31], and other water resource related

works (e.g., Bardossy A. [2]; Kuo et al. [17]).

SA is quite a new technique for optimization of water distribution pipe network problems while applications of GAs were found from many works [e.g., Simpson et al. [29]; Dandy et al. [7]; Savic and Walters [28]; Montesinos et al. [22]]. Applications of SA to water distribution pipe network optimization were found from the work of Cunha and Sousa [5] and Loganathan et al. [18] who combined SA with MULTISTART search technique.

Applications of heuristic based techniques to water distribution network optimization overcome the complexity and uncertainty of conversion of continuous diameters into discrete diameters as found in the classical optimization techniques because discrete values of pipe diameters are used directly. Although the heuristic based techniques i.e. GAs, SA and Tabu search (Cunha and Riberiro [6]) were implemented to optimize the water distribution network problems already, it is found from those works that the solutions were limited to only the discrete diameter design in which only one diameter of pipe occupies an entire length of the link. Though realistic design requires single pipe solution, but if this is done, the design will not be optimal. At the optimal solution, each link will contain at most two segments (Alperovits and Shamir [1]). In this paper we propose a new procedure for the split-pipe design using SA to obtain the least cost design of water distribution network. In the proposed method, a set of pipe diameters is selected directly from a specified set of commercial pipe diameters. Its performance is illustrated through application to three well-know networks: the two-loop network, the Hanoi network, and the New York City network. To compare the solutions obtained in this study with those obtained for the discrete diameter design by other researchers; the solutions of the discrete diameter design are derived as well.

II. DESIGN OF WATER DISTRIBUTION PIPE NETWORK

Pipe network problems are usually solved by numerical methods using a computer since any analytical solution requires the use of many simultaneous equations. Three simple methods used to solve pipe network problems are the Hardy Cross method, the linear theory method, and the Newton Raphson method. The Hardy Cross method that involves a series of successive approximations and corrections to flows in individual pipes is the most popular procedure of analysis. Besides, the most well-known formulas that are used to evaluate the head loss in pipes are Darcy-Weisbach equation and Hazen-Williams equation. The Hazen-Williams equation that has been widely used in water supply engineering is written as:

$$h_f = \alpha L(Q/C)^{1.852} D^{-4.87} \quad (1)$$

where h_f is the head loss, α is a numerical conversion constant whose numerical value depends on the used units, L is the length of the pipe, Q is the discharge, C is a Hazen-Williams

coefficient of roughness and D is the pipe diameter.

The optimal design of a water distribution network for gravity system is to find the combination of commercial pipes with different sizes and lengths that provides the minimum cost for the given layout of network and a set of specified demands at the nodes while the pressure heads required at the nodes are also satisfied. Consider the network that composed of N nodes, t links, and m loops, the objective function of the least-cost design is to minimize the total cost of the system which is often assumed to be a cost function of pipe diameters and lengths as:

$$F = \min \sum_{i \in t} \sum_{j \in p(i)} C_{i,j} x_{i,j} \quad (2)$$

where F is the total cost of the network system, $C_{i,j}$ is the cost of the unit length of the j th pipe segment in link i which can be deterministic value or calculated by empirical formulas, $x_{i,j}$ is the length of the j th pipe segment in link i , and $p(i)$ is the set of all pipe segments in link i .

The objective function above is subject to the following constraints:

1. The flow entering a junction or node must equal the flow leaving it (the law of continuity):

$$\sum_{i \in in(k)} Q_i - \sum_{i \in out(k)} Q_i = q_k \quad \forall k \in N \quad (3)$$

where Q_i is the flow in link i , q_k is the demand at node k , $in(k)$ and $out(k)$ are the sets of all links connected into and out of node k , respectively. Note that $q_k > 0$ if k is a demand node, and $q_k < 0$ if k is a supply node.

2. The algebraic sum of the head losses (pressure drops) around any closed loop must be zero:

$$\sum_{i \in loop(n)} \pm hf_i = 0 \quad \forall n \in m \quad (4)$$

where hf_i is the head loss in link i which is calculated from (1), and $loop(n)$ is the set of all links in the n th loop

3. The head at a certain node in the network must satisfy a given minimum and maximum head limitations:

$$H_k^{\max} \geq H_k = H_s + \sum_{i \in path(s,k)} \pm hf_i \geq H_k^{\min} \quad \forall k \in N \quad (5)$$

where H_k^{\max} and H_k^{\min} are the maximum and minimum head allowed at node k , respectively, H_k is the head at node k , H_s is the head at any starting node s , and $path(s,k)$ is the path of links that connecting node s with node k .

4. Minimum and Maximum diameter requirements may be specified for certain pipes in the network:

$$D_{\max} \geq D_{i,j} \geq D_{\min} \quad \forall i, j \quad (6)$$

where D_{ij} is the diameter of the j th pipe segment in link i , D_{max} and D_{min} are the upper and lower bounds for diameter of pipes.

5. Minimum required discharge might be specified for certain pipes in the network:

$$Q_i \geq Q_i^{\min} \quad \forall i \quad (7)$$

where Q_i^{\min} is the minimum required flow rate along link i .

6. The total length of pipe segments in link i must be equal to the length of the link and each length must be nonnegative value:

$$\sum_{j \in p(i)} x_{i,j} = L_i \quad \forall i, j \quad (8)$$

$$L_i \geq x_{i,j} \geq 0 \quad \forall i, j \quad (9)$$

where L_i is the length of link i .

III. SIMULATED ANNEALING

SA is motivated by an analogy to physical annealing in solids, inspired from Monte Carlo methods in statistical mechanics. Kirkpatrick et al. [16] took the idea of annealing from Metropolis algorithm and applied to combinatorial optimisation problems (e.g., the travelling salesman problem, TSP).

The SA algorithm starts from randomly generating the initial configuration, which is analogous to the current solution that is composed of a set of decision variables of the problem, within feasible region at a high initial temperature value (T_0). Then, the new configuration is generated from the corresponding neighborhood of the current solution using a generation mechanism that implements a random rearrangement or perturbation of variables of the current configuration. One rearrangement is referred to as a transition. Acceptance of a transition from one state to another is depending on the Metropolis criterion given by $P(\Delta E) = \min [1, \exp(-\Delta E/T)]$ where $P(\Delta E)$ is probability of acceptance, $\Delta E = f(S_j) - f(S_i)$ is the difference of the objective function values of the new current configuration S_j and the current configuration S_i , and T is the current temperature, used to control the acceptance of modifications. If the new configuration is found to have a better fitness (evaluated by the objective function of the system) than its predecessor, then it is retained and the current configuration is discarded. If the new configuration is found to have a less fitness than its predecessor, it may be retained if the Boltzmann probability, $Pr = \exp(-\Delta E/T)$, is greater than the generated uniform random number r distributed in the interval (0,1). At the same temperature, the rearrangement must proceed long enough for sufficient number of transitions that allows the system to reach a steady state. Then the temperature is slowly decreased based on 'annealing schedule' and the process is repeated

successively until the stopping criterion is satisfied. The general procedure of SA applied in this study is illustrated in Fig. 1.

```

Generate an initial configuration  $S_i$ 
Select an initial temperature  $T_0$ 
Set temperature change counter,  $t=1$ 
 $T_t = T_0$ 
Repeat Until  $T_t = T_f$  or stopping criterion is met
  Set repetition counter  $L=0$ 
  Repeat Until  $L=L_t$ 
    Rearrangement by generating configuration  $S_j$ ,
    a neighbor of  $S_i$ 
    Calculate  $\Delta E = f(S_j) - f(S_i)$ , the improvement of
    objective function
    If  $\Delta E < 0$  then  $S_i = S_j$ 
    Else if  $\text{random}(0,1) < \exp(-\Delta E/T)$  then  $S_i = S_j$ 
     $L=L+1$ 
  End Repeat
   $t=t+1$ 
   $T_t = \alpha T_{t-1}$ 
End Repeat

```

Fig. 1 Simulated Annealing Algorithm

A. Annealing Scheduling

Annealing scheduling is the heart of SA. Avoidance of getting trapped in local minima is dependent on the annealing schedule that includes 1. the choice of an initial temperature, 2. the number of transitions at each temperature, and 3. the decrement rate of the temperature at each step as cooling proceeds (or cooling rate).

A temperature parameter is used to control the acceptance of modifications (rearrangements). The initial temperature value, T_0 , must be high enough to ensure a large number of acceptances at the initial stages. It is gradually decreased over time depending on the 'cooling rate' which is the coefficient used to decrease the temperature at the end of every temperature change counter. The cooling schedule is described as follows:

$$T_t = \alpha T_{t-1} \quad (10)$$

where T_t and T_{t-1} are the temperatures at the end and beginning of the cooling schedule at temperature change counter t and α is the 'cooling rate' which can range from 0 to 1. The value of α is accomplished in the ranges between 0.8 and 0.99 as suggested by Kirkpatrick et al. [16].

At each temperature, the configuration of the system is changed using a generation mechanism that implements a random perturbation of variables of current state. The total number of transitions at same temperature T constitutes a homogenous Markov chain of length given by the parameter L_t . L_t can be a constant value or varied during the annealing process. Setting parameters for SA is problem specific and it is best accomplished through trial and error.

B. Rearrangement of the system

Rearrangement or neighborhood generation is done by randomly changing the current configuration to a new one. Rearrangement can be performed in many different ways based on different types of problems. In the present work, the uniform mutation approach initiated in GA is adopted with some modification for rearrangement procedure. In this study each decision variable is allowed to change its value randomly within $\pm\sigma$ feasible ranges of its current value based on the probability of mutation, P_m . Initially, the search neighborhood, σ , may be large at high temperature and during the annealing process the search neighborhood may be decreased or maintained throughout the annealing process.

C. Termination of the algorithm

The stopping criterion is used to terminate the annealing process. In this study, the annealing process may be terminated when the fitness value is not improved over a specified number of successive iterations or when the final temperature reaches a specific level.

IV. OPTIMAL DESIGN OF WATER DISTRIBUTION NETWORK USING SIMULATED ANNEALING

From the previous studies of pipe network optimization, the design of pipe diameters can be classified into three categories. A continuous diameter design is an optimal set of pipe diameters that may take only continuous real value. A discrete diameter design is a set of pipe diameters that is selected from a specified set of commercial pipe sizes that span an entire length of the links. A split-pipe design may be derived from a continuous diameter design by decomposing a length of continuous diameter into two segment lengths of the two adjacent commercial diameters to create two pipes that span the link. Anyhow, the continuous diameter design is not practical because commercial pipe diameters are available in specified discrete diameters. Although attempts have been made to convert continuous diameters into one or two commercial discrete diameters in a segment, it is found that the conversion may not guarantee the optimality or even the feasibility of the solution.

In this paper a set of pipe diameters in the proposed split-pipe design is chosen directly from a specified set of commercial pipes. The complexity and uncertainty of conversion of continuous diameters into discrete diameters are eradicated because the optimality and feasibility of the solution can be determined directly.

The initial configuration or the initial solution of the water distribution network problem is a set of decision variables of the problem, which is the combination of commercial pipe segments in the network. In split-pipe design, a link may consist of one or two pipes of different diameters then the decision variables are composed of two commercial pipe diameters and a segment length in each link. Because two pipe segments are concatenated to form a link, the lengths of the

remaining segments can be derived by subtracting the variable of a segment length to the entire length of the link. The total number of decision variables for split-pipe design is triple to the number of links. In the discrete diameter design, only one pipe occupies an entire length in each link thus the decision variables are the commercial pipe diameters in each link whose number is equal to the total number of link. The decision variables of the segment pipe diameters are discrete values but the decision variables of the segment pipe lengths are continuous values whose required precision are decided at two decimal places in this study. Both variables of pipe segment diameters and pipe segment lengths are determined simultaneously throughout the algorithm.

Before implementing an optimization, assumption of an initial flow pattern of the network that satisfies the principle of continuity at each node as written in (3) is required. The SA algorithm starts from randomly generating an initial configuration (a set of decision variables) within the pre-specified range using pseudorandom generator at an initial temperature value (T_0). A correction to the assumed flows is computed successively for each loop in the network by Hardy Cross method based on the present configuration until the correction is reduced to an acceptable magnitude that makes the sum of head losses around any closed loop close to zero. After that the pressure head at each node is determined and the total cost of the network is computed subsequently in which the penalty costs are added if the constraints of pressure head and discharge are not satisfied. The new configuration is then generated using the rearrangement mechanism as described previously. The cost of the new configuration is determined again after the Hardy Cross procedure has been carried out. Acceptance of the new configuration is depending on the Metropolis criterion of acceptance as described above. The annealing process proceeds successively until the termination criterion is satisfied. Note that the same initial flow pattern is used at the beginning stage of Hardy Cross procedure. Fig. 2 shows the diagram of the SA algorithm applied to the least cost design of water distribution network described in this section.

V. ILLUSTRATED EXAMPLES

Performance of the developed SA based model for optimization of the least-cost design of water distribution network problem is evaluated through applications to the three well-known networks appearing in the literature, i.e., the two-loop network, the Hanoi network, and the New York city water supply network.

To compare the results with those obtained from the discrete diameter design and split-pipe design published in the literature, solutions of both designs are to be obtained. Because both designs in this work are derived from discrete diameter variables, the original discrete diameter design is called the single pipe design hereinafter. It is found from the literature that researchers did not use the same head-loss coefficient, α , in equation (1), therefore, different values of α

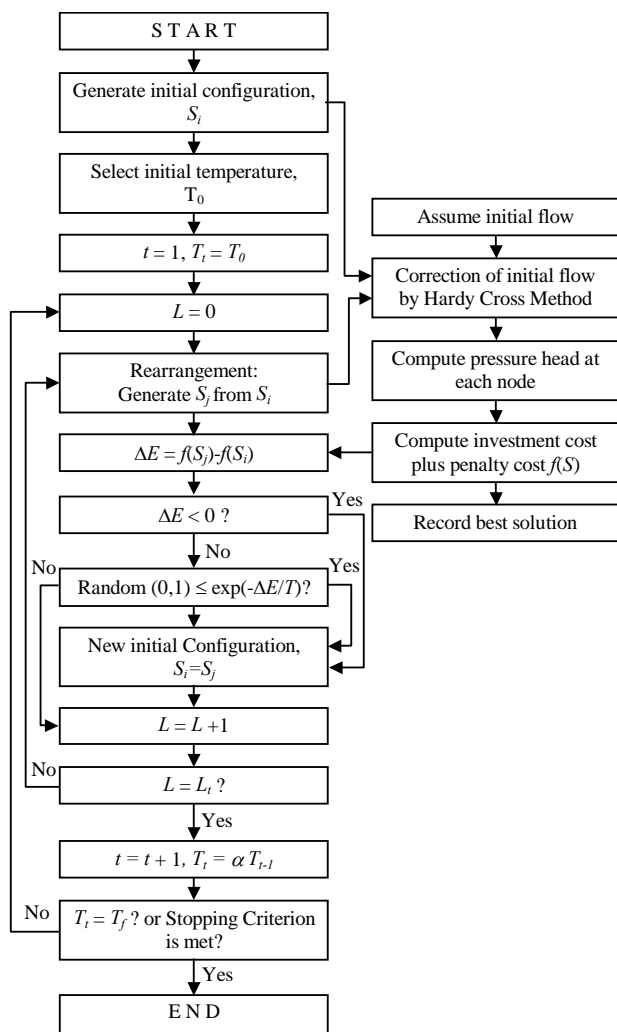

Fig. 2 Simulated Annealing for Water Distribution Network

are used in the present work in order to compare the results obtained in this study with those published in the literature. Following the work of Savic and Walters [28], the maximum and minimum values of α covering the range of published values are chosen for both designs which are equal to 10.5088 and 10.9031 respectively for Q in m^3/h , and D in centimeters ($= 8.439 \times 10^5$, and 8.710×10^5 respectively for Q in ft^3/s , and D in inches). Besides another values of α which are the same values as used in the original works of each problem are also used for split-pipe design. As results, five solutions are to be obtained from each problem.

A. Two-Loop Network

The two-loop network, as shown in Fig. 3, was first introduced by Alperovits and Sharmir [1]. The network consists of eight pipes, seven nodes, and two loops. The network is fed by gravity from a constant head reservoir at the first node. The system is to supply water to meet the required demand and to satisfy minimum pressure head at each node. Fourteen sizes of commercial pipe are available for the

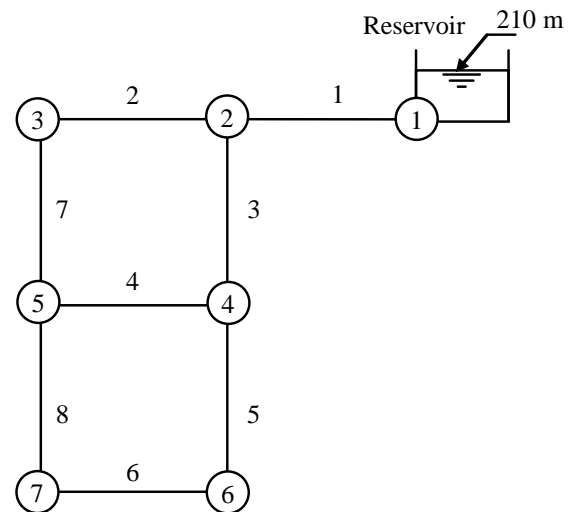

Fig. 3 Two-Loop Network

Authors	Fitting α^a	Cost (units)	Solution
Alperovits and Shamir (1997)	10.6792	479,525.00	Split-pipe
Goulter et al. (1986)	10.9031	435,015.00	Split-pipe
Kessler and Shamir (1989)	10.6792	417,500.00	Split-pipe
Eiger et al. (1994)	10.5088	402,352.06	Split-pipe
Loganathan et al. (1995)	10.6792	403,657.00	Split-pipe
Savic and Walters (1997)	10.5088	419,000.00	Single
Savic and Walters (1997)	10.9031	420,000.00	Single
Cunha and Sousa (1999)	10.5088	419,000.00	Single
Cunha and Ribeiro (2003)	10.5088	419,000.00	Single

^a For Q in m^3/h , and D in centimeters

network and each of them has its own unit cost. The Hazen-Williams coefficient is fixed at 130 for all pipes. The basic data necessary for the optimization are given in the paper of Alperovits and Sharmir [1].

The solutions for the two-loop network taken from the literature are given in Table 1. Note that solutions of the continuous diameter design are not chosen, as they are not practicable in reality. SA performed for several runs with different seed numbers for the pseudorandom generator using different sets of parameters. For water distribution network problem, choices of parameters are really hard tasks. Appropriate parameter values are very difficult to define. The effect of changing values of each parameter on the performance of SA cannot be distinguished clearly. Moreover, the objective function values obtained from each solution are not converted into the same direction unlike those obtained from solutions of reservoir operation (Tospornsampan et al. [31]). However, the values of parameters T_0 , α , σ , and L_t that seem to work well for the problem are ranged from 10-100, 0.9-0.95, 0.1-0.25%, and 500-1000 respectively. The best solutions obtained by SA in this study are shown in Table 2. The optimal pressure heads corresponding to those solutions are shown in Table 3. Though the convergence cannot be derived, SA produced very satisfactory results. Many good solutions that are better than or comparable to those in the

TABLE II
SOLUTIONS OF TWO-LOOP NETWORK FROM SIMULATED ANNEALING

Link	SA1 (Single) $\alpha^a=10.5088$		SA2 (Single) $\alpha^a=10.9031$		SA3 (Split-pipe) $\alpha^a=10.5088$		SA4 (Split-pipe) $\alpha^a=10.6792$		SA5 (Split-pipe) $\alpha^a=10.9031$	
	D (in.)	L (m)	D (in.)	L (m)	D (in.)	L (m)	D (in.)	L (m)	D (in.)	L (m)
1	18	1000	18	1000	18	1000	20	33.43	18	1000
2	10	1000	10	1000	10	827.58	10	801.78	10	745.74
3	16	1000	16	1000	16	172.42	12	198.22	12	254.26
4	4	1000	4	1000	16	1000	16	1000	16	1000
5	16	1000	16	1000	1	1000	1	1000	1	1000
6	16	1000	16	1000	16	613.34	14	338.99	16	807.56
7	10	1000	10	1000	14	386.66	16	661.01	14	192.44
8	10	1000	10	1000	8	21.17	10	989.38	10	1000
					10	978.83	8	10.62		
					10	891.64	10	901.26	10	914.61
					8	108.36	8	98.74	8	85.39
					1	1000	1	1000	1	1000
Cost (units)	419,000.00		419,000.00		400,337.97		403,751.22		408,035.00	

^a For Q in m^3/h , and D in centimeters

TABLE III
OPTIMAL PRESSURE HEADS FOR TWO-LOOP NETWORK

Link	Min. Head Req. (m)	SA1 (Single)	SA2 (Single)	SA3 (Split-pipe)	SA4 (Split-pipe)	SA5 (Split-pipe)
		$\alpha^a=10.5088$ Head (m)	$\alpha^a=10.9031$ Head (m)	$\alpha^a=10.5088$ Head (m)	$\alpha^a=10.6792$ Head (m)	$\alpha^a=10.9031$ Head (m)
2	30	53.35	53.10	53.35	53.33	53.10
3	30	30.78	30.05	30.02	30.01	30.01
4	30	43.63	43.20	44.03	43.94	43.62
5	30	34.22	33.26	30.01	30.00	30.01
6	30	30.67	30.14	30.02	30.00	30.02
7	30	30.86	30.14	30.00	30.00	30.02

^a For Q in m^3/h , and D in centimeters

literature are obtained. The best solutions of the single pipe design obtained from the present study using both lower limit and the upper limit of α values are same as those obtained from Savic and Walters [28] and Cunha and Sousa [5,6] which are derived from using the lower limit of $\alpha = 10.5088$. Though the solutions of both α values are same but the pressure head corresponding to them are different. The solution obtained using the upper limit of $\alpha = 10.9031$ is superior to those obtained by other researchers. This could be due to the marginal differences of coefficient value used in equation (1). The least cost solution of the split-pipe design obtained in this study using the lower limit of $\alpha = 10.5088$ is less expensive than the best one published in the literature of Eiger et al. [1994] that satisfies the minimum head constraint at the same α value. The solution obtained using $\alpha = 10.6792$ is slightly more expensive than that of Loganathan et al. [18] (only 0.02% difference). The least cost solution thus found is the lowest-cost solution for the two-loop network to date.

B. Hanoi Network

The water distribution trunk network in Hanoi, Vietnam, first introduced by Fujiwara and Khang [11] is shown in Fig. 4. The network consists of 34 pipes, 32 nodes, and 3 loops. The problem is similar to the two-loop network that is fed by gravity from a single fixed head source and is to satisfy

demands at required pressures. In this problem six sizes of commercial pipe are available and the cost of each pipe i with diameter D_i and length L_i is calculated from $C_i = 1.1 \times D_i^{1.5} \times L_i$, where cost is in dollars, diameter is in meters, and length is in meters. The Hazen-Williams coefficient is fixed at 130 for all pipes. The data necessary for the optimization can be found in the work of Fujiwara and Khang [11].

It is found from published solutions in the literature that the solutions of this problem are sometimes less realistic because some segments of split-pipes have too short lengths compared with their link lengths. To avoid such problem, a constraint of the minimum length of pipe segment length that must be at least or more than 5% of its link length is imposed to this network.

In this problem, good solutions are rather difficult to be derived compared with the two-loop network problem. The same sets of parameters were used but higher numbers of iterations were required to obtain good solutions because the number of variables is higher and the network is more complex. Table 4 summarizes solutions of Hanoi network found from the literature. The best solutions obtained by SA are shown in Table 5 and the optimal pressure heads corresponding to those solutions are shown in Table 6. The least cost solutions of the single pipe design obtained using both lower limit and upper limit of α are superior to other corresponding solutions published in the literature. The least cost solution of split-pipe design obtained in this study using the lower limit of $\alpha = 10.5088$ is cheaper than that of Eiger et al. [9] which is the best solution published in the literature that satisfies the minimum head constraint at the same α value. In addition, the best solution obtained is more realistic compared to that of Eiger et al. [9]. As pointed out by Savic and Walters [28], a segment length of pipe 11 and 27 of the solution of Eiger et al. [9] are only 0.09% and 2.43% of their total pipe lengths while in the best solution the shortest segment length

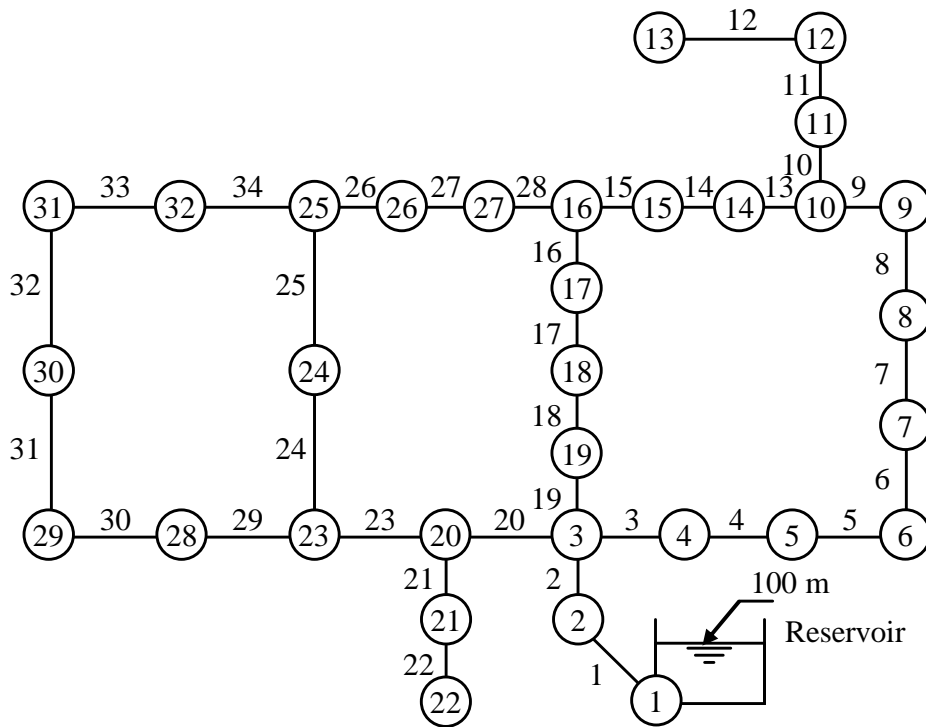

Fig. 3 Hanoi Network

TABLE IV
PREVIOUS SOLUTIONS OF HANOI NETWORK

Authors	Fitting α^a	Cost (\$ million)	Solution
Fujiwara et al. (1990, 1991)	10.5088	6.320	Split-pipe
Sonak and Bhave (1993)	10.5088	6.046	Split-pipe
Eiger et al. (1994)	10.5088	6.027	Split-pipe
Savic and Walters (1997)	10.5088	6.073	Single
Savic and Walters (1997)	10.9031	6.195	Single
Cunha and Sousa (1999)	10.5088	6.056	Single
Cunha and Ribeiro (2003)	10.5088	6.056	Single

^a For Q in m^3/h , and D in centimeters

is more than 11% of its total pipe lengths. In fact, SA produced many good solutions with different combinations of pipe segments, the designer may choose the solutions that are practicable though their costs may be little more expensive than the best but less realistic ones. The solutions thus obtained show that SA has produced significant improvement in solutions and that the least cost solution found in this study is the lowest-cost solution yet presented in the literature for the Hanoi network.

C. New York City Water Supply Network

The data of the New York City water supply tunnels is taken from Quindry et al. [25], Fujiwara and Khang [11] and Dandy et al. [7]. The configuration of the network, as shown in Fig. 5, consists of 21 pipes, 20 nodes, and 2 loops. The work is to construct additional gravity flow tunnels parallel to the existing system to satisfy the increased demands at the required pressures. Sixteen sizes of diameters (including none pipe) are available and the cost of each pipe i with diameter D_i and length L_i is calculated from $C_i = 1.1 \times D_i^{1.24} \times L_i$ in

which cost is in dollars, diameter is in inches, and length is in feet. Although the cost function is used to calculate the investment cost for this problem, the unit cost of each pipe has been transformed into discrete values and is given in Dandy et al. [7]. In the present work, the discrete values of unit costs are used. The Hazen-Williams coefficient for this problem is assumed at 100 for all existing and new pipes.

Previous solutions of the New York City water supply network obtained from the literature are shown in Table 7. The lowest cost design was found in the work of Fujiwara and Khang [11]. Unfortunately their solution was proved to be clearly infeasible (Loganathan et al. [18]; Dandy et al. [7]; Savic and Walters [28]). Therefore the feasible least cost solution of this problem is that of Savic and Walters [28], which is derived from the single pipe design.

For this problem, the same sets of parameters were used as well but good solutions could be obtained easier than that of the Hanoi network. The best solutions obtained from SA are shown in Table 8. The optimal pressure heads corresponding to those solutions are shown in Table 9. The best solutions of the single pipe design obtained in the present study are as same as those obtained from Savic and Walters [28] and Cunha and Sousa [5]. The least cost of split-pipe design obtained from SA using the lower limit of $\alpha = 843900$ is less than the least cost solutions of Savic and Walters [28] and Cunha and Ribeiro [6] which were derived from the single pipe design. The solution of split-pipe design obtained from SA using $\alpha = 851500$ is very close to that obtained from Loganathan et al. [18] but the solution of Loganathan et al. [18] is found to be slightly infeasible but it is only marginal.

TABLE V
SOLUTIONS OF HANOI NETWORK FROM SIMULATED ANNEALING

Link	SA 1 (Single) $\alpha^a=10.5088$		SA 2 (Single) $\alpha^a=10.9031$		SA 3 (Split-pipe) $\alpha^a=10.5088$		SA 4 (Split-pipe) $\alpha^a=10.6823$		SA 5 (Split-pipe) $\alpha^a=10.9031$	
	D(in.)	L (m)	D(in.)	L (m)	D(in.)	L (m)	D(in.)	L (m)	D(in.)	L (m)
1	40	100	40	100	40	100	40	100	40	100
2	40	1350	40	1350	40	1350	40	1350	40	1350
3	40	900	40	900	40	900	40	900	40	900
4	40	1150	40	1150	40	1150	40	1150	40	1150
5	40	1450	40	1450	40	1450	40	1450	40	1450
6	40	450	40	450	40	450	40	450	40	450
7	40	850	40	850	40	850	40	850	40	850
8	40	850	40	850	30	565.95	40	850	30	139.08
9	30	800	40	800	40	284.05	40	800	40	710.92
10	30	950	30	950	30	800	40	800	30	800
11	24	1200	30	1200	30	950	30	824.13	30	950
12	24	3500	24	3500	24	395.66	24	125.87	24	1200
13	16	800	20	800	16	804.34	20	524.86	16	800
14	12	500	16	500	12	3500	16	3500	12	500
15	12	550	16	550	12	564.02	12	800	16	800
16	12	2730	12	2730	12	235.98	16	500	12	500
17	20	1750	16	1750	12	500	12	328.49	12	550
18	24	800	24	800	12	550	16	221.51	16	2730
19	24	400	20	400	16	2730	12	2730	16	2730
20	40	2200	40	2200	20	1750	16	1750	20	1750
21	20	1500	20	1500	24	800	24	292.60	24	800
22	12	500	12	500	20	800	20	507.40	20	800
23	40	2650	40	2650	24	400	20	147.90	24	400
24	30	1230	30	1230	24	400	24	252.10	24	400
25	30	1300	30	1300	40	2200	40	2200	40	2200
26	20	850	20	850	20	1500	20	1191.36	20	812.24
27	12	300	16	300	16	1500	16	308.64	16	687.76
28	12	750	12	750	16	500	12	500	16	500
29	16	1500	16	1500	12	444.17	12	300	12	300
30	12	2000	12	2000	40	2650	40	2650	40	2650
31	12	1600	12	1600	30	1230	30	1230	30	1230
32	12	150	16	150	30	1300	30	1300	30	1300
33	16	860	20	860	20	850	20	850	20	850
34	24	950	24	950	20	725.48	20	850	20	850
					16	124.52	12	300	12	300
					12	300	12	300	12	300
					12	750	12	750	12	750
					16	1500	16	1500	16	1500
					12	2000	12	2000	12	2000
					12	1600	12	1600	12	1600
					16	150	16	92.86	16	89.09
					20	860	20	57.14	20	60.91
					16	860	20	393.85	16	860
					24	950	16	466.15	16	860
					20	449.76	24	950	24	950
Cost (\$ Million)	6.026		6.188		6.023		6.111		6.169	

^a For Q in m^3/h , and D in centimeters

TABLE VI
OPTIMAL PRESSURE HEADS FOR HANOI NETWORK

Link	Min. Head Req. (m)	SA 1	SA 2	SA 3 (Split-pipe)	SA 4 (Split-pipe)	SA 5 (Split-pipe)
		$\alpha^a=10.5088$	$\alpha^a=10.9031$	$\alpha^a=10.5088$	$\alpha^a=10.6823$	$\alpha^a=10.9031$
		Head (m)	Head (m)	Head (m)	Head (m)	Head (m)
1	100	100.00	100.00	100.00	100.00	100.00
2	30	97.17	97.08	97.18	97.12	97.08
3	30	62.00	60.82	62.24	61.37	60.82
4	30	57.23	55.92	58.06	56.54	56.39
5	30	51.32	49.85	52.89	50.55	50.90
6	30	45.07	43.45	47.50	44.22	45.17
7	30	43.61	41.94	46.26	42.74	43.85
8	30	41.85	40.14	44.85	40.96	42.33
9	30	40.44	38.70	41.52	39.54	40.54
10	30	39.40	37.64	38.34	38.49	37.08
11	30	37.85	36.05	36.80	36.50	35.48
12	30	34.43	34.86	34.16	34.32	34.30
13	30	30.24	30.56	30.02	30.06	30.00
14	30	35.49	33.69	30.33	34.59	31.66
15	30	33.44	31.64	30.01	32.59	30.64
16	30	30.36	30.91	30.82	30.57	30.86
17	30	30.51	32.58	40.30	31.79	39.17
18	30	44.29	48.97	51.45	47.56	50.00
19	30	55.90	54.18	58.55	57.28	57.12
20	30	50.89	49.57	51.30	50.20	49.58
21	30	41.58	40.02	34.70	36.91	31.42
22	30	36.42	34.74	30.04	31.67	30.13
23	30	44.73	43.39	45.26	44.04	43.40
24	30	39.03	37.66	39.75	38.35	37.94
25	30	35.34	33.99	36.20	34.69	34.49
26	30	31.44	30.39	31.47	31.00	30.90
27	30	30.15	30.18	30.42	30.03	30.09
28	30	39.12	38.00	39.50	38.53	36.53
29	30	30.21	30.01	30.01	30.07	30.01
30	30	30.47	30.51	30.15	30.45	30.00
31	30	30.75	30.82	30.42	30.67	30.48
32	30	33.20	31.73	32.72	32.48	32.48

^a For Q in m^3/h , and D in centimeters

The least cost solution found in this study is the lowest-cost solution yet published in the literature for the New York City water network.

VI. CONCLUDING REMARKS

The heuristic-based SA has been developed and applied to optimize the least cost design of water distribution networks. The new procedure of the split-pipe design that obtained from the discrete diameter design using SA has been presented. The model was applied to the three well-known networks appearing in the literature: the two-loop network, the Hanoi network, and the New York City water network. Both solutions of the single pipe design and the split-pipe design were obtained using different values of head loss coefficients. They are compared with those published in the literature.

SA provides very satisfactory solutions. The least cost solutions of all test networks obtained in this study are the lowest-cost solutions yet presented in the literature. It is proved from the present work that the least cost design of water distribution network is obtained from the split-pipe design because the solutions of the split-pipe design always produce lower costs than those obtained from the single pipe design when the same value of α is used. Though some solutions of the split-pipe design are less realistic, the designer can choose an appropriate one that is practicable as SA provides many good solutions with different combinations of

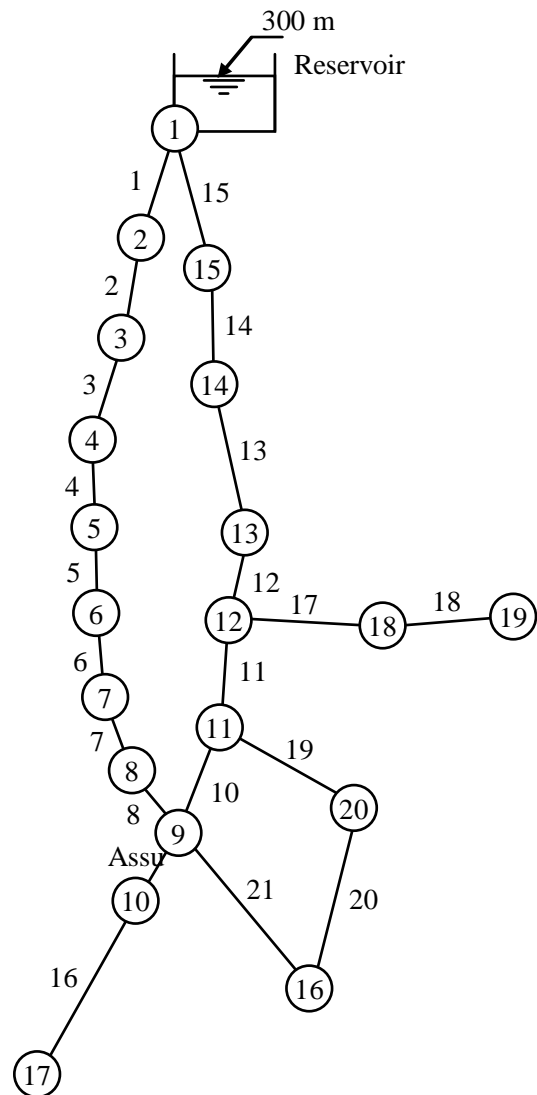

Fig. 5 New York City Water Network

TABLE VII
PREVIOUS SOLUTIONS OF NEW YORK CITY WATER SUPPLY NETWORK

Authors	Fitting α^a	Cost (\$ million)	Solution
Morgan and Goulter (1985)	851500	38.9	Split-pipe
Morgan and Goulter (1985)	851500	39.2	Single
Fujiwara et al. (1990)	None	36.6	Split-pipe
Loganathan et al. (1995)	851500 ^b	38.04	Split-pipe
Dandy et al. (1996)	851500	38.8	Single
Savic and Walters (1997)	843900	37.13	Single
Savic and Walters (1997)	871000	40.42	Single
Montesinos et al. (1999)	851500	38.8	Single
Cunha and Ribeiro (2003)	843900	37.13	Single

^a For Q in ft^3/s , and D in inches

^b Slightly infeasible

pipe sizes and lengths.

Results obtained from these applications prove that SA is flexible and has ability to effectively handle an optimization of a complex water distribution network in which the continuous diameter design, the single pipe design and the split-pipe design can be formulated. Significant advantage of

TABLE VIII
SOLUTIONS OF NEW YORK CITY WATER SUPPLY NETWORK FROM SIMULATED ANNEALING

Link	SA 1 (Single) $\alpha^a=843900$		SA 2 (Single) $\alpha^a=871000$		SA 3 (Split-pipe) $\alpha^a=843900$		SA 4 (Split-pipe) $\alpha^a=851500$		SA 5 (Split-pipe) $\alpha^a=871000$	
	D (in.)	L (ft)	D (in.)	L (ft)	D (in.)	L (ft)	D (in.)	L (ft)	D (in.)	L (ft)
1	0	0	0	11600	0	0	0	0	0	0
2	0	0	0	19800	0	0	0	0	0	0
3	0	0	0	7300	0	0	0	0	0	0
4	0	0	0	8300	0	0	0	0	0	0
5	0	0	0	8600	0	0	0	0	0	0
6	0	0	0	19100	0	0	0	0	0	0
7	108	9600	0	9600	108	5479.60	120	1940.63	0	0
8	0	0	0	12500	96	4120.40	132	7659.37	0	0
9	0	0	0	9600	0	0	0	0	0	0
10	0	0	0	11200	0	0	0	0	0	0
11	0	0	0	14500	0	0	0	0	0	0
12	0	0	0	12200	0	0	0	0	0	0
13	0	0	0	24100	0	0	0	0	0	0
14	0	0	0	21100	0	0	0	0	0	0
15	0	0	144	15500	0	0	0	0	132	5492.72
16	96	26400	84	26400	96	26400	96	26400	144	10007.28
17	96	31200	96	31200	96	31200	108	265.90	96	31200
18	84	24000	84	24000	72	764.96	96	30934.10	84	22641.40
19	72	14400	72	14400	84	23235.04	84	24000	72	1358.60
20	0	0	0	0	72	14400	72	14247.69	72	14400
21	72	26400	72	26400	84	152.31	84	0	72	721.01
					60	423.26	72	26400	60	25678.99
					72	25976.74				
Cost (\$ million)	37.13		40.42		36.87		38.05		40.04	

^a For Q in ft^3/s , and D in inches

SA over the conventional optimization methods is their handling of complex, highly nonlinear problems that accurately reflect the real world. Though SA does not guarantee the global optimum solution, many good solutions are obtained which are practically useful in reality.

Performance of SA depends on the type of the applied problem. Though the algorithm is very easy to implement, its performance is largely dependent on fine-tuning of the parameters and neighborhood generation mechanism. The difficulty in choice of optimal parameters is significant problems and time-consuming. More robust parameter set and effective generation mechanism should be considered to improve the performance of the algorithm for the problem of water distribution network. Since SA is quite a new technique for optimization of the water distribution network problem, it can be considered as an alternative tool for this area of research. Further applications of SA to the layout and operation of water distribution networks are expected as well.

REFERENCES

- [1] E. Alperovits and U. Shamir, Design of optimal water distribution systems, *Water Resources Research*, vol. 13, no. 6, pp. 885-900, 1997.
- [2] A. Bárdossy, Generating precipitation time series using simulated annealing, *Water Resources Research*, vol. 34, no. 7, pp. 1737-1744, 1998.
- [3] P.R. Bhawe and V.V. Sonak, A critical study of the linear programming gradient method for optimal design of water supply networks, *Water Resources Research*, vol. 28, no. 6, pp. 1577-1584, 1992.
- [4] M.D.C. Cunha, On Solving Aquifer Management Problems with Simulated Annealing Algorithms, *Water Resources Management*, vol. 13, pp. 153-169, 1999.
- [5] M.D.C. Cunha and J. Sousa, Water Distribution Network Design Optimization: Simulated Annealing Approach, *Journal of Water Resources Planning and Management ASCE*, vol. 125, no. 4, pp. 215-221, 1999.
- [6] M.D.C. Cunha and L. Ribeiro, Tabu search algorithms for water network optimization, *European Journal of Operational Research*, vol. 157, pp. 746-758, 2004.

TABLE IX
OPTIMAL PRESSURE HEADS FOR NEW YORK CITY WATER SUPPLY NETWORK

Link	Min. Head Req. (ft)	SA 1 (Single)	SA 2 (Single)	SA 3 (Split-pipe)	SA 4 (Split-pipe)	SA 5 (Split-pipe)
		$\alpha^2=843900$ Head (ft)	$\alpha^3=871000$ Head (ft)	$\alpha^3=843900$ Head (ft)	$\alpha^3=851500$ Head (ft)	$\alpha^2=871000$ Head (ft)
1	300	300.00	300.00	300.00	300.00	300.00
2	255	294.34	294.59	294.35	294.24	294.58
3	255	286.47	287.15	286.50	286.24	287.11
4	255	284.16	285.00	284.21	283.89	284.95
5	255	282.13	283.13	282.18	281.81	283.07
6	255	280.55	281.70	280.61	280.21	281.64
7	255	278.08	279.54	278.15	277.67	279.46
8	255	276.52	276.45	276.43	276.56	276.35
9	255	273.76	274.32	273.70	273.71	274.20
10	255	273.73	274.29	273.67	273.68	274.17
11	255	273.86	274.48	273.80	273.81	274.35
12	255	275.15	276.00	275.10	275.09	275.86
13	255	278.12	279.31	278.07	278.06	279.17
14	255	285.58	287.56	285.55	285.54	287.40
15	255	293.34	296.09	293.33	293.32	295.91
16	260	260.16	260.30	260.00	260.00	260.00
17	272.8	272.86	272.92	272.80	272.80	272.80
18	255	261.30	261.70	261.24	261.15	261.56
19	255	255.21	255.41	255.00	255.00	255.00
20	255	260.82	261.00	260.71	260.68	260.79

^a For Q in ft^3/s , and D in inches

- [7] G.C. Dandy, A.R. Simpson, and L.J. Murphy, An improved genetic algorithm for pipe network optimization, *Water Resources Research*, vol. 32, no. 2, pp. 449-458, 1996.
- [8] D.E. Dougherty and B.A. Marryott, Optimal groundwater management, 1. simulated annealing, *Water Resources Research*, vol. 27, no. 10, pp. 2493-2508, 1991.
- [9] G. Eiger, U. Shamir, and A.B. Tal, Optimal design of water distribution networks, *Water Resources Research*, vol. 30, no. 9, pp. 2637-2646, 1994.
- [10] O. Fujiwara, B. Jenchaimahakoon, and N.C.P. Edirisinghe, A modified linear programming gradient method for optimal design of looped water distribution networks, *Water Resources Research*, vol. 23, no. 6, pp. 977-982, 1987.
- [11] O. Fujiwara and D.B. Khang, A two-phase decomposition method for optimal design of looped water distribution networks, *Water Resources Research*, vol. 26, no. 4, pp. 539-549, 1990.
- [12] O. Fujiwara and D.B. Khang, Correction to "A two-phase decomposition method for optimal design of looped water distribution networks" by Okitsugu Fujiwara and Do Ba Khang, *Water Resources Research*, vol. 27, no. 5, pp. 985-986, 1991.
- [13] D.E. Goldberg, *Genetic Algorithms in Search, Optimization, and Machine Learning*, 2nd edn. Addison-Wesley, Reading, Mass, 1989.
- [14] I.C. Goulter, B.M. Lussier, and D.R. Morgan, Implications of head loss path choice in the optimization of water distribution networks, *Water Resources Research*, vol. 22, no. 5, pp. 819-822, 1986.
- [15] A. Kessler and U. Shamir, Analysis of the linear programming gradient method for optimal design of water supply networks, *Water Resources Research*, vol. 25, no. 7, pp. 1469-1480, 1989.
- [16] S. Kirkpatrick, C.D. Gelatt, and M.P. Vecchi, Optimization by Simulated Annealing, *Science*, vol. 220, no. 4598, pp. 671-680, 1983.
- [17] S.F. Kuo, C.W. Liu, and G.P. Markley, Application of the Simulated Annealing Method to Agricultural Water Resources Management, *J. agric. Engng. Res.*, vol. 80, no. 1, pp. 109-124, 2001.
- [18] G.V. Loganathan, J.J. Greene, and T.J. Ahn, Design heuristic for globally minimum cost water-distribution systems, *Journal of Water Resources Planning and Management ASCE*, vol. 121, no. 2, pp. 182-192, 1995.
- [19] A.H. Mantawy, S.A. Soliman, and M.E. El-Hawary, The long-term hydro-scheduling problem – a new algorithm, *Electric Power Systems Research*, vol. 64, pp. 67-72, 2003.
- [20] R.A. Marryott, D.E. Dougherty, and R.T. Stollar, Optimal Groundwater Management; 2. Application of Simulated Annealing to a Field-Scale Contamination Site, *Water Resources Research*, vol. 29, no. 4, pp. 847-860, 1993.
- [21] Z. Michalewicz, *Genetic Algorithms + Data Structures = Evolutionary Programs*, 3rd edn. Springer-Verlag, New York, 1996.
- [22] P. Montesinos, A.G. Guzman, and J.L. Ayuso, Water distribution network optimization using a modified genetic algorithm, *Water Resources Research*, vol. 35, no. 11, pp. 3467-3473, 1999.
- [23] D.R. Morgan and I.D. Goulter, Optimal urban water distribution design, *Water Resources Research*, vol. 21, no. 5, pp. 642-652, 1985.
- [24] S.G. Ponnambalam and M.M. Reddy, A GA-SA Multiobjective Hybrid Search Algorithm for Integrating Lot Sizing and Sequencing in Flow-Line Scheduling, *Int. J. Adv. Manuf. Technol.*, vol. 21, pp. 126-137, 2003.
- [25] G.E. Quindry, E.D. Brill, and J.C. Liebman, Optimization of looped water distribution systems, *Journal of the Environmental Engineering Division ASCE*, vol. 107, no. 4, pp. 665-679, 1981.
- [26] G.E. Quindry, E.D. Brill, J.C. Liebman, and A.R. Robinson, Comment on 'Design of optimal water distribution systems' by E. Alperovits and U. Shamir, *Water Resources Research*, vol.15, no. 6, pp. 1651-1654, 1979.
- [27] D.M. Rizzo and D.E. Dougherty, Design Optimization for Multiple Management Period Groundwater Remediation, *Water Resources Research*, vol. 32, no. 8, pp. 2549-2561, 1996.
- [28] D.A. Savić and G.A. Walters, Genetic algorithms for least-cost design of water distribution networks, *Journal of Water Resources Planning and Management ASCE*, vol. 123, no. 2, pp. 67-77, 1997.
- [29] A.R. Simpson, G.C. Dandy, and L.J. Murphy, Genetic algorithms compared to other techniques for pipe optimization, *Journal of Water Resources Planning and Management ASCE*, vol. 120, no. 4, pp. 423-443, 1994.
- [30] R.S.V. Teegavarapu and S.P. Simonovic, Optimal Operation of Reservoir System Using Simulated Annealing, *Water Resources Management*, vol. 16, pp. 401-428, 2002.
- [31] J. Tospornsampan, I. Kita, M. Ishii, Y. Kitamura, Optimization of multiple reservoir system using simulated annealing: a case study in the Mae Klong system, Thailand, *Paddy and Water Environment*, Vol. 3, No. 3, pp.137-147, September, 2005.
- [32] K.V.K. Varma, S. Narasimhan, and M. Bhallamudi, Optimal design of water distribution systems using an NLP method, *Journal of Environmental Engineering ASCE*, vol. 123, no. 4, pp. 381-388, 1997.