

Mathematical Approach towards Fault Detection and Isolation of Linear Dynamical Systems

V.Manikandan and N.Devarajan

Abstract—The main objective of this work is to provide a fault detection and isolation based on Markov parameters for residual generation and a neural network for fault classification. The diagnostic approach is accomplished in two steps: In step 1, the system is identified using a series of input / output variables through an identification algorithm. In step 2, the fault is diagnosed comparing the Markov parameters of faulty and non faulty systems. The Artificial Neural Network is trained using predetermined faulty conditions serves to classify the unknown fault. In step 1, the identification is done by first formulating a Hankel matrix out of Input/ output variables and then decomposing the matrix via singular value decomposition technique. For identifying the system online sliding window approach is adopted wherein an open slit slides over a subset of 'n' input/output variables. The faults are introduced at arbitrary instances and the identification is carried out in online. Fault residues are extracted making a comparison of the first five Markov parameters of faulty and non faulty systems. The proposed diagnostic approach is illustrated on benchmark problems with encouraging results.

Keywords—Artificial neural network, Fault Diagnosis, Identification, Markov parameters.

I. INTRODUCTION

FAULT diagnosis of dynamical systems is an active area of research in the control community over the past two decades. Industrial systems in real working environment suffer parameter deviation with the passage of time. Hence it becomes mandatory to detect these parameter variations to make the system fool proof and robust. Many control approaches utilize the system parameters for affecting the control law – one notable approach is the famous state feedback control, If parameters deviate from the nominal values, the control which depends in these parameters also varies and the closed loop performance of the system degrades. In all parameter based control approaches, the parameter identification becomes the first step

[1],[2],[40],[41],[42]. With the passage of time, either the parameters vary slowly or in case of fault these parameters make a rapid transition from their nominal values. Hence continuous supervision of these parameters from the measurement of available system variables becomes absolutely essential to ensure a sturdy performance of the system in closed loop. Fault diagnosis is very often considered as fault detection and isolation ,abbreviated as FDI in the literature [3]-[4]. The detection and isolation of faults in engineering systems is of great practical significance. The early detection of the occurrence of faults is critical in avoiding product deterioration, performance degradation, major damage to the machinery itself and damage to human health or loss of lives. The quick and correct diagnosis of the faulty component then facilitates the making of appropriate and optimal decisions on emergency and corrective actions, and on repairs. These aspects can minimize downtime, increase the safety of the plant operations and reduce manufacturing costs. The traditional approaches to fault detection and diagnosis involve the limit checking of some variables or the application of redundant sensors . More advanced methods are data-driven process monitoring methods[5],[6], most heavily used in many chemicals and manufacturing industries. Principal component analysis and partial least squares are multivariate statistical methods that generalize the univariate control charts that been applied for decades. Fisher discriminant analysis and canonical variate analysis have also been for diagnosis purposes. Other methods rely on analytical redundancy[4],[7],[8],the comparison of the actual plant behaviour to that expected on the basis of a mathematical model. These models take their origins from chemical process control, where the traditional material and energy balance calculations evolved into systematic data reconciliation and the detection of gross errors[9]. The latter approach includes methods that are more deterministically framed such as parity relations from input –output model [3] and observers [4],[10] and those formulated are more statistical basis (Kalman filter[11]) and parameter estimation [12]. When analytical models are not readily available, a correctly trained neural network can be used as a non linear dynamic model of the system[8],[13],[14]. Sometimes, further insight is required as to the explicit behavior of the model involved and it is here that

Manuscript received on January 2007.This work was part of the research work fulfillment.

V.Manikandan is with Electrical & Electronics Engineering Department, Coimbatore Institute of Technology, India. (Ph: +919865678896; e-mail: mani_sr2005@hotmail.com.)

N.Devarajan is with Electrical and Electronics Engineering Department, Government College of Technology, Coimbatore, India. (Ph: +919443245163;e-mail:profdevarajan@yahoo.com).

fuzzy[15]-[17] and even neuro fuzzy methods[18]-[20] come into their own in fault diagnosis applications. Other authors have used evolutionary programming tools to design observers[8],[21] and neural networks[22]-[24]. The work on fault diagnosis Artificial Intelligence community was initially focused on the expert system or knowledge-based approaches[25], where heuristics are applied to explicitly associate symptoms with fault hypothesis. The shortcomings of a pure expert system approach led to the development of model-based approaches based on qualitative models in form of qualitative differential equations, signed diagraphs, qualitative functional and structural models, etc., [5],[8],[26]. Most of the jobs that use knowledge-based methods work with models of system in the presence of the faults. This implies the need to construct a different model to each possible fault. Most of the time, it is not possible to obtain a model of the system with a particular fault, because the system could be damaged by that fault, or because that might be dangerous to provoke the faults or because not all possible faults can be provoked. In model-based fault diagnosis can be defined as the determination of a system's faults by comparing the available system measurements with a priori information represented by the system's mathematical model, through the generation of residual quantities and their analysis [27]. A complete model-based fault detection and isolation system must include at least two modules: The residual generator where the plant behaviours checked. Residuals are quantities that measure the inconsistencies between the actual plant variables and the mathematical model. They are ideally zero, but they become nonzero if the actual system differs from the model; this may be caused by faults, disturbances, noise and modeling errors. For a dynamic system, the residual generator is dynamic as well. It may be constructed by means of a number of different techniques. An adequate design of the residual generator allows fault to be isolated, and therefore, classification of the residual vector into a specific fault case. An important performance characteristic of the residual generator is the fault sensitivity of the residuals that is, the ability of the generator to detect faults of a reasonably small size. The three main ways to generate residuals are observers [4],[10],[11], parity equations [3] and parameter estimation [12]. The linear theory of these approaches is well developed and their relationship is also well understood. The equivalence of the various methods has been studied by several authors [28],[29]. For nonlinear systems, the fault diagnosis problem has traditionally been approached in two steps. Firstly, the model is linearized at an operating point, and then techniques are applied to generate residuals [30],[31]. To deal with systems with high nonlinearity and wide operation range, the fault diagnosis problem has to be tackled directly using nonlinear techniques [32]-[36]

The decision module must evaluate the reliability of every residual, as well as the decision risk. Faulty conditions must cause certain residual changes, depending on the fault case. A large variety of tests may be applied [37]. The appropriate statistical test is chosen according to the properties of the residual. However, residual behavior is often less reliable than

desired due to the presence of modeling errors, disturbances and noise. In order to avoid false alarms, the thresholds of fault detection tests are frequently selected high enough. This implies conservative criteria, and often, therefore, a delay in fault diagnosis. The model uncertainty increases the problem of threshold selection and even adaptive thresholds have been proposed [38]. The parity equations approach checks the consistency of the mathematical equations of the systems with the measurements. In the early development of fault diagnosis, the parity relations approach was applied to static or parallel redundancy schemes that may be obtained directly from measurements of from analytical relations. The parity relation concept was using the temporal redundancy relations of the dynamic system. The parity equations can also be constructed using a z-transformed input-output model or discrete transfer matrix representation [39], [3].

The main goal of the fault diagnosis methods are reliability and robustness, because they allow these methods to be implemented in industrial systems. The uncertainty of system models, the presence of noise and the stochastic behavior of several variables make it hard to reach these goals. To tackle these kinds of problems, in this paper a Markov parameter based approach is proposed for the diagnosis of faults in linear dynamical systems. The approach basically consists of identifying a system by forming a Hankel matrix from i/p and o/p pairs. Using the sliding window approach the system is identified online. Parameter deviation are introduced arbitrarily in between and the faulty system is identified. The residue for the fault classification is obtained by comparing the Markov parameters of faulty and non faulty systems. The ANN trained through the BPN algorithm for known fault conditions serves as a classifier to classify the fault. The complete fault diagnosis module encompasses a fault preprocessor and fault classifier. The objective of the fault processor is to identify the system and generate Markov parameters of the faulty /non-faulty system. The fault classifier makes comparison of the Markov parameters of faulty system with that of the nominal system and does the fault classification. In section II a brief mathematical analysis of the proposed technique is dealt. Section III addresses the proposed diagnosis approach. In section IV, the algorithm for the proposed method is given. The proposed approach is illustrated on a standard benchmark problem and the simulation results are summarized in section V. Finally, in Section VI, we conclude by giving some comments on the application of the technique.

II. PROPOSED FAULT DIAGNOSIS APPROACH

The work carried out to deals with the identification of parameter deviations in a system using Markov parameter and the schematic is shown in Figure 1.

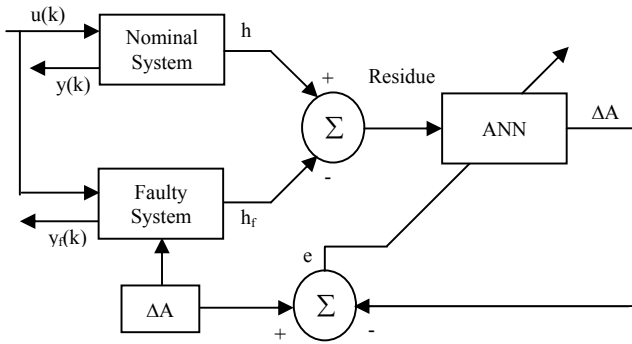

Fig. 1 Proposed fault diagnosis approach

The steps involved in fault diagnosis are outlined below:

- A. System identification
- B. Computation of Markov parameters
- C. Extraction of fault residues
- D. ANN based classification.

In this work the black box identification process is considered for the following reasons.

- a) More flexibility
- b) More independence in choosing the order the system

The identification process constructs a matrix from the input/output data in a specialized format. This matrix is known as Hankel matrix. The Hankel matrix is decomposed using singular value decomposition (SVD) and the system is identified using recursive least square method. This method proposed by [41] is employed in our work for fault diagnosis. The comfortness in choosing this method lies in identifying a system for limited number of input/output data. The algorithm is simple, accurate and works in discrete domain. The algorithm is flexible in the sense if it works for random inputs and pseudo binary random sequence (PRBS). As the algorithm works for limited number of input/output data the diagnosis becomes very fast in nature. Random inputs can be very easily generated and there are simple state machine and shift registers that generate pseudo binary sequence. Faults are introduced arbitrarily. When faults are introduced, the output signals due to random input sequence vary considerably and the Hankel matrix elements also change. The identified system is to faulty system and the Markov parameters differ when compared to that of the healthy system. The Markov parameter is employed in this work for extracting the fault residue. Markov parameters are those parameters, which are identical for two systems producing similar input/output combinations. Markov parameters are the unique combination of input/output and system matrices. Though two systems are dissimilar physically Markov parameters identifies a new system with respect to input/output parlance. In the proposed diagnostic approach, the Simulation Before Test (SBT) analysis is carried out initially with known different system faults. The identification process is done and the Markov parameters are extracted. Similar procedure is carried out for

single as well as multiple faults. Faults are so introduced that system doesn't become unstable. This restriction gives bounds for fault magnitudes. The fault residue is computed by finding the difference between the Markov parameters of the healthy and faulty system. ANN with suitable pre-training does the fault classification. The benchmark problems are chosen of different types. Practical system is considered to make the work industry friendly. Standard second system is taken into consideration. The main advantage in the proposed technique is the scheme also works satisfactorily for stochastic systems. As the diagnosis scheme takes lesser time on line identification with proper atomization ensures satisfactory system performance for a considerable period of time by switching the system from the 'normal' to 'diagnosis' mode. In this work, the first 5 Markov parameters for extracting the residues are taken to demonstrate the illustrations. The ANN classifier structure has 5 neuron in the input layer 10 neuron in the hidden layer and one neuron in the output layer. The ANN is trained using BPN algorithm and does accurate classification of faults based on the difference between the Markov parameter of the healthy and faulty system. The main assumption incorporated into the work is that the system is completely observable. The limitation of the scheme is that the fault diagnosis is done only for system faults. With slighter modification the proposed detection algorithm could be extended for actuator fault as well. This is not a serious limitation in the sense that if the state space description is in controllable canonical form, the problem is solved automatically. In this system, the proposed approach for the diagnosis of system faults is dealt with. The system is initially subjected to known fault condition and the fault signature is extracted by comparing the Markov parameters of the nominal system and the faulty system. Similar set of fault signatures are extracted for various known fault conditions and are used for training an artificial neural network for classification purpose. This pre-trained ANN does the classification of unknown fault that enters into the system.

A. System identification

Identification aims at finding a mathematical model from the measurement record of inputs and outputs of the system. A state space model is the obvious choice for a mathematical representation because of its widespread use in system theory and control. The main step in the identification procedure consists in the singular value decomposition of a block Hankel matrix. As it will turn out only the left singular basis is required, both the computational load and the noise sensitivity are considerably reduced. The discrete system is excited with 'm' number of random inputs and the corresponding output variables are measured. The problem now is to identify the system matrices A, B, C, D of the unknown system from the given input/output measurements, The deterministic algorithm consists of forming Hankel matrix H constructed from the I/O sequences $u[k], u[k+1] \dots$ and $y[k], y[k+1] \dots$. As it is obvious that only the observable part of the system can be identified from observed I/O data, it can be assumed that the system is completely observable, thus omitting the unobservable part at the very outset. The Hankel matrix thus formulated is decomposed using singular value decomposition

and system matrices A_i, B_i, C_i, D_i are then identified straightaway by solving the set of linear equations in least square sense. The system identification scheme is given in Figure 2.

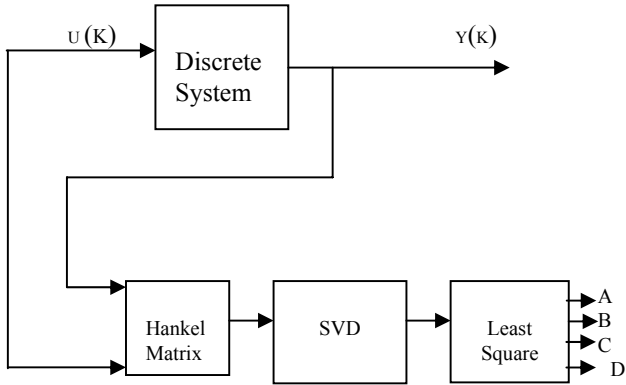

Fig. 2 System Identification

B. Computing Markov parameters and extracting fault residues

The impulse response terms $CA^{n-1}B$ for $n \geq 0$ (n - order of the system) are known as Markov parameters. Hence, the Markov parameters are known as impulse response coefficients. The Markov parameters h_0, h_1, h_2, \dots can be constructed from the given impulse responses of the system matrices A, B and C . In general, Markov parameters are unaffected by system transformation like eigen values. The advantage of the Markov parameters is that it gives unbiased estimated of the system matrices with the state sequence approach in a straightforward way.

The fault residue is the difference between the Markov parameters of the healthy and faulty system. The system is initially subjected to known fault condition and the fault residue is extracted by comparing the Markov parameters of the nominal system and the faulty system. Similar set of fault signatures are extracted for various known fault conditions and are used for training an artificial neural network for classification purpose. The neural network is trained using back propagation algorithm in which the weights and bias of the ANN are automatically updated based on the difference between the actual output of the network and the target. The network is trained for a number of known faulty conditions. The introduced faults are so chosen in such a way that the system doesn't loose its stability under fault. Once the network is trained it does fault classification for unknown fault conditions. This pre-trained ANN does the classification of unknown fault that enters into the system. The schematic is shown in Figure 3.

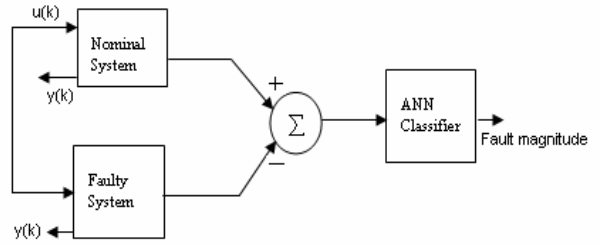

Fig. 3 Extracting fault residues

C. Pattern classifier

Since the pattern classifier test pattern for the systems as 5 inputs and 1 output, the ANN pattern classifier should have 5 neurons in the input layer and 1 neuron in the output layer. The number of hidden layer and its neurons are randomly varied till satisfactory results are obtained. It is determined that one hidden layer with 10 neurons is enough for the classifier to perform the task of classifying the faults. Therefore the ANN structure boils down to 5:10:1. The classifier for the proposed method is shown in Figure 4.

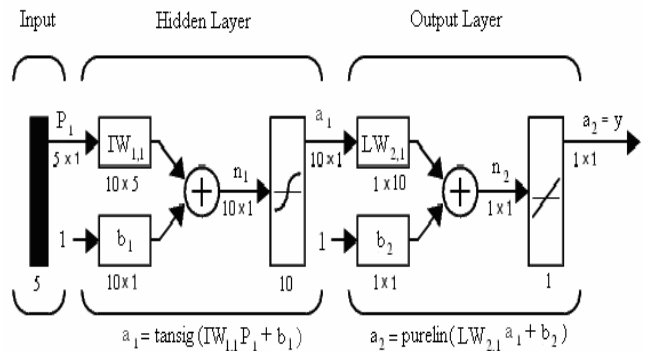

Fig. 4 Pattern classifier

In back propagation neural network, each input is weighted with an appropriate 'w'. The sum of the weighted inputs and the bias forms the input to the transfer function 'f'. Neurons may use any differentiable transfer function 'f' to generate their output. The transfer function used for hidden layer in the classifier designed is 'tansig' bipolar sigmoid transfer function and for output layer is 'purelin' transfer function. The linear output layer lets the network produce values outside the range -1 to +1. On the other hand, if the outputs of a network are need to be constrained (such as between -1 and +1), then the output layer should use a sigmoid transfer function (such as tansig). Similarly if the outputs of a network are need to be constrained (such as between 0 and 1), then the output layer should use a sigmoid transfer function (such as logsig). Generally the training function is 'trainlm'. This updates weight and bias values according to Levenberg-Marquardt optimization. The adaptation learning function 'learngd' is the gradient descent weight and bias learning function. The

performance function is ‘mse’ known as mean squared error as it measures the network’s performance according to mean squared errors.

D. Mathematical Analysis of the Proposed Technique

1. Formation of Hankel matrix

Consider a Linear Non faulty discrete system,

$$X(K + 1) = AX(k) + Bu(k) \tag{1}$$

$$Y(k) = CX(k) + DU(k)$$

Where $A \in R^{n \times n}$ is the system matrix

$B \in R^{n \times m}$ is the input matrix

$C \in R^{r \times n}$ is the output matrix

$D \in R^{r \times m}$ is the direct transmission matrix

The discrete system is excited with ‘m’ number of random inputs and the corresponding output variables are measured. The problem now is to identify the system matrices A, B, C, D of the unknown system from the given input/ output measurements. The deterministic algorithm consists of forming Hankel matrix H constructed from the I/O sequences $u[k], u[k+1] \dots$ and $y[k], y[k+1] \dots$. As it is obvious that only the observable part of the system can be identified from observed I/O data, it can be assumed that the system is completely observable., thus omitting the unobservable part at the very outset. The system matrices A, B, C, D are identified by making use of the SVD of H. The Hankel matrix H is constructed by concatenating two matrices

$$H_1 \in R^{(k+i-1) \times (k+j-1)} \text{ and } H_2 \in R^{(k+i) \times (k+i+j)} \tag{2}$$

where

$$H_1 = \begin{bmatrix} u[k] & u[k+1] & \dots & u[k+j-1] \\ y[k] & y[k+1] & \dots & y[k+j-1] \\ u[k+1] & u[k+2] & \dots & u[k+j] \\ y[k+1] & y[k+2] & \dots & y[k+j] \\ \vdots & \vdots & \ddots & \vdots \\ u[k+i-1] & u[k+i] & \dots & u[k+j+i-2] \\ y[k+i-1] & y[k+i] & \dots & y[k+j+i-2] \end{bmatrix} \tag{3}$$

and

$$H_2 = \begin{bmatrix} u[k+i] & u[k+i+1] & \dots & u[k+i+j-1] \\ y[k+i] & y[k+i+1] & \dots & y[k+i+j-1] \\ u[k+i+1] & u[k+i+2] & \dots & u[k+i+j] \\ y[k+i+1] & y[k+i+2] & \dots & y[k+i+j] \\ \vdots & \vdots & \ddots & \vdots \\ u[k+2i-1] & u[k+2i] & \dots & u[k+j+2i-2] \\ y[k+2i-1] & y[k+2i] & \dots & y[k+j+2i-2] \end{bmatrix} \tag{4}$$

where the integers i and j are sufficiently large and $j \gg \max(m_i, r_i)$. where m, n are the number of inputs and outputs, where $i \geq n$, where n is the order of system. In this paper i and j are selected such that the Hankel matrix is a square matrix and the number of inputs is equal to the and is number of outputs (T) given by

$$T = j + 2i - 1 \tag{5}$$

2. Singular value decomposition

The Hankel matrix thus formulated is decomposed using singular value decomposition and the following result is obtained.

$$H = USV^T = \begin{bmatrix} U_{11} & U_{12} \\ U_{21} & U_{22} \end{bmatrix} \begin{bmatrix} S_{11} & 0 \\ 0 & 0 \end{bmatrix} V^T \tag{6}$$

where

$$U_{11} \in R^{(mi+ri) \times (2mi+n)} \tag{7}$$

$$U_{12} \in R^{(mi+ri) \times (2ri-n)} \tag{8}$$

$$S_{11} \in R^{(2mi+n) \times (2mi+n)} \tag{9}$$

In the next step, we again perform the singular value decomposition of $U_{12}^T U_{11} S_{11}$ and the following result is obtained

$$U_{12}^T * U_{11} * S_{11} = (U_q \ U_q^\perp) \begin{bmatrix} S_q & 0 \\ 0 & 0 \end{bmatrix} \begin{bmatrix} V_q^T \\ V_q^{\perp T} \end{bmatrix} \tag{10}$$

where $V_q \in R^{n \times (2ri-n)}$

3. Identification

The system matrices A_i, B_i, C_i, D_i are then identified by solving the following set of linear equations in least square sense.

$$\begin{bmatrix} U_q^T * U_{12}^T * U(m+r+1:(i+1)(m-1),:) * S \\ U(m+r+1:m+r+1:(i+1),:) * S \end{bmatrix} = \begin{bmatrix} A_i & B_i \\ C_i & D_i \end{bmatrix} \begin{bmatrix} U_q^T * U_{12}^T * U(1:m+ri, :) * S \\ U(m+r+1:m+ri+m) * S \end{bmatrix} \tag{11}$$

where the subscript ‘i’ indicates the identified matrix. In the identification parlance usually the Markov parameters of the original system and those of the identified system are compared as an index for identification.

4. Computing Markov parameters

The impulse response of the state model shown in equation (12) is easily found by direct calculation. Let $x(0) = 0$. Then

$$\left. \begin{aligned} h(0) &= C x(0) + B + D = D \\ x(1) &= A x(0) + B \delta(0) = B \\ h(1) &= C x(1) = CB \\ x(2) &= A x(1) + B \delta(1) = AB \\ h(2) &= CAB \\ x(3) &= A x(2) + B \delta(2) = A^2 B \\ h(3) &= C A^2 B \\ \vdots & \\ \vdots & \\ h(n) &= C A^{n-1} B, \quad n > 0 \end{aligned} \right\} \tag{12}$$

Thus the impulse response of the state-space model can be summarized as

$$h(n) = \begin{cases} D, & n = 0 \\ C A^{n-1} B, & n > 0 \end{cases} \tag{13}$$

The impulse response terms $CA^{n-1}B$ for $n > 0$ are known as Markov parameters. Thus Markov parameters are known as impulse response coefficients. In general, eigen values are unaffected by a similarity transformation. Similarly

Markov parameters are also unaffected by system transformation. If Markov parameters of original and identified system are same, then the actual system and the identified system are same. In this manner the Markov parameters serves as an index for the identification of algorithm. For the online identification of the system sliding window approach is incorporated .In this approach a new input is processed for each instant where in one old input is discarded and the new input/output pair enters into the system identification algorithm.

5. *Mathematical Analysis for the faulty system*

Consider the Linear faulty system
 $X_f(K+1) = (A+\Delta A)X_f(K) + B X(K)$
 $Y_f(K)=C_f(K)+D_fX(K)$ (14)

where $\Delta A \in R^{n \times n}$ is the system fault

The faulty system is identified using the algorithm discussed in the previous section the identified faulty system matrices are A_f, B_f, C_f and D_f respectively. The Markov parameters for the identified faulty system is computed as follows

$M_f(n)=C(A+\Delta A)^{n-1}B, n=1,2,3, \dots$ (15)

6. *Residue Generation*

The Markov parameters of the faulty system is compared with those of the nominal system and the fault residues are extracted

$R = M(n) - M_f(N).$

$=CA^{n-1}B-C(A+\Delta A)^{n-1}.B, n=1,2,3, \dots$ (16)

III. PROPOSED DIAGNOSIS ALGORITHM

- Step-1: For the given reference system , find the fault range ($\Delta_1 - \Delta_2$) that can be added to the system matrix elements to keep the system in stable.
- Step-2: For the ‘ Δ ’ value varying from ‘ Δ_1 to Δ_2 ’ follow the steps 3 to 10.
- Step-3: Once the ‘ Δ ’ value is added to the system matrix elements, the new system matrix is formed. Then the new system is given for system identification algorithm given in steps 4-8.
- Step-4: For the first instant, the inputs are generated randomly and processed to the new reference system and the corresponding outputs are determined and the input data is saved for next iteration. In next iteration, this saved input data is taken and last input is discarded and a new input is generated randomly and input data along with new input is saved for next iteration and processed to the reference system to determine new output data. The new input data along with the new output data is sent for system identification analysis.
- Step-5: Form Hankel matrix H from input and output data. The total number of inputs (T) should be selected such that hankel matrix formulated should be a square matrix using (2), (3), (4) and (5).
- Step-6: Calculate U and S from SVD of H using (9)

- Step-7: Calculate SVD of $U_{12}^T * U_{11} * S_{11}$ using (10)
- Step 8: Identify the system parameters using (11)
- Step-9: Find the first 5 Markov parameters of the identified system.
 $h(n) = CA^{n-1}B$ for $n = 1$ to 5
- Step-10: The ‘ Δ ’ values along with its corresponding first 5 Markov parameters are sent for training
- Step-11: Once the neural network is trained, it can be used for simulation. Now the online approach takes place. For every instant a new system matrix is sent for system identification. Follow steps 4 - 8 for identifying the new system.
- Step-12: The first 5 Markov parameters of the new identified system are calculated and sent to the neural network for simulation resulting in value of the ‘ Δ ’ added to the system matrix with respect to reference system.
- Step-13: The neural network results in identifying the instant at which the reference system’s matrix is fluctuated.

IV. ILLUSTRATION

The proposed fault diagnosis approach is applied to a linear system and the results are submitted in this section .The inputs and outputs of the system with and without faults are identified on line using sliding slit approach. When faults are introduced at random instances Markov parameters of the system vary from its nominal value. This variation is employed to classifying the fault using ANN classifiers.

Consider the discrete time system given [43] by the following equation

$$\begin{bmatrix} x_1(k+1) \\ x_2(k+1) \end{bmatrix} = \begin{bmatrix} -0.2 & 0.3 \\ 1 & 0 \end{bmatrix} \begin{bmatrix} x_1(k) \\ x_2(k) \end{bmatrix} + \begin{bmatrix} 1 \\ 0 \end{bmatrix} u(k)$$
 (17)

$$y = \begin{bmatrix} 1 & -1 \end{bmatrix} \begin{bmatrix} x_1(k) \\ x_2(k) \end{bmatrix}$$

The eigen value of the nominal system are 0.4568,-0.6568. The eigen value lie within the unit circle and hence the system is stable. For identifying the system the parameters i and j are chosen as 4 and 16 respectively .Hence the total number of the input/output pair becomes $T= 16+2*4-1=23$; $n=2, m=r=1$ for the system. The inputs are chosen as random sequence and the corresponding outputs are generated. One such combination is shown below.

Input
 $U = \begin{bmatrix} 0.95 & 0.23 & 0.61 & 0.49 & 0.89 & 0.76 & 0.46 & 0.02 \\ 0.82 & 0.44 & 0.62 & 0.79 & 0.92 & 0.74 & 0.18 & 0.41 \\ 0.94 & 0.92 & 0.41 & 0.89 & 0.06 & 0.35 & 0.81 \end{bmatrix}$ (18)

Corresponding Output
 $Y = \begin{bmatrix} 0.00 & 0.95 & -0.91 & 0.84 & -0.56 & 0.77 & -0.45 & 0.02 \\ -0.58 & 0.92 & -0.73 & 0.59 & -0.16 & 0.34 & -0.30 & -0.40 \\ 0.22 & 0.37 & -0.03 & -0.39 & 0.55 & -1.06 & 0.67 \end{bmatrix}$ (19)

Then, Hankel matrix is identified from the input and output is as follows

$$H = \begin{bmatrix} 0.950.230.610.490.890.760.460.020.820.440.620.790.920.740.180.41 \\ 0 \quad 0.950.910.840.560.770.450.020.580.920.730.590.160.340.300.40 \\ 0.230.610.490.890.760.460.020.820.440.620.790.920.740.180.410.94 \\ 0.950.910.840.560.770.450.020.580.920.730.590.160.340.300.400.22 \\ 0.610.490.890.760.460.020.820.440.620.790.920.740.180.410.940.92 \\ -0.910.840.560.770.450.020.580.920.730.590.160.340.300.400.220.37 \\ 0.490.890.760.460.020.820.440.620.790.920.740.180.410.940.920.41 \\ 0.840.560.770.450.020.580.920.730.590.160.340.300.400.220.370.03 \\ 0.890.760.460.020.820.440.620.790.920.740.180.410.940.920.410.89 \\ -0.560.770.450.020.580.920.730.590.160.340.300.400.220.370.030.39 \\ 0.760.460.020.820.440.620.790.920.740.180.410.940.920.410.890.06 \\ 0.770.450.020.580.920.730.590.160.340.300.400.220.370.030.390.55 \\ 0.460.020.820.440.620.790.920.740.180.410.940.920.410.890.060.35 \\ -0.450.020.580.920.730.590.160.340.300.400.220.370.030.390.551.06 \\ 0.020.820.440.620.790.920.740.180.410.940.920.410.890.060.350.81 \\ 0.020.580.920.730.590.160.340.300.400.220.370.030.390.551.060.67 \end{bmatrix} \quad (20)$$

The Hankel matrix is decomposed using SVD and the matrices U_{11} , U_{12} and S_{11} are calculated

$$U_{11} = \begin{bmatrix} -0.30 & -0.04 & 0.11 & 0.19 & -0.01 & -0.32 & -0.37 & 0.31 & 0.24 & 0.33 \\ -0.01 & 0.23 & -0.34 & 0.07 & -0.39 & -0.49 & -0.07 & 0.10 & 0.37 & -0.50 \\ -0.32 & 0.10 & -0.12 & -0.14 & 0.21 & 0.18 & -0.34 & 0.38 & -0.03 & 0.02 \\ -0.03 & -0.26 & 0.35 & 0.21 & 0.33 & 0.10 & -0.35 & 0.06 & -0.07 & -0.70 \\ -0.36 & -0.05 & 0.05 & -0.22 & -0.28 & 0.17 & 0.14 & 0.39 & -0.13 & -0.04 \\ -0.02 & 0.26 & -0.40 & -0.35 & 0.03 & 0.33 & 0.08 & 0.09 & -0.14 & -0.32 \\ -0.33 & 0.17 & 0.10 & 0.32 & -0.06 & -0.05 & 0.32 & 0.18 & -0.29 & -0.04 \\ -0.04 & -0.28 & 0.36 & 0.05 & -0.40 & -0.04 & 0.36 & 0.00 & -0.09 & -0.20 \end{bmatrix} \quad (21)$$

$$U_{12} = \begin{bmatrix} -0.34 & 0.15 & 0.12 & -0.23 & 0.31 & 0.24 \\ 0.10 & -0.04 & -0.04 & 0.07 & -0.09 & -0.07 \\ 0.14 & 0.45 & -0.12 & 0.26 & -0.32 & -0.32 \\ -0.01 & -0.15 & 0.02 & -0.05 & 0.07 & 0.07 \\ 0.27 & -0.30 & 0.52 & -0.20 & -0.16 & 0.14 \\ -0.41 & 0.18 & -0.04 & -0.17 & 0.36 & 0.21 \\ -0.33 & -0.20 & -0.28 & 0.45 & -0.17 & 0.26 \\ -0.11 & 0.63 & 0.03 & -0.09 & 0.05 & -0.16 \end{bmatrix} \quad (22)$$

$$S_{11} = \begin{bmatrix} 5.51 & 0 & 0 & 0 & 0 & 0 & 0 & 0 & 0 & 0 \\ 0 & 4.14 & 0 & 0 & 0 & 0 & 0 & 0 & 0 & 0 \\ 0 & 0 & 2.85 & 0 & 0 & 0 & 0 & 0 & 0 & 0 \\ 0 & 0 & 0 & 2.19 & 0 & 0 & 0 & 0 & 0 & 0 \\ 0 & 0 & 0 & 0 & 2.00 & 0 & 0 & 0 & 0 & 0 \\ 0 & 0 & 0 & 0 & 0 & 1.34 & 0 & 0 & 0 & 0 \\ 0 & 0 & 0 & 0 & 0 & 0 & 1.25 & 0 & 0 & 0 \\ 0 & 0 & 0 & 0 & 0 & 0 & 0 & 0.95 & 0 & 0 \\ 0 & 0 & 0 & 0 & 0 & 0 & 0 & 0 & 0.89 & 0 \\ 0 & 0 & 0 & 0 & 0 & 0 & 0 & 0 & 0 & 0.50 \end{bmatrix} \quad (23)$$

The singular value decomposition of $(U_{12}^T * U_{11} * S_{11})$, to exact U_q and S_q as follows

$$U_q = \begin{bmatrix} -0.49 & -0.03 & -0.15 & -0.62 & 0.34 & 0.49 \\ -0.10 & -0.44 & 0.83 & 0.11 & -0.06 & 0.30 \\ -0.06 & -0.80 & -0.47 & 0 & -0.38 & 0.02 \\ 0.60 & 0.18 & 0.04 & -0.44 & -0.49 & 0.41 \\ -0.41 & 0.33 & -0.16 & 0.51 & -0.43 & 0.50 \\ 0.47 & -0.16 & -0.22 & 0.39 & 0.56 & 0.50 \end{bmatrix} \quad (24)$$

$$S_q = \begin{bmatrix} 1.33 & 0 \\ 0 & 1.11 \end{bmatrix} \quad (25)$$

The Identified System is as follows

$$\begin{bmatrix} x_1(k+1) \\ x_2(k+1) \end{bmatrix} = \begin{bmatrix} 0.1364 & 0.2361 \\ 1.7062 & -0.3364 \end{bmatrix} \begin{bmatrix} x_1(k) \\ x_2(k) \end{bmatrix} + \begin{bmatrix} -0.5182 \\ 0.5022 \end{bmatrix} u \quad (26)$$

$$y = [-0.3442 \quad 1.6263] \begin{bmatrix} x_1(k) \\ x_2(k) \end{bmatrix} + [2.4349e-016] u$$

The identified system eigen values are 0.4568 and -0.6568, which is same as that of the original system (Equation17). Comparing the eigen values of the original system and identified system is not enough to validate the system identification process, since the eigen values are obtained only by considering the system matrix (A). Therefore identified system is validated by comparing the Markov parameters of the original and identified system. In this work, the first 20 Markov parameters are used for the comparison purpose, is shown in Table 1.

TABLE I
FIRST 10 MARKOV PARAMETERS OF ORIGINAL AND IDENTIFIED SYSTEM

First 20 Markov parameters	Markov parameters of the actual system (h)	Markov parameters of the identified system (h _i)
1	1.0002	1.0002
2	-1.2003	-1.2003
3	0.5402	0.54027
4	-0.468	-0.46827
5	0.2556	0.25581
6	-0.19152	-0.1917
7	0.11498	0.11512
8	-0.080453	-0.080556
9	0.050586	0.050661
10	-0.034253	-0.034309
11	0.022026	0.022066
12	-0.14681	-0.01471
13	0.0095441	0.0095647
14	-0.0063132	-0.0063278
15	0.0041259	0.0041362
16	-0.0027191	-0.0027264
17	0.0017816	0.0017866
18	-0.0011721	-0.0011756
19	0.00076889	0.00077133
20	-0.00050539	-0.00050709

Now, the faulty matrix ΔA of the unknown magnitude is introduced at arbitrary time instants. For this study, the faults are introduced in the system matrix (A) at two different intervals is shown in Equation (27).

$$\Delta A = \left\{ \begin{array}{l} \text{delta} = 0,0 \leq t \leq 30\text{sec} \\ \text{delta} = 3,30 \leq t \leq 35\text{sec} \\ \text{delta} = 3.3,35 \leq t \leq 40\text{sec} \\ \text{delta} = 0,40 \leq t \leq c \end{array} \right\} \quad (27)$$

The first 5 Markov parameters of faulty system is extracted and compared with the Markov parameters of the

nominal system and the fault residues are extracted as shown in the following figure 5 and 6 respectively

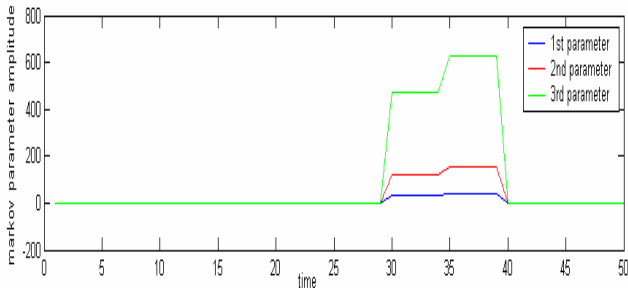

Fig. 5 Variation of 1st, 2nd and 3rd Markov parameters with respect to time

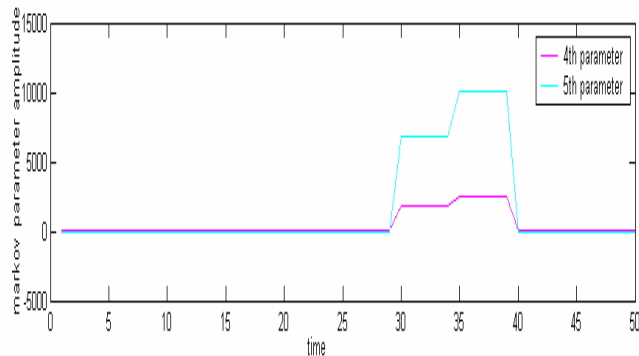

Fig. 6 Variation of 4th and 5th Markov parameters with respect to time

The network is trained to perform the pattern classification. The training process requires a set of trained data of network inputs (input1 to input5=first 1 to 5 Markov parameters) and network output (target1=delta). During training the weights and biases of the network are iteratively adjusted to minimize the network performance function. The training data generated is used to train the neural network. The network is trained for 1000 epochs. The training goal is varied to get maximum convergence. The performance plot is shown in Figure 7.

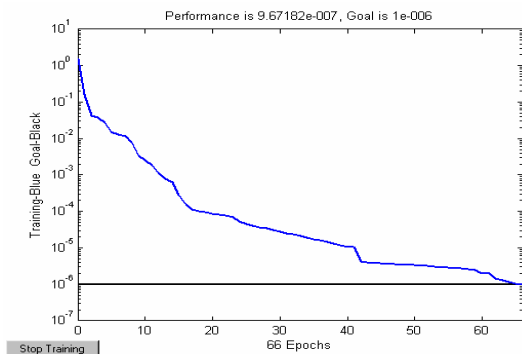

Fig. 7 Performance plot of the classifier

The pretrained neural network does the fault classification and gives the fault magnitude of 3 between 30 to 35 samples and 3.3 between 35 to 40 and zero other wise. Hence the network classifies the fault quite satisfactorily The corresponding plot is shown in figure 8.

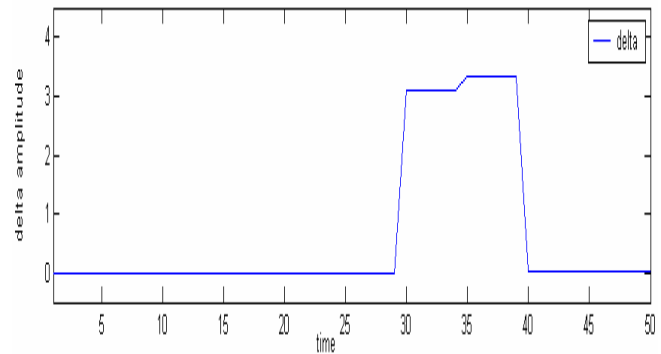

Fig. 8 ANN output for change in delta values corresponding to time

V. DISCUSSION

In this work, a new approach to fault diagnosis using Markov parameters has been presented. The significant advantage of the new approach is that it is given unbiased estimates of the parameter variations in a straightforward way. As a result, any adaptive effects due to ill conditioning of the input signals are minimized. Our results indicate that this approach of identifying fault in system matrix is effective in terms of its ability to detect the exact magnitude of change in parameter of the system matrix and to some relatively low dimensional state space model. Interestingly, the task is accomplished without having to compute explicitly the system dependent interaction matrix itself. The main aspect of this work was the use of linear system fault diagnosis to avoid the complexities that would otherwise be inevitable if nonlinear models are used. As stated in the introduction chapter there is certainly an increasing interest in the research literature in the use of non-linear methods and it is only a question of time before these techniques find their way into full application projects. However, as the feature of system supervision is to monitor the operation and performance of the system with respect to an expected point of operation, linear system methods are still very valid. Deviations from expected system behaviour could be used to monitor system performance changes as well as system component malfunctions. One drawback of the proposed method is that it has a relatively complicated procedure. The main contribution of this paper is the demonstration of a Markov parameter based fault detection and diagnosis of the linear system of different types. The proposed algorithms have been validated by means of two case studies. These suggest that the algorithm is very robust than the work already reported in the literature. The novelty of the work is that the Markov parameters are employed for the diagnosis of fault for the first time. Owing to the faster identification the work could be easily employed in an industrial environment for detecting the deterioration of parameters that age with time automatically.

VI. CONCLUSION

A new approach towards the fault diagnosis of linear dynamical systems using Markov parameters is proposed in this write up. The given discrete time system is excited using random input signals and corresponding output signals are

generated .Using this input /output combination the system identification is done using a mathematical approach. Markov parameters are used on performance index for classifying faulty and non faulty system. The artificial neural network trained using known faulty condition does the fault classification. The proposed diagnosis approach is illustrated on a suitable benchmark system with encouraging results. The future work is at present oriented towards the diagnosis of the actuator faults in linear system

APPENDIX

TABLE II
TRAINING PATTERNS OF CLASSIFIER

S.No	Neural Network Inputs					NN target
	Inp1	Inp2	Inp3	Inp4	Inp5	
1	1.00	1.00	0.75	-0.38	0.19	-0.3
2	1.00	1.00	0.66	-0.40	0.23	-0.2
3	1.00	1.00	0.59	-0.44	0.25	-0.1
4	1.00	1.00	0.54	-0.47	0.26	0
5	1.00	1.00	0.51	-0.49	0.25	0.1
6	1.00	1.00	0.50	-0.50	0.25	0.2
7	1.00	1.00	0.51	-0.49	0.26	0.3
8	1.00	1.00	0.54	-0.45	0.29	0.4
9	1.00	1.00	0.59	-0.38	0.36	0.5
10	1.00	1.00	0.66	-0.28	0.48	0.6
11	1.00	1.00	0.75	-0.13	0.69	0.7
12	1.00	1.00	0.86	0.08	0.99	0.8
13	1.00	1.00	0.99	0.33	1.42	0.9
14	1.00	1.00	1.14	0.65	2.00	1
15	1.00	1.00	1.31	1.04	2.77	1.1
16	1.00	1.00	1.50	1.50	3.75	1.2
17	1.00	1.00	1.71	2.04	4.98	1.3
18	1.00	1.00	1.94	2.67	6.50	1.4
19	1.00	1.00	2.19	3.39	8.35	1.5
20	1.00	1.00	2.46	4.20	10.56	1.6
21	1.00	1.00	2.75	5.13	13.19	1.7
22	1.00	1.00	3.06	6.16	16.28	1.8
23	1.00	1.00	3.39	7.30	19.87	1.9
24	1.00	1.00	3.74	8.57	24.03	2
25	1.00	1.00	4.11	9.97	28.81	2.1
26	1.00	1.00	4.50	11.50	34.25	2.2
27	1.00	1.00	4.91	13.17	40.43	2.3
28	1.00	1.00	5.34	14.99	47.39	2.4
29	1.00	1.00	5.79	16.96	55.21	2.5
30	1.00	1.00	6.26	19.08	63.96	2.6
31	1.00	1.00	6.75	21.38	73.69	2.7
32	1.00	1.00	7.26	23.84	84.48	2.8
33	1.00	1.00	7.79	26.47	96.41	2.9
34	1.00	1.00	8.34	29.29	109.54	3
35	1.00	1.00	8.91	32.30	123.96	3.1
36	1.00	1.00	9.50	35.50	139.75	3.2

37	1.00	1.00	10.11	38.90	156.99	3.3
38	1.00	1.00	10.74	42.51	175.77	3.4
39	1.00	1.00	11.39	46.33	196.14	3.5
40	1.00	1.00	12.06	50.36	218.26	3.6
41	1.00	1.00	12.75	54.63	242.20	3.7
42	1.00	1.00	13.46	59.12	268.04	3.8
43	1.00	1.00	14.19	63.86	295.83	3.9
44	1.00	1.00	14.94	68.80	325.72	4
45	1.00	1.00	15.71	74.00	357.90	4.1
46	1.00	1.00	16.52	79.50	392.44	4.2
47	1.00	1.00	17.35	85.12	429.03	4.3
48	1.00	1.00	18.15	91.25	475.70	4.4
49	1.00	1.00	19.00	97.17	510.49	4.5
50	1.01	1.01	20.12	104.21	557.77	4.6
51	0.99	0.99	20.47	111.61	602.83	4.7
52	1.03	1.03	22.44	118.63	648.43	4.8
53	0.98	0.98	22.12	126.12	698.23	4.9
54	1.00	1.00	23.60	110.64	773.47	5
55	1.03	1.03	25.59	139.11	839.74	5.1
56	0.98	0.98	24.79	180.94	921.82	5.2
57	1.02	1.02	27.35	156.98	959.57	5.3
58	0.98	0.98	26.35	98.81	1048.60	5.4
59	0.93	0.93	26.08	149.41	1225.00	5.5
60	1.00	1.00	29.71	-25.02	1560.70	5.6
61	1.01	1.01	31.12	200.69	1191.30	5.7
62	1.01	1.01	31.64	192.48	1242.00	5.8
63	0.38	0.38	2.57	85.42	1095.40	5.9
64	1.88	1.88	75.21	233.10	1410.00	6
65	1.17	1.17	42.58	289.54	-168.30	6.1
66	1.00	1.00	36.49	47.72	470.10	6.2
67	-0.14	-0.14	-16.15	574.99	-481.61	6.3
68	2.02	2.02	103.05	158.78	1620.10	6.4
69	0.32	0.32	9.20	279.04	-4039.70	6.5
70	0.65	0.65	21.84	419.89	5675.50	6.6

REFERENCES

- [1] N. L. C. Chui and J.M .Maciejowski, “ Sub space Identification – a Markov parameter approach”, *International journal of control*, vol78, no.17, 20, Nov. 2005, 1412-1436.
- [2] Datta B, “Numerical Methods for Linear Control Systems”, *Academic Press*, London 2005.
- [3] Gertler, J., fault Detection and Diagnosis in Engineering Systems”, *Marcel Dekker*, New York, 1998.
- [4] Chen, J., Patton, R.J. “Robust Model-Based Fault Diagnosis for Dynamic systems”, *Kluwer Academic Publishers*. Massachusetts, 1999.
- [5] Chiang L.H.Russell, E.L.Braatz R.D “Fault Detection and Diagnosis in Industrial Systems”, *Springer*, London, 2001.
- [6] Venkatasubramanian. V., Rengaswamy, R., Kavuri, S.N.m Yin, K., “A review of process fault detection and diagnosis” *Part-III: Process history based methods. computers & Chemical Engineering* ,No.27, pp 327-346, 2003c.
- [7] Venkatasubramanian, V., Rengaswamy, R., Yin, K., Kavuri, S.N., “A review of process detection and diagnosis.” *Part-I: Quantitative model-based methods. Computers & Chemical Engineering*, No.27, 293-311., 2003a.
- [8] Korbicz J., Koscielnly, J., M., Kowalezuk Z., Cholewa, W., “Fault Diagnosis. Models, Artificial Intelligence. Applications”. *Springer*. Berlin, 2004.

- [9] Gertler.J.,Luo.Q. “.Robust isolable models for fault diagnosis”. *AICHe Journal* ,No.35, pp 1856-1868, 1989.
- [10] Frank,P.M., “Fault diagnosis in dynamic systems using analytical and knowledge –based redundancy—a survey and some new results”, *Automatica* , No 26(3), pp 459-474,1990.
- [11] Mangoubi, R.S., “Robust Estimation and Failure Detection. A Concise Treatment”, *Springer*. London.,1998.
- [12] Isermann.R., “.Fault Diagnosis of machines via parameter estimation and knowledge processing—tutorial paper”, *Automatica*, No 29(4) , pp 815-835, 1993.
- [13] Maki,Y.,Loparo.K.A., “.A neural-network approach to fault detection and diagnosis in industrial processes”, *IEEE Transactions on Control Systems Technology* ,No 5(6) ,529-541,1997.
- [14] DE LA Fuente.M.J., Vega,P.,1999.Neural networks applied to fault detection of a biotechnical process. *Engineering Applications of Artificial Intelligence*, 12(5),569-584.
- [15] De Miguel. L.J., Mediavilla,M.,Peran,J.R. “.Decision-making approaches for a model-based FDI method”, *In: Preprints of the Third IFAC Symposium on Fault Detection, Supervision and Safety for Technical Processes*,Hull,U.K, pp719-725, 1997.
- [16] Frank and KoppenSeliger,B. “.Deterministic nonlinear observer based approaches to fault diagnosis”, *International Journal of Approximate Reasoning*, 161, 67-88,1997.
- [17] Garcia,F.,J.,Izquierdo,V.,De Miguel,L.,J.,Peran,J.R., “.Fault diagnostic system using analytical fuzzy redundancy”, *Engineering Applications of Artificial Intelligence* , No 1394, pp 441-450.,2000.
- [18] Ayoubi.m.isermann.R.. “.neuro-fuzzy systems for diagnosis”, *fuzzy sets and systems*, No89 (3), pp 289-307,1997.
- [19] Calado, J.M.F.Korbick, J.Patan k, patton, R.J.sa da costa J.M.G., “.Soft computing approaches to fault diagnosis for dynamic systems”, *European Journal of Control* , No 7,248-286.,2001.
- [20] Mendes,M.J.G.C.,Kowal, M.,Korbicz,J., sad a costa, J.M.G., “. Neuro-fuzzy structures in FDI systems.”, *Preprints of the 15 th IFAC World Congress*. Barcelona, Spain.P.2024, 2002.
- [21] Witezak,M.,Korbicz,J., “.Genetic programming based observers for non-linear systems”, *In: Preprints of the Fourth IFAC Symposium on Fault Detection, Supervision and safety for Technical Processes* ,Vol.2:Budapest,Hungary, pp 967-972, 2000.
- [22] Obuchowicz,A.,Patan,K., “. An algorithm of evolutionary search with soft selection for training multi-layer feedforward NNs.”, *In: Proceedings of the Third Conference NN&Their Applications*, Poleland , pp 123-128.,1997.
- [23] Chen, Y.M. and Lee, M.L., “.Neural Networks-Based Scheme for System Failure Detection and Diagnosis.” *Mathematics Computers Simulations*, Vol. 58, No. 2, pp. 101–109. 2002.
- [24] M.Borairi and H.Wang , “.Actuator and sensor fault diagnosis of non linear dynamic systems via genetic neural networks and parameter estimation techniques,” in *Proc.IEEE Int .Conf.Contr.Applicat.* vol1,pp . 278-282. 2002.
- [25] F.Filipetti,G.Franceschini,C.Tassoni and Vas,“. Recent developments of induction motor drives fault diagnosis using AI techniques,” *IEEE Trans. Industrial Elect*, vol147, no.5, pp994-1004,October 2000.
- [26] Vendatasubramanian,V., Rengaswamy.R., Kavuri.,S.N., “.A review of process fault detection and diagnosis.”, *Part-II: Qualitative models and search strategies.Computers & Chemical Engineering*,No 27, pp 313-326, 2003b.
- [27] Luis .J.De Miguel , L.Felipe Blaquez, “. Fuzzy logic based decision making for fault diagnosis in a dc motor “, *International journal on Engineering Applications of Artificial Intelligence* , Vol 18, pp 423 -450, 2005.
- [28] Gertler.J.J., “.All linear methods are Equal-and extendible to nonlinearities”, *In:Preprints of the Fourth IFAC Symposium on Fault detection,Supervision and safety for technical process* ,Voll.Budapest.Hungary, pp.52-63., 2000.
- [29] Kinnaert,M., “.Fault diagnosis based on analytical models for linear and nonlinear systems. A tutorial”, *In: Preprints of the Fifth Technical Processes*.Washington.DC, USA pp 37-50, 2003.
- [30] Lin,W,Wang H., “.Linearization techniques in fault diagnosis of non-linear systems.”, *Journal of Systems and Control Engineering Part I* 214(4),241-245., 2000.
- [31] Blaquez .L.F., de Miguel, L.J. “.Saturation effects detecting additive faults”, *In:Proceedings of the European Control Conference*. Porto, Portugal, pp.2340-2345.,2001
- [32] Kishnaswami.V.Rizzoni,G., “.Nonlinear parity equation residual generation for fault detection and isolation.”, *In:Preprints of the second IFAC Syposium on Fault Detection.Supervision and Safety for Technical Processes*. Vol.1.Espoo.,Finland ,pp .317-322, 1994.
- [33] Garcia,E.A.,Frank.P.M., “.Deterministic nonlinear observer based approaches to fault diagnosis”, *A survey. Control Engineering Practice* , No5(5), pp 663-670,1997.
- [34] Shumsky.A.,Y.,”.Robust residual generation for diagnosis of nonlinear systems: Parity relation approach”, *In:preprints of the Third IFAC Symposium on Fault Detection ,Supervision and Safety for Technical Processes*, Hull,UK, pp 867-872,1997.
- [35] Hammouri,H.,Kinnaert.M.,E1Yaagobi,E.H, “. Observer-based approach to fault detection and isolation for nonlinear systems”, *IEEE Transactions on Automatic Control* , No 44(10), pp 1879-1884,1997.
- [36] Blaquez.L.F., Foces.J.M, deMiguel. “.Additive fault detection in a real nonlinear system with saturation”, *In: Preprints of the Fifth IFAC Symposium on Fault Detection. Supervision and Safety for Technical Processes*.Washington.DC,USA,pp.1119-1124,2003.
- [37] Basseville.M.,mikiforov,I., “.Detection of Abrupt changes:Theory and Application.”, *Prentice-Hall* ,New York,1993.
- [38] Frank,P.M., “.Applications of fuzzy logic to process supervision and fault diagnosis.”, *In:Preprints of the Second IFAC Symposium on Fault Detection. Supervision and Safety for Technical Processes*.Vol.2.Esopp,Finland,pp.531-538,1994.
- [39] Gertler.J.J., Singer.D., “.A new structural framework for parity equation-based failure detection and isolation “, *Automatica* 26(2),381-388,1990.
- [40] Moonen M and Ramos J, “.A subspace algorithm for balanced state space system identification”, *IEEE Trans. on Automatic Control* , Vol. 38, pp.1727–1729, 1993.
- [41] Moonen M. and Vandewalle J, “.QSVD Approach to online and offline state-space identification”, *Int. J. Control*, Vol.51, pp.1133-1146, 1990.
- [42] Ljung, L. “.Systems Identification : Theory for the user” , *second edition* ,Prentice hall, Engle wood Cliffs, NJ,1999
- [43] Ogata. k, “.Modern Control Engineering”, Third Edition, PHI 2004.

Venugopal Manikandan was born in Coonoor, India in 1973 .He received B.E. Degree in Electrical and Electronics Engineering from Bharthiar University in 1993,M.E Degree in Applied Electronics from Bharthiar University in 2001.Currently he is doing PhD in fault diagnosis of linear systems from Anna University ,India. He is working as senior Lecturer in Coimbatore Institute of Technology; Coimbatore, India His current area of research includes fault diagnosis, Neural Networks and Fuzzy logic.

NanjundappanDevarajan was born in India . He received B.E Degree in Electrical and Electronics Engineering and M.E Degree in Power Systems from Government College of Technology, Coimbatore, India in 1982 and1989.respectively. He received PhD Degree in the area of control systems from Bharthiar University, India in 2000. He is working as Assistant Professor in Government College of Technology, Coimbatore, India. His areas of interests are control systems, electrical machines and power systems