

# RRNS-Convolutional Concatenated Code for OFDM based Wireless Communication with Direct Analog-to-Residue Converter

Shahana T. K., Babita R. Jose, K. Poulouse Jacob and Sreela Sasi

**Abstract**—The modern telecommunication industry demands higher capacity networks with high data rate. Orthogonal frequency division multiplexing (OFDM) is a promising technique for high data rate wireless communications at reasonable complexity in wireless channels. OFDM has been adopted for many types of wireless systems like wireless local area networks such as IEEE 802.11a, and digital audio/video broadcasting (DAB/DVB). The proposed research focuses on a concatenated coding scheme that improve the performance of OFDM based wireless communications. It uses a Redundant Residue Number System (RRNS) code as the outer code and a convolutional code as the inner code. Here, a direct conversion of analog signal to residue domain is done to reduce the conversion complexity using sigma-delta based parallel analog-to-residue converter. The bit error rate (BER) performances of the proposed system under different channel conditions are investigated. These include the effect of additive white Gaussian noise (AWGN), multipath delay spread, peak power clipping and frame start synchronization error. The simulation results show that the proposed RRNS-Convolutional concatenated coding (RCCC) scheme provides significant improvement in the system performance by exploiting the inherent properties of RRNS.

**Keywords**—Analog-to-residue converter, Concatenated codes, OFDM, Redundant Residue Number System, Sigma-delta modulator, Wireless communication

## I. INTRODUCTION

THE increasing demand for broadband communication systems with a greater range of services like video conferencing, internet services and digital multimedia applications has promoted the development of orthogonal frequency division multiplexing (OFDM) based systems. The OFDM is a digital multicarrier modulation method which distributes the data over a large number of closely spaced orthogonal carriers. The spectrum of each carrier has null at the centre frequency of each of the other carriers in the system. The available bandwidth is divided among the orthogonal carriers. Each carrier is then modulated by a low data rate stream with a conventional modulation scheme such as quadrature amplitude modulation (QAM) or quadrature phase shift keying (QPSK). OFDM provides high spectral efficiency

by spacing the channels close together. This will not result in interference between the carriers, as they are orthogonal to each other. In a coded OFDM (COFDM) system, signals are coded before transmission for forward error correction (FEC). The efficiency in spectrum usage and robustness to multipath fading make COFDM as a popular scheme for wideband digital communication.

Several papers are available in literature that deals with different coding schemes to improve the performance of multicarrier wireless communication systems. A multi-code direct sequence code division multiple access (DS-SS) system based on redundant residue number system (RRNS) as inner code and Reed-Solomon (RS) code as outer code is presented in [1]. The performance of a DS-SS system over bursty communication channels and multipath environment is concerned in [2], using a concatenated coding with convolutional code as outer code and RRNS as inner code. The design rules and general analytical upper bounds for parallel concatenated, serial concatenated, hybrid concatenated and self concatenated codes over AWGN and Rayleigh fading channels are presented in [3]. The suitability of OFDM as a modulation technique for wireless communication system is investigated in [4] in which a comparison with CDMA system is provided. A concatenated code for IEEE 802.11a system is proposed in [5], where a block Hamming code joins with a convolutional code, to achieve better system performance under fixed power and bit error rate (BER) requirements.

One of the major drawbacks of OFDM is that it generates signals with large amplitude variations resulting in high peak to average power ratio (PAPR). These large peaks increase the amount of intermodulation distortion resulting in an increase in the error rate. The system performance can be improved by minimizing the PAPR which allows a higher average power to be transmitted for a fixed peak power. A lot of research has been done that reduces the PAPR for OFDM based systems [6]–[8]. A method to enhance the bandwidth efficiency of a multicarrier CDMA system by using RNS representation for information symbols combined with PSK/QAM modulation and orthogonal spreading is presented in [9]. The performance evaluation of RNS based parallel communication scheme using orthogonal signaling with ratio static test over AWGN channel and multipath fading channel is demonstrated by Yang and Hanzo [10]–[11].

The direct conversion of analog signal to RNS domain using

Shahana T.K., Babita R. Jose and K. Poulouse Jacob are with Cochin University of Science and Technology, Kochi, Kerala, India. (Corresponding author phone: +91-484-2575007; fax: +91-484-2576368; e-mail: shahanatk@cusat.ac.in).

Sreela Sasi is with Department of Computer and Information Science, Gannon University, Erie, PA, USA

analog-to-residue (A/R) converter is available in literature. The direct analog-to-residue conversion proposed in [12] uses flash A/D converter, PLA, latches, code converter, buffers and XOR gates. An  $n$ -bit converter requires  $2^n - 1$  comparators and  $2^n$  resistors. So such A/R converters with high resolution are impractical to construct as the number of elements grows exponentially with resolution ' $n$ '. The design of a direct A/R converter using two stages of successive approximation A/D converters, a few modulo adders and a small look-up table is presented in [13]. An iterative flash A/R converter is presented in [14], which uses the principle of subranging to reduce the hardware complexity of flash A/D converters. These Nyquist rate A/R converters [12]-[14] are practically implemented only up to 10-12 bits of resolution due to component matching and circuit nonidealities. The sigma-delta ( $\Sigma\Delta$ ) modulator does not require stringent component matching, and hence sigma-delta based A/R converters with high resolutions of up to 20-bits are practically realizable [20].

This paper proposes a concatenated coding scheme consisting of RRNS as outer code and convolutional code as inner code for OFDM based wireless communication system. The conversion of analog signal to residue domain is done using a sigma-delta based parallel analog-to-residue converter. The proposed coding scheme combines the error detection and correction properties of RRNS with convolutional codes. The simulation results show that the RRNS-Convolutional concatenated coding (RCCC) scheme offers significant improvement in BER performance under different channel conditions. The performance of the system is analyzed for AWGN channel and multipath fading channel. The effect of frame start synchronization error and peak power clipping for PAPR reduction for the proposed coding scheme are also analyzed. The rest of the paper is organized as follows: Section II describes the principle of error correction with RRNS coding. Section III deals with the system model and explains the structure of transmitter and receiver. Section IV gives the simulation results, and the BER performance under different operating conditions is analyzed. Finally, Section V concludes the paper.

## II. ERROR CORRECTION WITH RRNS

The residue number system (RNS) is primarily used for high speed digital signal processing due to the modular carry free arithmetic operations. The nonweighted and nonpositional nature of residues offer fault tolerant properties to RNS. The RNS is defined by a set of relatively prime integers ( $m_1, m_2, \dots, m_u$ ) which are called the nonredundant moduli. Error detection and correction properties are introduced by inserting few redundant moduli. Thus redundant residue number system (RRNS) is defined by the moduli set ( $m_1, m_2, \dots, m_v, m_{v+1}, \dots, m_u$ ). The redundant moduli should be relatively prime to the nonredundant moduli and should satisfy the condition ( $m_{v+1}, \dots, m_u$ )  $>$   $\max(m_1, m_2, \dots, m_v)$ . The total dynamic range of RRNS is

given by  $M_T = \prod_{i=1}^u m_i$ . This total range  $[0, M_T)$  is divided

into two adjacent intervals in terms of the ranges defined by the nonredundant and redundant moduli. The interval  $[0, M)$  is

called the *legitimate range*, where  $M = \prod_{i=1}^v m_i$  and the

interval  $[M, M_T)$  is called the *illegitimate range*. In order for RRNS to have self checking, error detection and error correction properties, the information or data has to be constrained within the legitimate range. It has been shown that RRNS with  $(u - v)$  redundant moduli can detect  $(u - v)$  errors and can correct up to  $\lfloor (u - v)/2 \rfloor$  errors, where  $\lfloor \cdot \rfloor$  denotes the integer part [15].

An error correction scheme with RRNS [16], [17] is given in Fig. 1. Here, the binary number  $Z'$  is generated from the received nonredundant residue digits ( $z_1, z_2, \dots, z_v$ ) using a reverse converter based on Chinese Remainder Theorem (CRT). An auxiliary set of residues  $|Z'|_{m_{v+1}}, |Z'|_{m_{v+2}}, \dots, |Z'|_{m_u}$  corresponding to the redundant channels are generated from the output  $Z'$  by forward conversion. The error syndrome for each redundant channel is calculated as in (1), by comparing the received redundant residue digit with the auxiliary residue generated.

$$S_{m_i} = z_{m_i} - |Z'|_{m_i} \quad \text{for } i = v + 1, \dots, u. \quad (1)$$

If all the error syndromes are zeros, then all the received residue digits are correct and hence there is no error present. If any one of the redundant residue channel is in error, the corresponding error syndrome is nonzero and the other syndromes are zeros. In such cases the output calculated using the nonredundant residues is correct. If there is an error in the nonredundant channel, all the syndromes are nonzeros. In this case a correction has to be applied to the output  $Z'$ . There is a unique error corresponding to each combination of the syndromes. So error correction can be done with the help of a look up table (LUT). The LUT is addressed by the syndrome values, and the size of the LUT required to store the correction factor is determined using (2). The correction factor (CF) from the LUT is added to the output  $Z'$  from reverse converter to produce the correct output  $Z$ .

$$N = \left( 2 \sum_{i=1}^v m_i - 1 \right) + \left( \sum_{i=v+1}^u m_i \right) - 1 \quad (2)$$

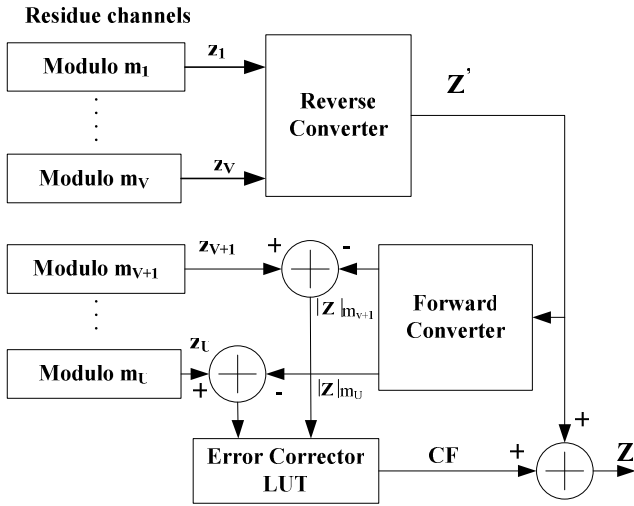

Fig. 1 Principle of error correction with RRNS

### III. SYSTEM DESCRIPTION

This section illustrates the signal flow through a typical wireless digital communication system that includes analog-to-residue converter, concatenated forward error control coding, interleaving and deinterleaving, orthogonal digital modulation and channel impairments. Concatenated coding is a good way to create long powerful codes with large coding gain and reduced decoding complexity by combining relatively simple channel codes [18]. The proposed RRNS-Convolutional concatenated coding corrects the errors using the outer RRNS decoder that are not corrected by the inner decoder. Thus better BER performance is achieved by exploiting the properties of RRNS.

#### A. Sigma-Delta based Parallel Analog-to-residue Converter

The A/R converter architecture based on sigma-delta based modulator is shown in Fig. 2. The analog input is sampled at an oversampling ratio (OSR) much greater than Nyquist rate. The order of the modulator ' $L$ ', the OSR ' $M$ ' and the number of quantizer bits ' $B$ ' are selected to meet the dynamic range requirements for various resolutions. The binary bits from sigma-delta ( $\Sigma\Delta$ ) modulator are given to the following RNS based decimation filter. The residue digits are generated in parallel at the decimator outputs.

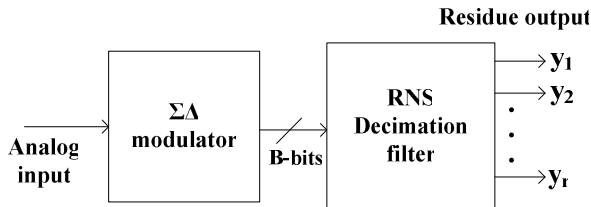

Fig. 2 Sigma-delta based parallel A/R converter

#### 1) Sigma-delta modulator

Sigma-delta modulator trades resolution in time for resolution in amplitude. Oversampling and noise-shaping are the two key techniques on which the modulator relies. Oversampling reduces the baseband quantization noise, and

noise-shaping moves quantization noise from the baseband to higher out-of-band frequencies. The oversampling and noise shaping techniques are combined to achieve superior resolution with relaxed requirements on analog hardware compared to Nyquist rate A/D converters [19].

Multistage noise shaping (MASH) is an efficient way of implementing higher-order  $\Sigma\Delta$  modulators where multiple lower order stages are cascaded such that each stage processes the quantization noise of the previous stage. In cascaded or MASH topology, the outputs of each individual stage go to a digital error cancellation logic where the quantization noise of all stages except that of the last one is removed. The quantization noise of the remaining stage is filtered by the noise transfer function  $(1-z^{-1})^L$ , where  $L$  is the modulator order of the overall  $\Sigma\Delta$  modulator. A fourth order  $\Sigma\Delta$  modulator can be implemented using two second order stages as shown in Fig. 3. The main advantage of MASH architecture is the high degree of noise shaping without any stability problems.

The dynamic range in dB of an A/D converter with  $n$ -bit resolution is given in (3). The theoretical DR for a  $\Sigma\Delta$  modulator with order ' $L$ ', oversampling ratio ' $M$ ', and number of quantizer bits ' $B$ ' is given in (4). Using (3) and (4), the required modulator order, oversampling ratio and the number of quantizer bits are calculated for a given resolution.

$$DR = 6.02 * n + 1.76 \quad (3)$$

$$DR = \frac{3}{2} \frac{2L+1}{\pi^{2L}} M^{2L+1} (2^B - 1)^2 \quad (4)$$

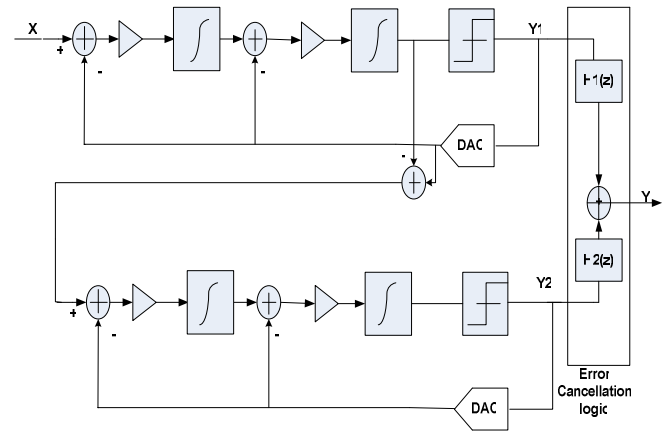

Fig. 3 A 2-2 cascaded MASH architecture

#### 2) RNS based decimation filter

The decimation filter consists of a lowpass filter and a downsampler. It acts as antialiasing filter and removes the out-of-band quantization noise produced by the  $\Sigma\Delta$  modulator. Upon filtering, the output is resampled at the Nyquist rate. The decimation filter receives the output of  $\Sigma\Delta$  modulator as its input. The decimation filter operates in the RNS domain defined by a proper moduli set that provides sufficient dynamic range avoiding overflow. The moduli set consists of relatively prime integers and are selected in such a way that the number of bits for representing each modulus is greater than

the maximum number of bits from the modulator. This eliminates the need for a forward converter.

The RNS based decimation filter is shown in Fig. 4, where the multiply and accumulate (MAC) operations are performed in RNS domain. The structure of a particular modulo filter channel based on modulus ' $m_i$ ' is shown in Fig. 5, where  $\otimes$  and  $\oplus$  represent modulo multiplication and modulo addition respectively. The filter coefficients are directly represented in residue form. The downsampler in each channel resamples the output at Nyquist rate. Here all the residues are generated in parallel at the filter outputs.

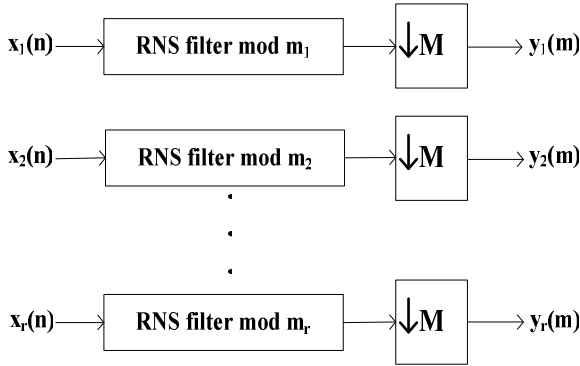

Fig. 4 RNS based decimation filter

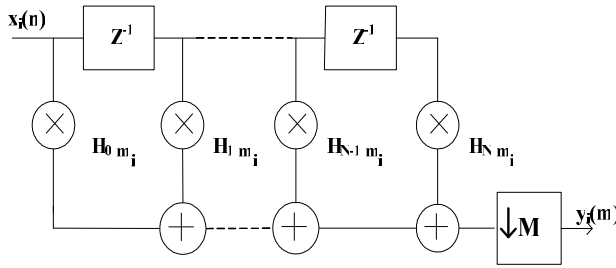

Fig. 5  $i^{\text{th}}$  modulo filter channel

### B. Transmitter Model

The functional block diagram shown in Fig. 6 illustrates the transmitter section of the proposed communication system. The  $N$ -bit information symbols are first converted to RRNS representation by a sigma-delta based parallel A/R converter. The moduli set of RRNS is selected such a way that it offers redundancy and sufficient dynamic range for unique and unambiguous information representation. An information symbol  $X$ , is represented in RRNS as  $(x_1, x_2, \dots, x_v, x_{v+1}, \dots, x_u)$  with respect to a moduli set  $(m_1, m_2, \dots, m_v, m_{v+1}, \dots, m_u)$ , where  $x_i = X \text{ modulo } m_i$  for  $i = 1$  to  $u$ . This is the outer RRNS coding. In the proposed system, A/R converter with 8-bit resolution is considered and RRNS moduli set is selected as (5, 7, 8, 9, 11) where (5, 7, 8) forms the nonredundant moduli and (9, 11) forms the redundant moduli. This allows detection of errors in two residue digits and can correct single residue digit errors.

The residue digits are interleaved and then applied to a convolutional encoder for inner encoding. The proposed system uses industry standard  $1/2$  rate convolutional encoder with constraint length of 7, as shown in Fig. 7. The generator

polynomials are:  $g_1 = 133_8$  and  $g_2 = 171_8$ . The interleaved and rearranged data bits are mapped into signal constellation points according to the type of modulation used. Differential QPSK is used as the modulation scheme for this work. Serial-to-parallel conversion is done for the modulated data. An Inverse Fast Fourier Transform (IFFT) is taken for implementing OFDM. The IFFT transforms the subcarriers from the frequency domain into the corresponding time domain. The OFDM signal is represented as in (5).

$$S(n) = \frac{A}{M} \sum_{i=0}^{M-1} x_i(n) \exp(2\pi f_i n) \quad \text{for } 0 \leq n, i < M \quad (5)$$

where  $A$  is the scaling factor,  $M$  is the total number of subcarriers,  $x_i(n)$  is the  $n^{\text{th}}$  bit of the  $i^{\text{th}}$  data stream and

$f_i = f_c + \frac{i}{T}$ , for  $i = 0, 1, \dots, M - 1$ . ' $T$ ' is the symbol

duration for the information sequence, and  $f_c$  is the centre frequency of the subcarriers. A guard band interval is inserted to avoid intersymbol interferences (ISI) and intercarrier interferences (ICI) caused by the multipath fading. Finally, the signal is transmitted after radio frequency upconversion.

### C. Receiver Model

The channel attenuates the transmitted signals, delays it in time, and corrupts them by addition of Gaussian noise. The effects of multi-path delay spread are accounted by using a lowpass finite impulse response (FIR) filter model. The length of the filter represents the maximum delay spread, and the magnitude of filter coefficients represents the reflected signal amplitudes. The received signal can be represented as in (6), assuming  $P$  resolvable frequency selective paths for the multipath channel,

$$r(t) = \sum_{p=0}^{P-1} \alpha_p(t) s(t - \tau_p) + N(t) \quad (6)$$

Here,  $N(t)$  represents a stationary zero-mean Gaussian random process with single sided power spectral density of  $N_0$ , and  $\alpha_p$  and  $\tau_p$  are the complex valued channel gain and time delay of the  $p^{\text{th}}$  path respectively.

The functional block diagram of the receiver section is shown in Fig. 8. The received signal is downconverted from radio frequency and synchronized with the symbol interval. The guard band, which is inserted for eliminating the ISI and ICI effects, is removed. The symbol constellations corresponding to the original transmitted spectrum are recovered by passing the signal through FFT. The resulting data are deinterleaved and channel decoded. The convolutional encoding applied to the data is decoded by Viterbi decoding. The output data is deinterleaved and given to RRNS decoder. The binary symbol is generated from the nonredundant residue digits using a reverse converter based on CRT. The error corrector LUT addressed by the error syndromes gives out a correction factor. This is added to the output of the reverse converter to get the corrected binary symbol. The proposed model uses two redundant moduli and three nonredundant

moduli. So the size of the LUT becomes  $[ 2 * \{ (5-1) + (7-1) + (8-1) \} + \{ 9 + 11 \} - 1 ] = 53$  address locations. Thus RRNS

decoding corrects single residue digit errors that are not corrected by Viterbi decoding.

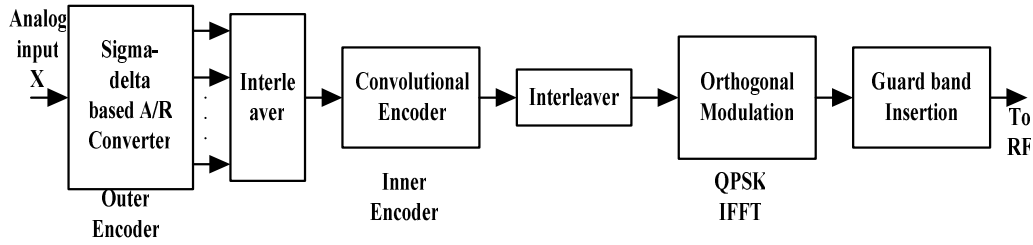

Fig. 6 Block diagram of transmitter section

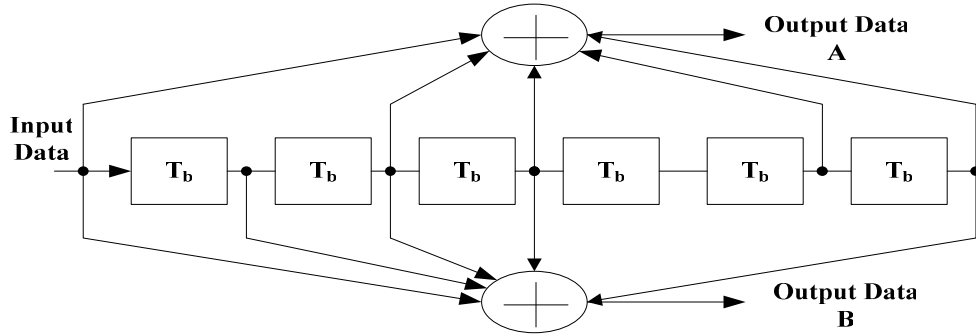

Fig. 7 Convolutional encoder

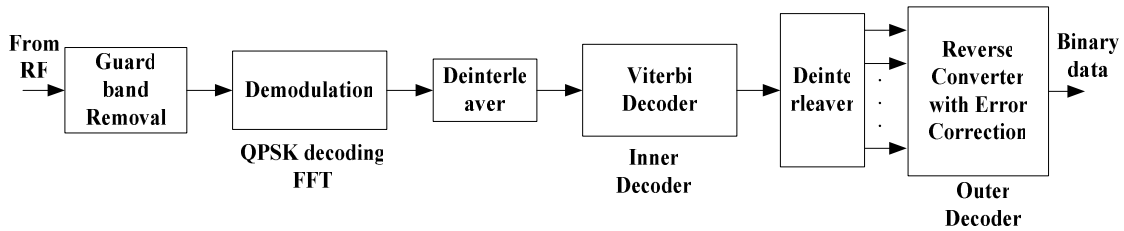

Fig. 8 Block diagram of receiver section

IV. SIMULATION RESULTS AND PERFORMANCE ANALYSIS

The A/R converter is simulated for 8-bit resolution using the moduli set as (5, 7, 8, 9, 11) avoiding overflow. The modulator used is 2-2 cascaded MASH architecture with OSR of 16 and single-bit quantizer and simulated using MATLAB® *Simulink models*. The communication model is implemented in MATLAB®. The OFDM system is simulated with 800 subcarriers using differential QPSK modulation scheme and with the FFT and IFFT sizes of 2048 points. The BER performance of the proposed system using RCCC scheme is evaluated under different operating conditions. This coding scheme offers significant improvement in BER performance for the OFDM system. The simulations are carried out to evaluate the system performance under additive white Gaussian noise and multipath fading effects. The PAPR reduction by peak clipping under different clip compression ratios is found out for this coding scheme. The BER performance with cyclic prefixed guard band for different

frame start synchronization errors is also analyzed.

A. Additive White Gaussian Noise Tolerance

The channel adds zero-mean Gaussian noise to the transmitted signal and the BER performances of uncoded, convolutional coded, and concatenated coded system are obtained. The simulations are carried out by varying the signal-to-noise ratio (SNR), and the BER values are plotted against the channel SNR for different cases as shown in Fig. 9. The simulation results show that the proposed RCCC scheme offers a coding gain of about 4 dB at BER of  $10^{-2}$ . This system can tolerate SNR > 8 – 10 dB with QPSK modulation and RRNS-Convolutional concatenated coding scheme.

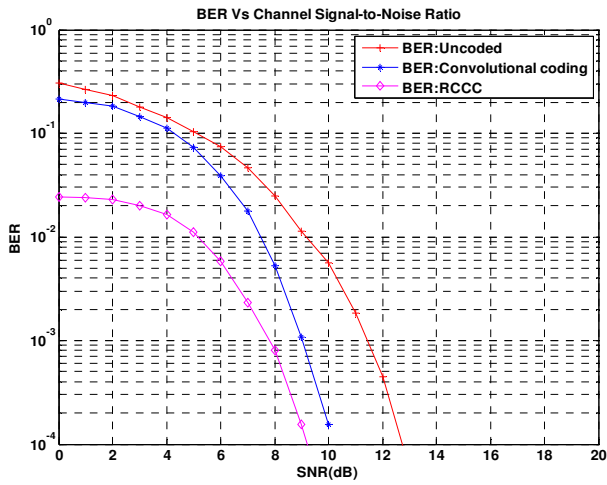

Fig. 9 BER versus SNR for uncoded, convolutional coded and RCCC OFDM system

**B. Multipath Delay Spread Immunity**

One of the important properties of OFDM is its robustness to multipath delay spread. This is achieved by distributing the digitally encoded symbols over several orthogonal subcarriers in order to reduce the symbol rates. In a frequency-selective multipath fading channel, the base pulses of the original OFDM signal and the delayed version of the signal are no longer orthogonal. This leads to severe ISI as the orthogonality of the signals is lost. To address this problem, a guard interval is inserted between OFDM symbols.

The proposed OFDM system uses cyclic prefix as guard band where the last 256 samples are copied and inserted in front of the symbol. Now a multipath reflection that stays within the guard interval will not cause interference problems. For a channel bandwidth of 1.25 MHz, 256 samples as the guard period correspond to a reflected signal with an additional path length of 61.4 km. The simulation is carried out for a multipath signal containing single reflected signal which is 3 dB weaker than the direct signal. It is sufficient to take a 3 dB weaker signal as the signals weaker than this do not cause measurable errors. The multipath modeling is done by using a lowpass FIR filter function. The length of the filter corresponds to the delay in terms of number of samples and filter coefficients correspond to the reflected signal amplitudes. The BER performance for different delay spreads is obtained for the three types of OFDM systems as shown in Fig. 10. The tolerable multipath delay spread corresponds to the time of cyclic prefix of the guard period. The results show that the proposed coding scheme offers additional multipath delay spread immunity for the OFDM system. When the delay spread is longer than the guard period, the BER increases rapidly due to the increased ISI. But the RCCC scheme causes the BER to increase at a lesser rate compared to the other two schemes.

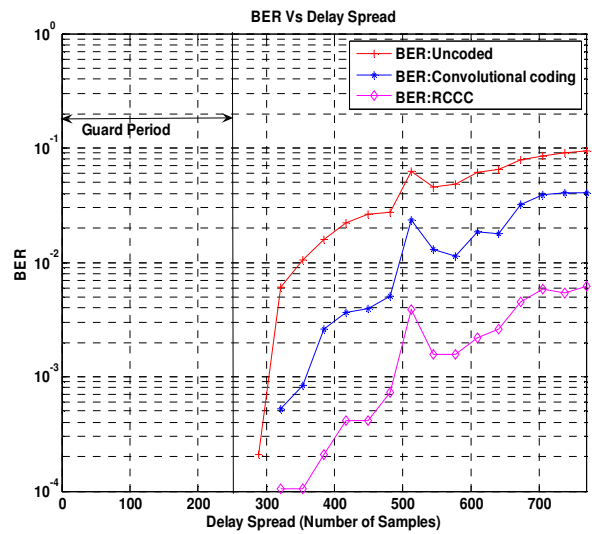

Fig. 10 BER versus multipath delay spread for uncoded, convolutional coded and RCCC OFDM system

**C. Effect of Frame Synchronization Errors**

The cyclic prefix guard band insertion provides tolerance to frame start time error as well. The BER performance of the system for different timing errors specified in terms of number of samples is shown in Fig. 11. The results show that the starting synchronization errors up to the guard band period are tolerable. This is due to the fact that the orthogonality is maintained during the guard period. Also the proposed coding scheme keeps the BER of the system less than that for the uncoded and convolutional coded systems. If multipath delay spread is taken into consideration, this will reduce the effective stable time of the guard period. Hence multipath delay spread leads to reduced timing error tolerance. But the RCCC scheme offers better timing error tolerance in presence of multipath signals for a particular BER.

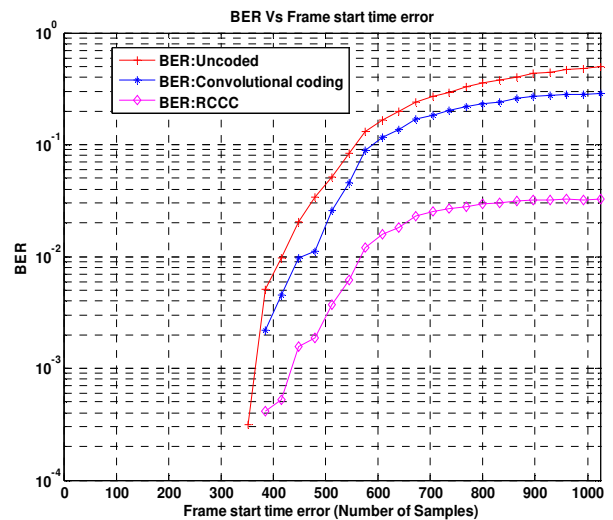

Fig. 11 BER versus frame start time error for uncoded, convolutional coded and RCCC OFDM system

#### D. Peak Power Clipping for PAPR Reduction

The signal peak at the transmitter is clipped to reduce the PAPR value without much increase in the BER. As the clipping level is increased the PAPR reduces, but the BER is increased. The BER performance for different clip compression ratios in dB is shown in Fig. 12, where the clip compression ratio (CR) is defined as the ratio of the peak power of the signal before clipping to the peak power of the clipped signal. The proposed RCCC coding scheme allows the signal to clip heavily without significant increase in BER. The results show that the proposed system can operate at a BER of  $10^{-3}$  with a clip compression ratio of 15 dB. Fig. 13 shows the BER performance of the proposed system for different clip compression ratios with varying amount of channel noise. For high value of CR, more signal amplitude is clipped resulting in high BER. Hence as CR is increased, the required SNR to achieve the same BER performance is increased. This is due to the increased probability of existence of OFDM signal amplitudes higher than the clipping level. The PAPR values for different clip compression ratios are shown in Table I. The performance of the system for CR=2dB is very close to the no clipping performance. There is a trade off between BER performance and PAPR reduction.

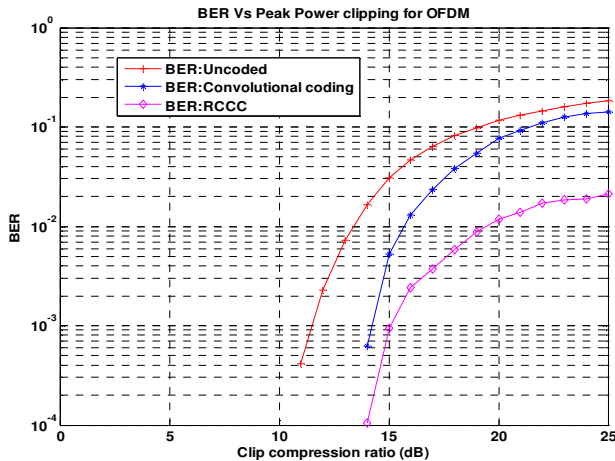

Fig. 8 BER versus peak power clipping for uncoded, convolutional coded and RCCC OFDM system

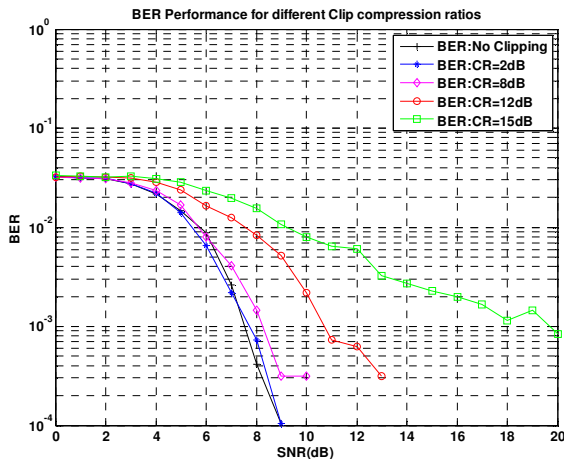

Fig. 9 BER versus channel noise of the RCCC OFDM system for different peak power clipping levels

TABLE I  
PAPR FOR DIFFERENT PEAK POWER CLIPPING

Clipping Ratio CR (dB)	Peak to Average Power Ratio, PAPR (dB)	
	Maximum	Average
No clipping (0 dB)	9.1417	5.5961
2 dB	9.126	5.5905
5 dB	8.7477	5.4783
8 dB	8.3789	4.8693
10 dB	8.2788	4.1188
12 dB	7.8339	3.3014

#### V. CONCLUSION

The research proposes RRNS-convolutional concatenated coding (RCCC) scheme for an OFDM based wireless communication system with a sigma-delta based parallel A/R converter. The concatenated code uses RRNS code as the outer code and convolutional code as the inner code. At the receiver, errors that are not corrected by Viterbi decoding will get corrected by the RRNS decoding due to the redundancy introduced. The performance of this system is analyzed for different channel conditions. The simulation results show that RCCC scheme offers improved BER performance in presence of additive white Gaussian noise and multipath delay spread. The guard band insertion with cyclic prefixing provides tolerance to multipath delay spread and frame start synchronization errors. This coding scheme makes the OFDM system more robust against multipath effects and timing errors. Also, the signal can be heavily clipped to reduce the PAPR without significant increase in BER for the RCCC OFDM system. The performance analysis shows that the proposed RCCC scheme is suitable for OFDM as it improves the tolerance of system to channel noise, mutipath effects, timing errors and peak power clipping.

#### REFERENCES

- [1] L. L. Yang and L. Hanzo, "Residue number system based multiple code DS-CDMA systems", Proc. of IEEE 49<sup>th</sup> Vehicular Technology Conference, Houston, USA, Vol.2, pp. 1450-1454, May 1999.
- [2] A.S. Madhukumar and F. Chin, "Performance of a residue number system based DS-CDMA system over bursty communication channels", Proc. of IEEE Vehicular Technology Conference (VTS-Fall VTC 2000), Vol.5, pp.2433-2440, 2000.
- [3] D. Divsalar and F. Pollara, "Serial and hybrid concatenated codes with applications", Proc. of International Symp. on Turbo Codes, Brest, France, pp. 80-88, 1997
- [4] E. Lawrey, "The suitability of OFDM as a modulation technique for wireless telecommunications, with a CDMA comparison", BE Thesis, James Cook University, October 1997.
- [5] C.S. Tsai and B.C. Huang, "Concatenated codes design for OFDM based wireless local area networks", Third international working conference on Performance Modelling and Evaluation of Heterogeneous Networks (HET-NETs), West Yorkshire, U.K, July 2005.
- [6] B. Tarokh and H.R. Sadjadpour, "Construction of OFDM M-QAM sequences with low peak-to-average power ratio", IEEE Trans. on Communications, Vol.51, No.1, pp. 25-28, January 2003.
- [7] D.H. Guo and C.Y. Hsu, "The economical PAPR minization scheme for combinative coding technique applied OFDM communication system", Analog Integrated Circuits and Signal Processing, vol.46, pp.139-144, February 2006.

- [8] S. U. Tezeren, "Reed-Muller codes in error detection in wireless adhoc networks", M.S. Thesis, Naval Postgraduate School, March 2004.
- [9] A.S.Madhukumar and F.Chin, "Residue number system-based multicarrier CDMA for high-speed broadband wireless access", *IEEE Transactions on Broadcasting*, Vol. 48, No. 1, March 2002, pp. 46-52.
- [10] L. L. Yang and L. Hanzo, "A residue number system based parallel communication scheme using orthogonal signaling: Part I- System outline", *IEEE Trans. on Vehicular Technology*, vol.51, No.6, pp.1534-1546, November 2002.
- [11] L. L. Yang and L. Hanzo, "A residue number system based parallel communication scheme using orthogonal signaling: Part II- Multipath fading channels", *IEEE Trans. on Vehicular Technology*, vol.51, No.6, pp.1547-1559, November 2002.
- [12] S.Mandyam and T.Stouraitis, "Efficient analog-to-residue conversion schemes", *Proc. IEEE International Symposium on Circuits and Systems*, New Orleans, LA, May 1990, pp. 2885-2888.
- [13] D. Radhakrishnan and A.P. Preethy, "A parallel approach to direct analog-to-residue conversion", *Information Processing Letters*, Vol. 69, No. 5, March 1999, pp. 249-252.
- [14] D. Radhakrishnan and A.P. Preethy, "A direct analog-to-residue converter", *IEEE Region 10 International Conference on Global Connectivity in Energy, Computer, Communication and Control (TENCON1998)*, Vol.2, 1998, pp.336-339.
- [15] M.A. Soderstrand, W.K. Jenkins, G.A. Jullien, and F.J. Taylor, *Residue number system arithmetic: modern applications in digital signal processing*, IEEE Press, New York, 1986.
- [16] R.J. Cosentino, "Fault tolerance in a systolic residue arithmetic processor array", *IEEE Trans. on Computers*, Vol. 37, No. 7, pp. 886-890, July 1988.
- [17] A.P. Preethy, D. Radhakrishnan and A. Omondi, "Fault-tolerance scheme for an RNS MAC: performance and cost analysis", *Proc. of IEEE International Symposium on Circuits and Systems (ISCAS 2001)*, Sydney, Australia, Vol. 2, pp. 717-720, May 2001.
- [18] Peter Sweeney, *Error control coding: from theory to practice*, John Wiley & Sons Ltd., Baffins Lane, Chichester, West Sussex PO19 1UD, England, 2002.
- [19] S.R.Norsworthy, R.Schreier and G.C.Temes, *Delta-Sigma Data Converters, Theory, Design, and Simulation*, Piscataway, NJ: IEEE Press, 1997.
- [20] Shahana T.K., Babita R. Jose, K. Poullose Jacob and Sreela Sasi, "A Novel Sigma-Delta based Parallel Analog-to-Residue Converter", *Paper Communicated and under revision with International Journal of Electronics*, Taylor and Francis Ltd.

of Professor and Head of the Department of Computer Science. He has served as a Member of the Standing Committee of the UGC on Computer Education and Development. He is on the editorial board of two international journals and has more than 80 papers in various international journals and conferences to his credit. His research interests are in Information Systems Engineering, Intelligent Architectures and Networks, Wireless Communication and Low-power design.

**Sreela Sasi** is an Associate Professor at Gannon University, Erie, Pennsylvania, USA. She did her Ph.D. in Computer Engineering from Wayne State University, Michigan, USA, M.S. in Electrical Engineering from University of Idaho, Idaho, USA, and B.S. in Electronics and Communication Engineering from University of Kerala, India. Research interests include VLSI Design, Computer Vision and Intelligent System Design. She is a Senior Member of IEEE, member of Eta Kappa Nu, IEEE Computer Society, IEEE Women in Engineering, ISTE (L)(India), and Fellow IETE (India).

**Shahana T.K.** received her Bachelors Degree in Electronics and Communication Engineering from Mahatma Gandhi University, Kerala, India in 1997 and Masters Degree in Digital Electronics from Cochin University of Science and Technology, Kerala, India in 1999. She is a Lecturer in School of Engineering, and is also working towards her Ph. D. degree in Department of Computer Science, Cochin University of Science and Technology. Her research interests primarily focus on the design of Mutli-standard Wireless Transceivers, Signal Processing for Communication, RNS-based arithmetic circuits and Low-power design.

**Babita R. Jose** received the B. Tech degree in Electronics and Communication Engineering from Mahatma Gandhi University, Kerala, India in 1997 and Masters Degree in Digital Electronics from Karnataka University, India in 1999. She also holds a M.S degree in System on Chip designs from Royal Institute of Technology (KTH), Stockholm, Sweden. Currently, she is serving as a Lecturer in School of Engineering, and also working towards her Ph. D. degree at School of Engineering, Cochin University of Science and Technology. Her research interests are focused on development of System on chip architectures, Multi-standard Wireless Transceivers, Low-power design of sigma delta modulators.

**K. Poullose Jacob**, a National Merit Scholar all through, got his degree in Electrical Engineering in 1976 from University of Kerala, followed by his M.Tech. in Digital Electronics and Ph. D. in Computer Engineering from Cochin University of Science and Technology (CUSAT), Kochi, India. He has been teaching at CUSAT since 1980 and currently occupies the position