

Packet Forwarding with Multiprotocol Label Switching

R.N.Pise, S.A.Kulkarni, and R.V.Pawar

Abstract—MultiProtocol Label Switching (MPLS) is an emerging technology that aims to address many of the existing issues associated with packet forwarding in today's Internetworking environment. It provides a method of forwarding packets at a high rate of speed by combining the speed and performance of Layer 2 with the scalability and IP intelligence of Layer 3. In a traditional IP (Internet Protocol) routing network, a router analyzes the destination IP address contained in the packet header. The router independently determines the next hop for the packet using the destination IP address and the interior gateway protocol. This process is repeated at each hop to deliver the packet to its final destination. In contrast, in the MPLS forwarding paradigm routers on the edge of the network (label edge routers) attach labels to packets based on the forwarding Equivalence class (FEC). Packets are then forwarded through the MPLS domain, based on their associated FECs, through swapping the labels by routers in the core of the network called label switch routers. The act of simply swapping the label instead of referencing the IP header of the packet in the routing table at each hop provides a more efficient manner of forwarding packets, which in turn allows the opportunity for traffic to be forwarded at tremendous speeds and to have granular control over the path taken by a packet. This paper deals with the process of MPLS forwarding mechanism, implementation of MPLS datapath, and test results showing the performance comparison of MPLS and IP routing. The discussion will focus primarily on MPLS IP packet networks — by far the most common application of MPLS today.

Keywords—Forwarding equivalence class, incoming label map, label, next hop label forwarding entry.

I. TRADITIONAL IP ROUTING

IN traditional routing environments, a packet is forwarded through a network on a hop-by-hop basis using interior gateway protocols (IGPs) such as routing information protocol (RIP) and open shortest path first (OSPF), or exterior gateway protocol (EGPs) such as border gateway protocol (BGP). IP packets contain a header with sufficient information that enables them to be forwarded through a network. Traditionally packet forwarding has been based upon datagram routing. The routing technique used in IP networks is a destination-based routing paradigm. This means that an IP packet is routed through the network based upon the destination address contained within the packet header [5].

R.N. Pise is with Vishwakarma Institute of Technology, 666, Upper Indiranagar, Bibwewadi, Pune, Maharashtra, 411 037, India (phone: 91-20-24282294; fax: 91-20-24280926; e-mail: nishanpise@yahoo.com).

The forwarding mechanism utilized by IP networks is "hop-by-hop" routing, which means that every packet entering a router is examined and a decision is made as to where to send the packet (i.e., what is the packet's "next hop"). In this manner, a packet is routed through a network from its source to its destination. Since the packets are individually routed through a network and don't follow a predetermined path, the network is said to be connectionless. In order to properly route a packet, a router must be able to determine the next hop for the packet. Routing protocols, such as Open Shortest Path First (OSPF), enable each router to learn the topology of the network. The routers build forwarding tables using the information provided by routing protocols. The tables identify the appropriate next hop for all known IP destination addresses. Routers generally store IP prefixes rather than complete IP addresses in their forwarding tables [6].

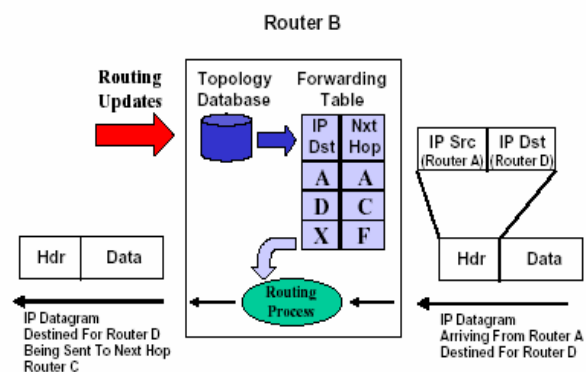

Fig. 1 Route lookup

The router performs a look-up based on the destination IP address in the packet header. This is done by referencing the destination Layer 3 addresses against a routing table for a next hop entry as shown in Fig. 1. Each router that a packet traverses must do a route lookup, based on the destination IP address. This must be performed to determine the packet's next hop in its path to deliver the packet to its final destination. The Layer 2 destination address is then replaced with the address of the next hop's Layer 2 address, and the source Layer 2 address is then replaced with the Layer 2 address of the current router. The source and destination IP addresses are left unchanged. The packet is forwarded out on the appropriate interface based on a certain metric. The packet

follows the same process on a hop-by-hop basis through the network until it reaches its destination.

Running IGP's such as RIP and OSPF fall short when introducing the need for network management, traffic engineering and scalable IP services [3]. Refer Fig. 2. Router C must make its forwarding decisions for packets destined to Router F based on the metrics defined by the IGP being used. All packets coming from Router A or B destined for Router F

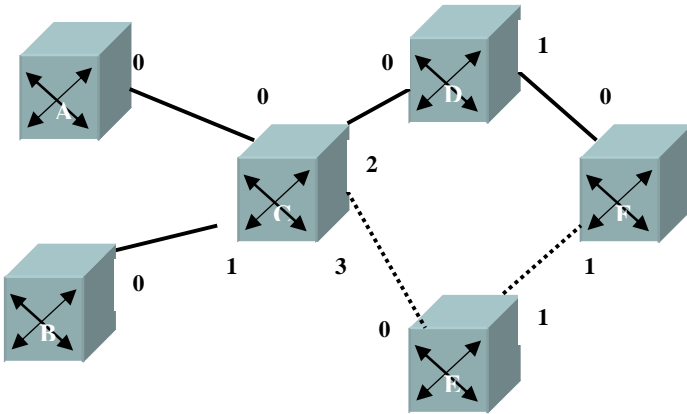

Fig. 2 Packet forwarding

will be forwarded in the same way, along the same path with the preferred metric. Therefore, if the path to router F via Router D is a higher bandwidth—the path via Router D would be the only one used unless a network failure occurred.

II. MULTI PROTOCOL LABEL SWITCHING

Label switching technology is a result of the desire to combine the benefits of switching technologies that live in the core of the network with the benefits of IP routing technologies that live at the edge of the network. MPLS is an IETF standard approach to integrate the best attributes of traditional layer 2 and layer 3 technologies. It defines a set of protocols and procedures that enable the fast switching capabilities of ATM and frame relay to be utilized by IP networks. The key concept in MPLS is identifying and marking IP packets with labels and forwarding them to a router, which then uses the labels to switch the packets through the network. The labels are created and assigned to IP packets based upon the information gathered from existing IP routing protocols [3].

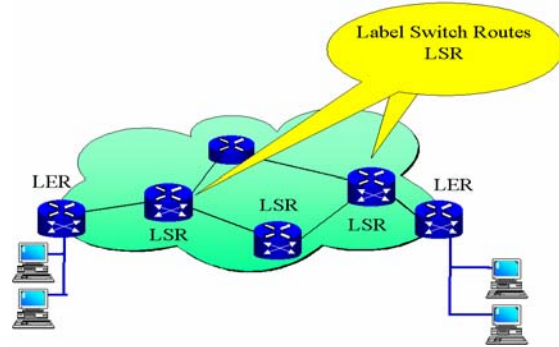

Fig. 3 MPLS Domain

Routers on the edge of the network (label edge routers [LERs]) attach labels to packets based on a forwarding equivalence class (FEC). Packets are then forwarded through the MPLS network, based on their associated FECs, through swapping the labels by routers or switches in the core of the network called label switch routers (LSRs), to their destination. (Refer Fig. 3).

MPLS also makes it possible to have granular control over a packet's path by referencing the incoming labels to the LIB (Label Information Base). As the network is established and signaled, each MPLS router builds a Label Information Base (LIB)—a table that specifies how to forward a packet. This table associates each label with its corresponding FEC and the outgoing port to forward the packet to. This LIB is typically established in addition to the routing table and Forwarding Information Base (FIB) that traditional routers maintain.

Consider again Fig. 2. The following table I is an example of Router C's LIB. Now the Packets destined to router F originating from Router A will follow the solid path. Packets originating from Router B will follow the dotted path. This is

TABLE I
LABEL INFORMATION BASE

Interface IN	Label In	Destination	Exit Interface	Label Out
S2	60	F	S0	20
S3	55	F	S1	70

accomplished by referencing incoming labels to the LIB in order to get the value of the outgoing label and the outgoing interface. The packets arriving on interface S2 with label value 60 will be forwarded on interface S0 with outgoing label 20. Similarly, the packets arriving on interface S3 with label value 55 will be forwarded on interface S1 with outgoing label value 70.

III. MPLS COMPONENTS

A. Forwarding Equivalence Class (FEC)

A FEC is a set of packets that are forwarded in the same way through a network. A FEC can include all packets whose destination address matches a particular IP network prefix, or

packets that belong to a particular application between a source and destination computer. FECs are usually built through information learned through an IGP, such as OSPF or RIP [6]. When a packet enters into an MPLS network, the MPLS edge router classifies the packet as part of a particular Forwarding Equivalency Class. Based on the information gleaned from the packet such as source or destination address, the physical interface the packet arrived on, Quality of Service requirements, etc, these groups of packets are forwarded through the MPLS network over the same path with the same treatment.

B. Label

Label is a short, fixed-length, physically contiguous identifier which is used to identify a FEC. It contains all the information needed to forward the packet. The labels are created and assigned to IP packets based upon the information gathered from existing IP routing protocols. Ethernet technologies use what is called a shim label as shown in Fig. 4. The shim label is a 32-bit, locally significant identifier used to identify a FEC. The 32-bit shim header contains the following fields [2]:

- Label (20)—A locally significant ID used to represent a particular FEC during the forwarding process.
- Exp or CoS (3) — Class of service (CoS), Also called experimental range and considered for QoS implementations.

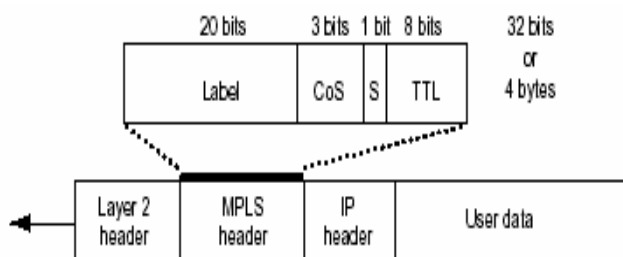

Fig. 4 Label structure

- S (1)— Used to signify if label stack is present. If the label is the only one present or at the bottom of the stack, the bit will be a value of zero.
- TTL (8)—Field used to signify the number of MPLS nodes that a packet has traversed to reach its destination. The value is copied from the packet header and copied back to the IP packet header when it emerges from the Label Switched Path.

When an IP packet is presented to the LER, it pushes the shim header between layers 2 and 3 headers. The shim header is neither a part of layer 2 or layer 3 but it provides a means to relate both layer 2 and layer 3 information. MPLS uses the control-driven model to initiate the assignment and distribution of label bindings i.e. labels are assigned in response to the normal processing of routing protocol traffic, control traffic, or in response to static configuration. The

MPLS control component centers around IP functionality with new standard-based IP signaling and label distribution protocols, as well as extensions to existing protocols. The forwarding component is based on the label-swapping algorithm.

C. Label Edge Router (LER):

A Router sits at the edge of an MPLS domain and is capable of utilizing the routing information to assign labels to packets and then forward them into an MPLS domain.

D. Label Switching Router (LSR)

A Router that typically resides somewhere in the middle of a network and is capable of forwarding packets based upon a label.

E. Label Switch Path

The path followed by a packet in the MPLS domain. It represents a set of routers that the packet has traversed.

F. Label Stack

By placing multiple labels onto a packet, MPLS can support a hierarchical routing design. The set of labels attached to a packet is called the label stack. As the packet traverses the network, only the topmost label is swapped. The labels are organized in a last-in, first-out manner. In other words, the topmost label signifies the highest LSP, and each successive label signifies the next lowest LSP [2].

IV. ADVANTAGES OF MPLS OVER IP

In MPLS, the assignment of a particular packet to a particular FEC is done just once, when the packet enters the network. The FEC to which the packet is assigned is encoded as a "label". The packets are "labeled" before they are forwarded. At subsequent hops, there is no further analysis of the packet's network layer header. This has a number of advantages over conventional network layer forwarding [1].

- MPLS forwarding can be done by switches which are capable of doing label lookup and replacement, but are either not capable of analyzing the network layer headers, or are not capable of analyzing the network layer headers at adequate speed.
- MPLS reduces router processing requirements, since routers simply forward packets based on fixed labels.
- Since a packet is assigned to a FEC when it enters the network, the ingress router may use, in determining the assignment, any information it has about the packet, even if that information cannot be determined from the network layer header. For example, packets arriving on different ports may be assigned to different FECs. Conventional forwarding, on the other hand, can only consider information which travels with the packet in the packet header.
- A packet that enters the network at a particular router can be labeled differently than the same packet entering the network at a different router, and as a result forwarding decisions that depend on the

ingress router can be easily made. This cannot be done with conventional forwarding, since the identity of a packet's ingress router does not travel with the packet.

- Sometimes it is desirable to force a packet to follow a particular route which is explicitly chosen at or before the time the packet enters the network, rather than being chosen by the normal dynamic routing algorithm as the packet travels through the network. This may be done to support traffic engineering. In conventional forwarding, this requires the packet to carry an encoding of its route along with it ("source routing"). In MPLS, a label can be used to represent the route, so that the identity of the explicit route need not be carried with the packet.
- MPLS enables traffic engineering. Explicit traffic routing and engineering help squeeze more data into available bandwidth.
- MPLS supports the delivery of services with Quality of Service (QoS) guarantees. Packets can be marked for high quality, enabling providers to maintain a specified low end-to-end latency for voice and video.
- MPLS Virtual Private Networks scale better than customer-based VPNs since they are provider-network-based, reducing the configuration and management requirements for the customer.

V. IMPLEMENTATION DETAILS

MPLS datapath is implemented as shown in Fig. 5. It communicates with IP and Emac Driver Interfaces. It receives packets from emac driver and checks the protocol type whether the incoming packet is an IP packet or MPLS packet. It refers Label switching Information base (Forwarding Equivalence Class table, Incoming Label Map and Next Hop Label Forwarding Entry Table) and decides the Label operation to be performed according to the configuration of Emac interfaces. Each interface can be configured for the following operation:

- 1: INGRESS
- 2: EGRESS
- 3: LSR
- 4: LSR+INGRESS
- 5: EGRESS+LSR
- 6: INGRESS+LSR+EGRESS

The captured packet is sent to "IP" module for IP routing if a match is not found in the above mentioned tables. Otherwise the Label operation (push/pop/swap) is performed on the packet. The size of the packet is checked considering the

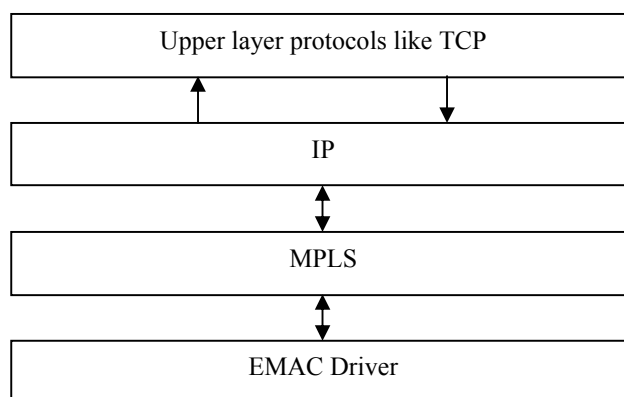

Fig. 5 MPLS Layer

maximum transmission unit of the outgoing interface. If necessary the packet is sent to "IP" module for fragmentation. Here the packets are fragmented and sent back to MPLS again.

VI. DATA STRUCTURES USED

A. Label Type

It is a data structure used to store MPLS label, experimental bits (used for QoS), bottom of stack and time to live for the packet.

B. 32 byte Hardware Area

This structure is used between EMAC driver and MPLS for communication. After, allocating memory for the frame, the EMAC driver fills the 32-byte area with the information for the IP devices to process the packet. Similarly, the MPLS datapath after writing the necessary information in the 32-byte area of the packet, sends it to the EMAC device for transmission. The data structure holds following information of packet:

Interface number on which frame is received or is to be sent, encapsulation type (Ethernet or IEEE 802.3), protocol (IP or ARP), Destination Mac address, multicast, broadcast, cycle count at arrival, and label information [4].

C. Label MTU Information

This structure is used to store the list of mpls labels, encapsulation type, Interface MTU, Next Hop IP address, label stack depth. This is part of 32 byte hardware area.

D. Next Hop Label Forwarding Entry (NHLFE)

The Next Hop Label Forwarding Entry is used when forwarding a packet. It contains the following information: [1]

- The packet's next hop
- Operation to perform on the packet's label stack like:
 - push label
 - replace the label at the top of the label stack with a specified new label
 - pop the label stack

- The data link encapsulation to use when transmitting the packet
- Outgoing interface for the packet
- Label stack and the depth of this stack

E. Incoming Label Map (ILM)

The Incoming Label Map (ILM) maps each incoming label to a set of NHLFEs. It is used when forwarding packets that arrive as labeled packets. It contains fields like incoming label, incoming interface number, nhlfe entry to be used for forwarding the packet [1].

F. FEC-to-NHLFE Map (FTN)

The FEC-to-NHLFE (FTN) maps each FEC to a set of NHLFEs. It is used when forwarding packets that arrive unlabeled, but that are to be labeled before being forwarded. It contains fields for IP address prefix, interface number, nhlfe entry to be used for forwarding the packet [1].

VII. TEST SETUP

The test setup is as shown in Fig. 5. Ping command is issued from PC1. The packets from PC1 are processed by MPLS router and the MPLS packets received by PC2 are analyzed using the tool ethereal.

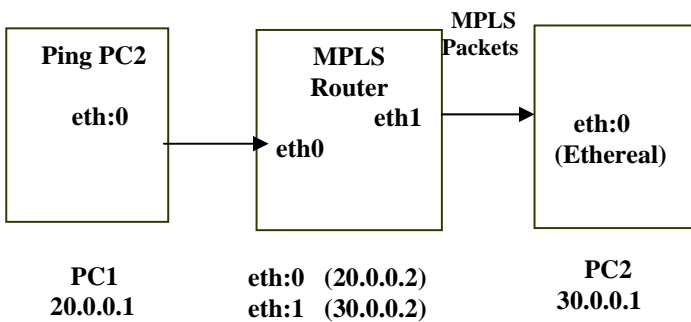

Fig. 6 Test setup

The performance comparison of IP and MPLS is performed for 100 packets without delay (Fig. 7) and with a delay of 100msec (Fig. 8). Packet routing with MPLS is observed to be faster than IP routing.

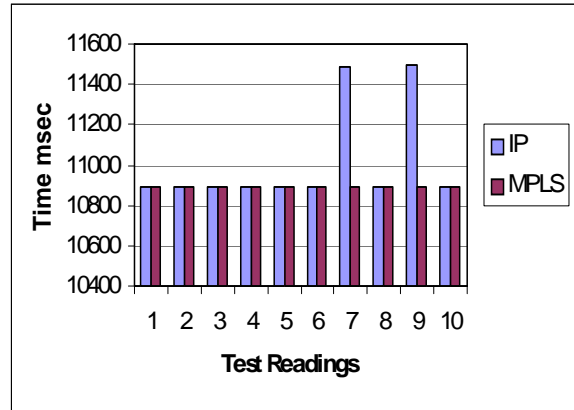

Fig. 8 Test results for 100 packets with 100 msec delay

REFERENCES

- [1] RFC 3031- Multiprotocol Label Switching Architecture.
- [2] RFC 3032 - MPLS Label Stack Encoding.
- [3] MPLS and VPN Architectures -- CCIP Edition Pearson education 2002, Delhi, India.
- [4] TCP/IP Illustrated -- Richard Stevens Volume II Pearson Education 2001, Delhi, India.
- [5] Computer Networks (Fourth edition) -- Andrew S. Tanenbaum. Prentice Hall India, 2002 Delhi, India.
- [6] Routing TCP/IP – Jeff Doyle CCIE #1919 Volume I Techmedia, 2002 Delhi India.

R.N. Pise is working with Vishwakarma Institute of Technology, Pune. She is pursuing her post graduation in Computer Engineering. She is working in the field of Compiler Construction, System Programming, and Computer Networks.

S.A. Kulkarni is presently working as the head, Computer Engineering Department for Post Graduation at Pune Institute of Computer Technology, Pune . He is working in the area of Computer Architecture, Databases and Network security (phone: 91-20-24371101 e-mail: shyamkantk@yahoo.com).

R.V. Pawar is working with Vishwakarma Institute of Technology, Pune. She has a experience of working as Head of Electronics Engineering Department AISSMS Women’s College of Engineering, Pune. She has also worked for INDPRO electronics Pvt. Ltd and handled projects for IFFCO, USHA ISPAT, Reliance and various state electricity boards.

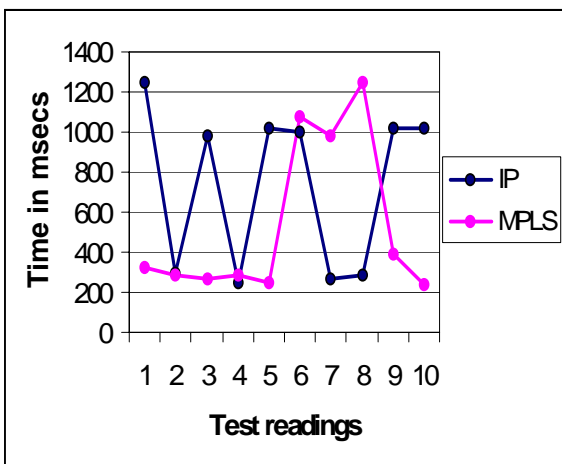

Fig. 7 Test results for 100 packets without delay