

The Auto-Tuning PID Controller for Interacting Water Level Process

Satean Tunyasrirut, Tianchai Suksri, Arjin Numsomran, Supan Gulpanich, and Kittitirasesst

Abstract—This paper presents the approach to design the Auto-Tuning PID controller for interactive Water Level Process using integral step response. The Integral Step Response (ISR) is the method to model a dynamic process which can be done easily, conveniently and very efficiently. Therefore this method is advantage for design the auto tune PID controller. Our scheme uses the root locus technique to design PID controller. In this paper MATLAB is used for modeling and testing of the control system. The experimental results of the interacting water level process can be satisfyingly illustrated the transient response and the steady state response.

Keywords—Coupled-Tank, Interacting water level process, PID Controller, Auto-tuning.

I. INTRODUCTION

IMPORTANTLY, to model the industrial process is necessary to design the linear controller such as PI, PID. There are many methods to model such process for example J.G. Ziegler and N.B. Nichols’s approach [1] as well as K.J Astrom and T. Hugglund’s approach [2] which are famous and better than other techniques. Because of these methods are easy and satisfying to model systems by obtaining the frequency and gain at the critical point of the process. These frequency and gain can be employed to model the process. However, this modeling[2,3] has a divers error with the real process, so that it is bring about designing the better method named Integral System Response (ISR) [4]. The ISR method using the step input signal employs to the process and measures the response from the process for achieving the process parameters.

This paper presents the design of the Auto-Tuning PID controller for interactive Water Level Process by root locus technique and the system modeling can be obtained by integral step response method.

II. THE INTERACTIVE COUPLED-TANK PROCESS

According to Fig. 1, the input u_1 is the input pressure which is taken to the pump, and the output h_2 is the water level in tank 1. The nonlinear equation can be obtained by mass equivalent equation and Bernoulli’s law is given by.

Satean Tunyasrirut, Tianchai Suksri are with Faculty of Engineering, Pathumwan Institute of Technology, Bangkok 10330, Thailand

Arjin Numsomran, Supan Gulpanich and Kittitirasesst are with Faculty of Engineering, King Mongkut’s Institute of Technology Ladkrabang, Bangkok 10520, Thailand (knarjin@kmitl.ac.th).

$$\begin{aligned} \frac{dh_1(t)}{dt} &= -\frac{\beta_{12}a_{12}}{A_1} \sqrt{2g(h_1(t)-h_2(t))} + \frac{k}{A_1} u(t) \\ \frac{dh_2(t)}{dt} &= -\frac{\beta_2 a_2}{A_2} \sqrt{2gh_2(t)} + \frac{\beta_{12}a_{12}}{A_2} \sqrt{2g(h_1(t)-h_2(t))} \end{aligned} \quad (1)$$

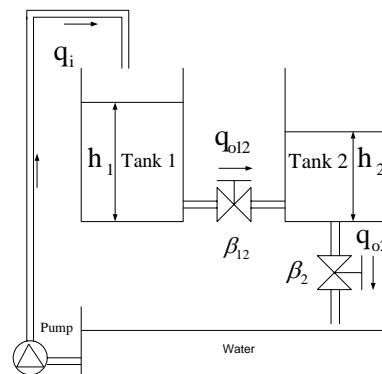

Fig. 1 The interactive coupled-tank process

Where A_1 is the cross section area of tank i (cm^2), a_2 is the cross section area of outlet of tank 2 (cm^2), a_{12} the cross section area of jointed pipe between tank 1 and tank 2 (cm^2), β_2 the value ratio at the outlet of tank 2, β_{12} is the value ratio between tank 1 and tank 2, g is the gravity (cm/s^2) and k is the gain of pump ($cm^3/V \times s$) according to equation 1 is linearized as equation 2.

$$\begin{aligned} \frac{dH_1(t)}{dt} &= \frac{1}{T_{12}} (-H_1(t) + H_2(t)) + \frac{k}{A_1} U(t) \\ \frac{dH_2(t)}{dt} &= -\frac{1}{T_2} H_2(t) + \frac{1}{T_{12}} (H_1(t) - H_2(t)) \end{aligned} \quad (2)$$

Where

$$T_{12} = \frac{A_1}{\beta_{12}a_1} \sqrt{\frac{2(\bar{h}_1 - \bar{h}_2)}{g}}, \text{ s} \quad T_2 = \frac{A_2}{\beta_2 a_2} \sqrt{\frac{2\bar{h}_2}{g}}, \text{ s}$$

\bar{h}_1 and \bar{h}_2 is the water level at operating point of this process, T_{12} is the time constant between tank1 and tank 2 ,and T_2 is the time constant of tank 2 and K . For the equation 2 can be modeled as the equation 3. This is the transfer function for designing this controller.

$$\frac{H_2(s)}{U(s)} = G(s) = \frac{K}{T_{12}T_2s^2 + (T_{12} + 2T_2)s + 1} \quad (3)$$

Where

$$K = \frac{kT_2}{A_2}, \text{ cm/V}$$

III. CONTROL SYSTEM STRUCTURE

The control system structure consists of 3 parts as shown in Fig. 2. The first part is the Interactive coupled-tank process; the second part is to define the mathematic model of the process and the two degree of freedom controller.

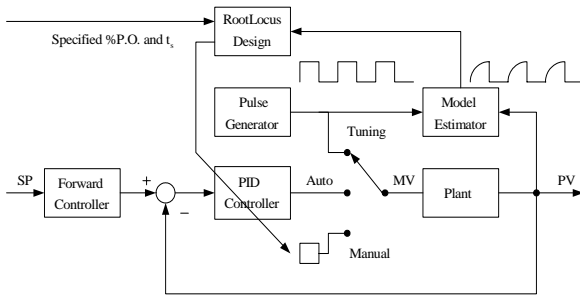

Fig. 2 The control system structure

In the part of modeling system, the Integral System Response (ISR) [4] is used for the Interactive coupled-tank process. According to equation (3), it is able to illustrate the second order system with two poles and without zero thus, the modeling method by ISR will be inputted the step signal for three times.

For the part of two degree of freedom controller is consists of the feedback PID controller and feed forward pre-filter controller. The mathematical model of controller that obtained by ISR is designed the controller by root locus technique. [5]

Feedback controller

$$G_c = \frac{(s + z_{c1})(s + z_{c2})}{s} = \frac{K_d s^2 + K_p s + K_i}{s} \quad (4)$$

Feed forward controller

$$G_f = \frac{z_c}{(s + z_c)} \quad (5)$$

IV. INTEGRAL SYSTEM RESPONSE

The Integral System Response (ISR) [4] is an effective approach to model the industrial process because this method is able to model such process easily, and the achieved model is very close to the actual process. Formulate the transfer function of the process follows as.

$$G(s) = \frac{K_0 \prod_{i=1}^{n-1} (1 + \gamma_i s)}{\prod_{i=1}^n (1 + \tau_i s)} = \frac{K_0 [1 + (\gamma_1 + \gamma_2 + L + \gamma_{n-1})s + L + (\gamma_1 \gamma_2 L \gamma_{n-1})s^{n-1}]}{[1 + (\tau_1 + \tau_2 + L + \tau_n)s + L + (\tau_1 \tau_2 L \tau_n)s^n]} \quad (6)$$

$$= \frac{[K_0 + b_1 s + L + b_{n-1} s^{n-1}]}{[1 + a_1 s + L a_n s^n]}$$

Where

$$b_1 = K_0(\gamma_1 + \gamma_2 + \dots + \gamma_{n-1}) \quad a_1 = (\tau_1 + \tau_2 + \dots + \tau_n)$$

$$\vdots \quad \vdots$$

$$b_{n-1} = K_0(\gamma_1 \gamma_2 \dots \gamma_{n-1}) \quad a_n = (\tau_1 \tau_2 \dots \tau_2)$$

Input the step signal to the process.

$$y_0(t) = \int_0^\infty g(t - \tau)(\tau) d\tau \quad (7)$$

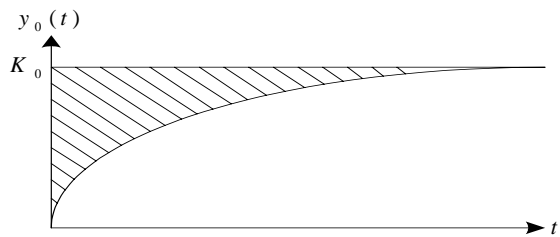

Fig. 3 The process response when inputs step signal in order to define value for K_0

According to Fig. 3, the steady state response can be achieved and the finite state element can be obtained the equation (7) as following.

$$\lim_{t \rightarrow \infty} y_0(t) = \lim_{s \rightarrow 0} s \frac{G(s)}{s} = \lim_{s \rightarrow 0} \frac{[K_0 + b_1 s + \dots + b_{n-1} s^{n-1}]}{[1 + a_1 s + \dots + a_n s^n]} = K_0 \quad (8)$$

Define by

$$y_1(t) = \int_0^\infty [K_0 - y_0(\tau)] d\tau \quad (9)$$

Where $y_1(t)$ is the integral area between K_0 and $y_0(t)$ to take Laplace to equation (9) as.

$$Y_1(s) = \frac{1}{s^2} [K_0 - G(s)] \quad (10)$$

Define by

$$G_1(s) = [K_0 - G(s)] = \frac{(K_0 a_1 - b_1)s + (K_0 a_2 - b_2)s^2 + \dots + K_0 a_n s^n}{1 + a_1 s + \dots + a_n s^n} \quad (11)$$

The finite state element can be obtained the equation (10) as following.

$$\lim_{t \rightarrow \infty} y_1(t) = \lim_{s \rightarrow 0} s \frac{[K_0 - G(s)]}{s^2} = \frac{1}{s} [K_0 - G(s)] = K_0 a_1 - b_1 = K_1 \quad (12)$$

Define by

$$y_2(t) = \int_0^{\infty} [K_1 - y_1(\tau)] d\tau \quad (13)$$

Where $y_2(t)$ is the integral area between K_1 and $y_1(t)$

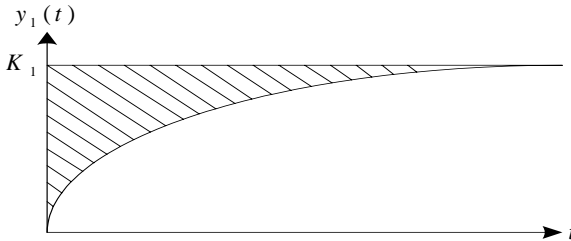

Fig. 4 The process response when inputs step signal in order to define value for K_1

From these equations are able to describe that the high order system must take step signal for many times. The number of taking step input is up to the order of each process which is concluded as the equation below.

$$K_i = K_{i-1}a_1 - K_{i-2}a_2 + K_{i-3}a_3 - \dots + (-1)^{i+1} K_0 a_i + (-1)^i b_i \quad (14)$$

$i = 1, 2, \dots, n$

V. THE ROOT LOCUS TECHNIQUE

To design the controller must be defined the characteristic of transient response and steady state response that can be explained as. [5]

1) The characteristic of transient response can be described in form of percent overshoot (P.O.)

2) The characteristic of steady state response can be described in form of settling time t_s

The method to design for satisfying response at the transient state and steady state can be applied as following steps.

Step 1. Finding the damping ratio: ζ and under damped natural frequency: ω_n by considering the characteristic of transient response and steady state response from the equation (15).

$$P.O. = 100 * e^{\zeta\pi / \sqrt{1-\zeta^2}} \%, \quad t_s^{(\pm 2\%)} = 4 / \zeta\omega_n \quad (15)$$

$$s_d = -\zeta\omega_n \pm j\omega_n\sqrt{1-\zeta^2}$$

Step 2. Finding the summation of angle at s_d of the open loop system $G_c(s)G_p(s)$ by graphical method or arithmetical method and then consider the essential angle of $\angle(s_d + z_c)$ in order to the summation of angle will be being according to the system condition.(16)

$$\sum(\theta_z + \theta_{z_c}) + \sum\theta_p = -(2k+1)\pi, \quad k = 0, 1, \dots, n \quad (16)$$

Step 3. Finding the gain K_c of the controller by using the root locus technique.

$$K_c = K_{sd} = \frac{1}{|G(s_d)H(s_d)|} \quad (17)$$

Step 4. Substitution all of the parameters in the equation of controller.

Step 5. Plot the root locus of $G_c(s)G_p(s)$ in order to confirm that the root locus passes the defined point s_d .

Step 6. To obtain the satisfying response by inputting step signal therefore, adding the feed forward controller as shown in equation (18).

$$G_f(s) = \frac{z_c}{(s + z_c)} \quad (18)$$

VI. EXPERIMENT RESULTS

In this paper MATLAB is used for modeling and testing of the control system. The design of the Auto-Tuning PID controller for interactive Water Level Process by root locus technique and the system modeling can be obtained by integral step response method. The experimental results of the interacting water level process can be illustrated the response of control system and the parameters including the operating point of the process as shown in Table I and Table II.

TABLE I
THE PARAMETERS OF THE PROCESS

$A_1, A_2; cm^2$	$a_2, a_{12}; cm^2$	β_2	β_{12}
66.25	0.1963	0.3	0.56

TABLE II
THE OPERATING POINT OF THE PROCESS

$\bar{h}_1; cm$	$\bar{h}_2; cm$	$\bar{u}; V$	$k; cm^3 / V \cdot s$
9	7	3	2.3

According to the parameters and the operating points of this process can be instead to the equation (3). It will be obtained the transfer function as in equation (19)

$$G(s) = \frac{4.662}{5177s^2 + 307.2s + 1} \quad (19)$$

VII. THE MODELED PROCESS BY USING ISR METHOD

In the part of modeling system, after comparing the achieved model with the non linear process that can be modeled the process following the ISR method. According to equation (3), the Interactive coupled-tank process, is able to illustrate the second order system with two poles and without zero thus, the modeling method by ISR will be inputted the step signal for three times in order to get value of K_0, K_1 and K_2 as shown in figure 5,6 and 7 respectively.

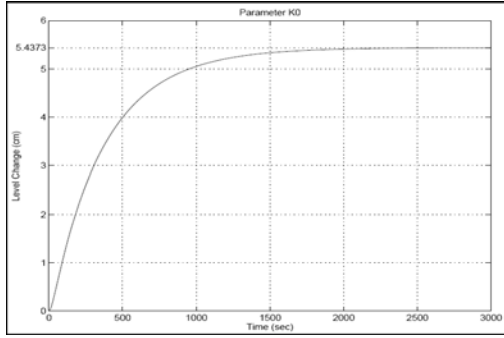

Fig. 5 The process response when inputs step signal for finding K_0

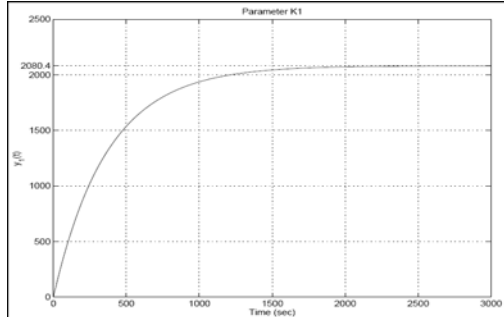

Fig. 6 The process response when inputs step signal for finding K_1

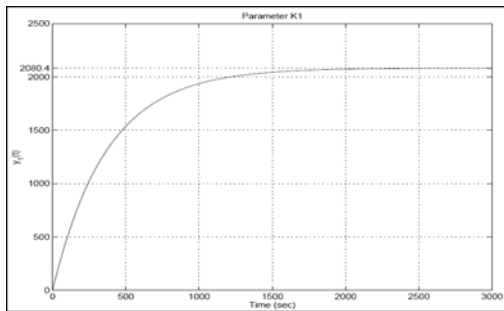

Fig. 7 The process response when inputs step signal for finding K_2

As a result, it will be obtained K_0, K_1 and K_2 as respectively. $K_0 = 5.4373, K_1 = 2080.4$ and $K_2 = 772920$. And then the transfer function can be formulated as following.

$$G(s) = \frac{5.4373}{4243.863s^2 + 382.614s + 1} \quad (20)$$

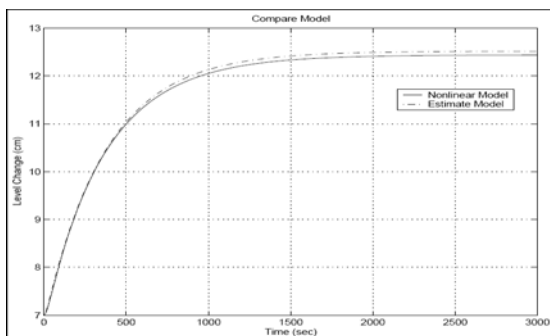

Fig. 8 Comparison the step input response between the modeled system from ISR and nonlinear model

According to Fig. 8, it illustrates the comparison of the step input response between the modeled system from ISR and nonlinear model. In this article, the transient response of the modeled system from ISR is very similar to the modeled system of nonlinear model, but there is some error not more than 5 percent for ISR method.

VIII. THE STEP INPUT RESPONSE

In this topic, The PID controller design by using root locus technique will be explained. The process model which achieved by ISR as the equation (20) is employed to design the controller under this condition.

$$P.O. \leq 5\%, ts^{(\pm 2\%)} \leq 300\text{sec}, e_{ss}(t) = 0$$

From the conditional requirement, it is to be.

$$\zeta = 0.6901, \omega_n = 0.0193, s_d = -0.0133 \pm j0.14$$

And then it is obtained.

$$\theta_c = 81.0484, z_{c1} = 0.0155, z_{c2} = 0.0885, K_c = 18.2115$$

Therefore, the feedback controller and feed forward controller are able to be shown as following.

$$G_c = \frac{18.2115s^2 + 1.8948s + 0.025}{s} \quad G_f = \frac{0.0155}{s + 0.0155}$$

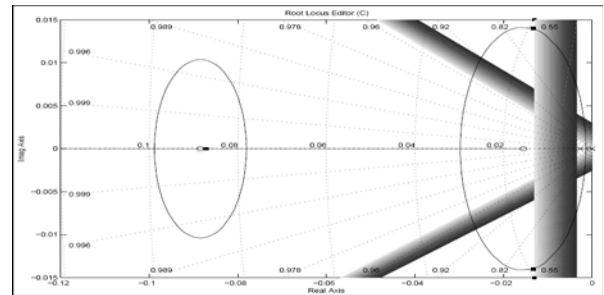

Fig. 9 The root locus of control system

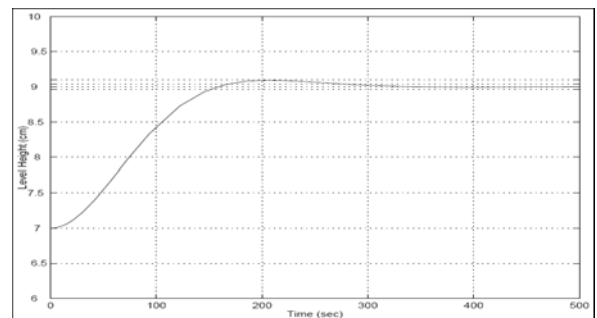

Fig. 10 The step response of control system

As a result, the transient response of the modeled system from ISR has the percent overshoot not more than 5 percent and the setting time is not more than 300 ms. that is under the condition of control system design.

IX. CONCLUSION

This paper presents the design of Auto-tuning PID controller by using Integral System Response method in order to model the process. The interactive Water Level Process used as a case study and the MATLAB is to be a tool for modeling and testing the system. In this article, the transient response of the modeled system from ISR is very similar to the modeled system of nonlinear model, but there is some error not more than 5 percent that is under the condition of control system design.

REFERENCES

- [1] L. Ljung, *System Identification Theory for the User*, Englewood Cliffs, NJ, Prentice-Hall 1987.
- [2] J.G. Ziegler and N.B. Nichols, "Optimum settings for automatic controllers", *Trans. ASME*, vol.65, 1943, pp.433-444.
- [3] K.J. Astrom and T. Hagglund, "Automatic tuning of simple regulators", *Proceeding of IFAC 9th World Conger.*,Budapest, Hungary, 1984, 1867-1872.
- [4] J. Dorsey, *Continuous and Discrete Control Systems*, McGraw Hill, 2002.
- [5] Numsomran A., "2-DOF Control System Designed by Root Locus Technique", *Proceeding of KACC control 15th*,Korea, October 2000.