

Optimal Preventive Maintenance of the Reserve Source in the Industrial Electric Network

M. Bouguerra, H. Meglouli, and I. Habi

Abstract—The great majority of the electric installations belong to the first and second category. In order to ensure a high level of reliability of their electric system feeder, two power supply sources are envisaged, one principal, the other of reserve, generally a cold reserve (electric diesel group).

The principal source being under operation, its control can be ideal and sure, however for the reserve source being in stop, a preventive maintenance's which proceeds on time intervals (periodicity) and for well defined lengths of time are envisaged, so that this source will always available in case of the principal source failure.

The choice of the periodicity of preventive maintenance of the source of reserve influences directly the reliability of the electric feeder system. On the basis of the semi-markovians processes, the influence of the periodicity of the preventive maintenance of the source of reserve is studied and is given the optimal periodicity.

Keywords—Semi Markovians processes, reliability, optimization, electric network.

I. INTRODUCTION

It is known that the electric installations are classified on the basis of several criterions, the principal ones are follows:

- operation mode;
- nature of the current;
- voltage and power level;
- reliability required of their electric feeder system.

According to the last criterion, the electric installations are divided into three categories [1]:

- first category: these installations don't admit any stop (accidental or planned) of their electric feeder system (E.F.S), the stop of the latter can has the human death consequence, this is why their EFS must be carried out with two independent sources.
- Second category: these installations don't admit any stop (accidental or planned) of their electric feeder system (E.F.S), the stop of the latter can has a significant economic consequence, this is why their EFS must be carried out with two independent sources.
- Third category: these installations don't has a capital insert in the technological process, they can admit a stop (accidental or planned) of their EFS going up to 24 hours, their EFS is carried out with only one source.

Authors are with Department of Automation and Electrification of the Industrial Processes, Faculty of Hydrocarbons and Chemistry, University of Boumerdes, Algeria (e-mail: m_ourad59@yahoo.fr).

The great majority of the electric installations belong to the first and second category. In order to ensure a high level of reliability of their electric system feeder, two power supply sources are envisaged, one principal, the other of reserve, generally a cold reserve (electric diesel group) [1]

The principal source being under operation, its control can be ideal and sure, however for the reserve source being in stop, a preventive maintenance's which proceed on time intervals (periodicity) P_m and for well defined lengths of time d_m are envisaged, so that this source will always available in case of the principal source failure.

The choice of the periodicity of preventive maintenance of the source of reserve influences directly the reliability of the electric feeder system. On the basis of the semi-markovians processes, the influence of the periodicity of the preventive maintenance of the source of reserve is studied and is given the optimal periodicity.

II. PRINCIPAL STRUCTURES OF THE EFS OF THE ELECTRIC INSTALLATIONS

According to the critrion of the reliability level required by their EFS, the electric installations belong to the first and second category must has two independent sources, mine source and storing one (Fig. 1).

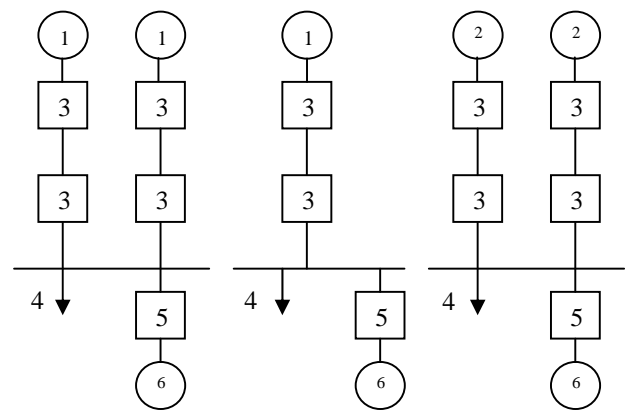

Fig. 1 Standard diagram of the EFS structures

1. external source of the national network
2. local source
3. line circuit breaker
4. electric load
5. coupling circuit breaker
6. reserve source (electric diesel group).

On the basis of these structures, the EFS can be schematised with their reliability parameters as follows (Fig. 2).

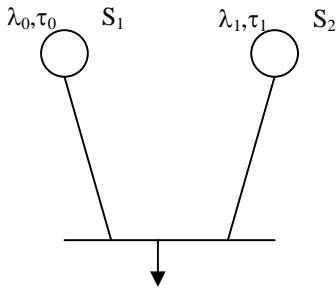

Fig. 2 Representative sources diagram

S_1 : principal source;

S_2 : reserve source;

λ_0, τ_0 : principal source failure rate and time of repair respectively;

λ_1, τ_1 : reserve source failure rate and time of repair respectively.

III. SYSTEM (EFS) STATES AND PROBABILITY OF TRANSITIONS BETWEEN STATES

Under operation, the EFS can has several states, on the basis of the semi-Markovian processes [2,3], the evolution of the EFS operation can be described by the states and the the probability of transitions P_{ij} according to Fig. 3.

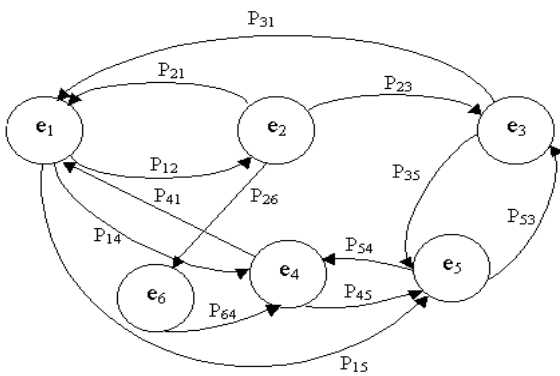

Fig. 3 Semi-Markovian process states and transitions graph

e_1 : PS under operation, RS in reserve;

e_2 : PS under operation, RS in preventive maintenance;

e_3 : PS under operation, RS in repair;

e_4 : RS under operation, PS in repair;

e_5 : PS and RS in repair;

e_6 : SR is started.

PS: principal source, RS: reserve source.

The random values of the good functioning, ξ_0, ξ_1 as well as the repair time η_0, η_1 of the principal source and reserve

source respectively follow an exponential law [4] $P(t)$ and $G(t)$ with the parameters λ_i, μ_i ($i = 0, 1$). The reserve source failure rate is taken equal to $\alpha\lambda_1$ with $0 < \alpha < 1$.

We suppose that the reserve source interlocking in the event of the principal source failure is absolutely reliable, the reserve source starting is immediate.

IV. CALCULATION OF THE TRANSITIONS PROBABILITY BETWEEN STATES

The transitions probability P_{ij} could be calculated as follows:

$$P_{12} = P\{\xi_0 > P_m\} = e^{-\lambda_0 P_m}$$

$$P_{14} = P\{\xi_0 < P_m\} \cdot P\{\xi_1 > P_m\} = (1 - e^{-\lambda_0 P_m}) \cdot e^{-\alpha\lambda_1 P_m}$$

$$P_{15} = P\{\xi_0 < P_m\} \cdot P\{\xi_1 < P_m\} = (1 - e^{-\lambda_0 P_m}) \cdot (1 - e^{-\lambda_1 P_m})$$

$$P_{21} = P\{\xi_1 > P_m\} \cdot P\{\xi_0 > d_m\} = e^{-(\lambda_0 d_m + \alpha\lambda_1 P_m)}$$

$$P_{23} = P\{\xi_1 < P_m\} = (1 - e^{-\alpha\lambda_1 P_m})$$

$$P_{26} = P\{\xi_1 > P_m\} \cdot P\{\xi_0 < d_m\} = e^{-\alpha\lambda_1 P_m} (1 - e^{-\lambda_0 d_m})$$

$$P_{31} = P\{\xi_0 > \eta_1\} = \int_0^{\infty} [1 - P_0(t)] dG_1(t) = \frac{\mu_1}{\lambda_0 + \mu_1}$$

$$P_{35} = P\{\xi_0 < \eta_1\} = \int_0^{\infty} P_0(t) dG_1(t) = \frac{\lambda_0}{\lambda_0 + \mu_1}$$

$$P_{41} = P\{\eta_0 < \xi_1\} = \int_0^{\infty} G_0(t) dP_1(t) = \frac{\mu_0}{\mu_0 + \alpha\lambda_1}$$

$$P_{45} = P\{\eta_0 > \xi_1\} = \int_0^{\infty} [1 - G_0(t)] dP_1(t) = \frac{\alpha\lambda_1}{\mu_0 + \alpha\lambda_1}$$

$$P_{53} = P\{\eta_0 < \eta_1\} = \int_0^{\infty} G_0(t) dG_1(t) = \frac{\mu_0}{\mu_0 + \mu_1}$$

$$P_{54} = P\{\eta_1 < \eta_0\} = \int_0^{\infty} G_1(t) dG_0(t) = \frac{\mu_1}{\mu_0 + \mu_1}$$

$$P_{64} = 1$$

where:

P_m : periodicity of preventive maintenance of the source of reserve;

d_m : time duration of the preventive maintenance;

P : probability;

λ_0, λ_1 : failure rate of the principal and reserve source respectively;

μ_0, μ_1 , repair rate of the principal and reserve source respectively,

ξ_0, ξ_1 : random time of good functioning of the principal and reserve source respectively,

η_0, η_1 : repair random time of the principal and reserve source respectively,

$P_0(t), P_1(t)$: failure law distribution of the principal and reserve source respectively,

$G_0(t), G_1(t)$: repair law distribution of the principal and reserve source respectively.

V. CALCULATION OF THE TIME OF OCCUPATION AT STATE E_i

The average time T_{e_i} of occupation at state e_i could be calculated as follows:

$$T_{e_1} = E \min\{\xi_0, P_m\} = \int_0^{P_m} [1 - P_0(t)] dt = \frac{1 - e^{-\lambda_0 P_m}}{\lambda_0}$$

$$T_{e_2} = E \min\{\xi_0, d_m\} = \int_0^{d_m} [1 - P_0(t)] dt = \frac{1 - e^{-\lambda_0 d_m}}{\lambda_0}$$

$T_{e_6} = 0$ (the reserve source starting is immediate)

where:

E: expected valued.

For the other states, knowing the existence distribution law $T_{ij}(t)$ in the state e_i at the time of the transition to the state e_j , we determine the law of distribution $F_i(t)$ and the existence mean time at the state e_i , T_{e_i} as follows:

$$F_i(t) = \sum_{j=0}^n P_{ij} T_{ij}(t)$$

$$T_{e_i} = \int_0^{\infty} t dF_i(t)$$

where:

$$T_{31}(t) = P\{\eta_1 < t / \eta_1 < \xi_0\} = 1 - e^{-(\mu_1 + \lambda_0)t}$$

$$T_{35}(t) = P\{\xi_0 < t / \eta_1 > \xi_0\} = 1 - e^{-(\mu_1 + \lambda_0)t}$$

$$T_{41}(t) = P\{\eta_0 < t / \eta_0 < \xi_1\} = 1 - e^{-(\mu_0 + \alpha\lambda_1)t}$$

$$T_{45}(t) = P\{\xi_1 < t / \eta_0 > \xi_1\} = 1 - e^{-(\mu_0 + \alpha\lambda_1)t}$$

$$T_{53}(t) = P\{\eta_0 < t / \eta_0 < \eta_1\} = 1 - e^{-(\mu_0 + \mu_1)t}$$

$$T_{54}(t) = P\{\eta_1 < t / \eta_1 < \eta_0\} = 1 - e^{-(\mu_0 + \mu_1)t}$$

we determine that:

$$T_{e3} = \frac{1}{\mu_1 + \lambda_0}, T_{e4} = \frac{1}{\mu_1 + \alpha\lambda_1}, T_{e5} = \frac{1}{\mu_1 + \mu_0}$$

VI. CALCULATION OF THE STATIONNARY PROBABILITY OF OCCUPATION AT STATE E_i

The stationary probabilities P_i of occupation at the state e_i can be given by solving the equations system [3] according t

$$P_i = \sum_{j \in e} P_{ij} \cdot P_j$$

$$\sum_{i=1}^6 P_i = 1$$

$$P_1 = P_{21} \cdot P_2 + P_{31} \cdot P_3 + P_{41} \cdot P_4$$

$$P_2 = P_{12} \cdot P_1$$

$$P_3 = P_{23} \cdot P_2 + P_{53} \cdot P_5$$

$$P_4 = P_{14} \cdot P_1 + P_{54} \cdot P_5 + P_{64} \cdot P_6$$

$$P_5 = P_{15} \cdot P_1 + P_{35} \cdot P_3 + P_{45} \cdot P_4$$

$$P_6 = P_{26} \cdot P_2$$

VII. CALCULATION OF THE MEAN TIME BETWEEN FAILURES

The mean time between failures system (EFS) can be obtained as follows: [3]

$$T_f = \frac{\sum_{e_n \in e^+} P_{e_n} \cdot T_{e_n}}{\sum_{i \in e^+, j \in e^-} P_i \cdot P_{ij}}$$

where:

P_{e_n} : stationnary probability at state e_n

T_{e_n} : average time of occupation at state e_n

e^+ : states of good functioning of system

e^- : failure's states of system.

VIII. APPLICATION OF THE METHOD

The method is applied to an electric feeder system with two independent sources, a principal source, the second of reserve and having the following reliability parameters:

$\lambda_0 = 0.4$ [1/year]; $\lambda_1 = 5$ [1/year]; $\tau_0 = 50$ h,

$\tau_1 = 100$ h, $d_m = 8$ h.

T the mean time between failures variation curve obtained a according to the ratio P_m/d_m is as follows (Fig. 4):

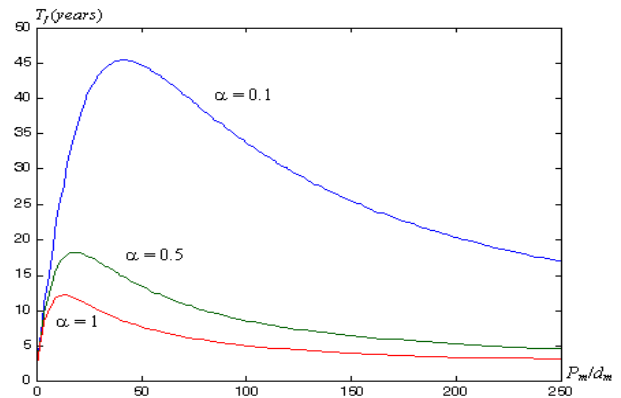

Fig. 4 Mean time between failures variation

IX. CONCLUSION

- An optimal periodicity of preventive maintenance of the reserve source has been found which corresponds to the maximum time between failures of the system.
- An optimal periodicity of preventive maintenance of the source of reserve can be explained as follows: a great periodicity of preventive maintenance of the source of reserve has a consequence a great probability of having a failure of this source; so we have a reduction in the mean time between failures, for a weak periodicity the probability to have a failure of the principal source during a preventive maintenance of the source of reserve is significant; so we have a reduction of the mean time between failures of the system.

REFERENCES

- [1] Bouguerra M. Analyse des variantes des reseaux electriques des stations de compression de gaz , Viniti, n°9 , p109 – 111, moscou - russie, 1987.
- [2] Kaufman A. , Grouchy D., Druon R. Modeles mathematiques pour l'étude de la fiabilité des systemes.Masson et Cie, 1975.
- [3] Korolok V.S., Tourbine A.F. Processus semi markoviens et leur application, doumka, Kiev, 1976.
- [4] Bouguerra M., Benouareth A., "*Optimal Rebulding of the Electric Feeder Systems of the Gas Compressors Plants in Algeria*", ICEEC'04.Proceeding of the IEEE catalog number : 04EX893C, ISBN : 0-7803-8576 , Cairo, P 849 – 851, 2004.