

# Optimal Sizing of SSSC Controllers to Minimize Transmission Loss and a Novel Model of SSSC to Study Transient Response

A. M. El-Zonkoly

**Abstract**—In this paper, based on steady-state models of Flexible AC Transmission System (FACTS) devices, the sizing of static synchronous series compensator (SSSC) controllers in transmission network is formed as an optimization problem. The objective of this problem is to reduce the transmission losses in the network. The optimization problem is solved using particle swarm optimization (PSO) technique. The Newton-Raphson load flow algorithm is modified to consider the insertion of the SSSC devices in the network. A numerical example, illustrating the effectiveness of the proposed algorithm, is introduced. In addition, a novel model of a 3-phase voltage source converter (VSC) that is suitable for series connected FACTS a controller is introduced. The model is verified by simulation using Power System Blockset (PSB) and Simulink software.

**Keywords**—FACTS, Modeling, PSO, SSSC, Transmission loss reduction.

## I. INTRODUCTION

IN today's highly complex and interconnected power systems, there is a great need to improve electric power utilization while still maintaining reliability and security. While power flows in some of the transmission lines are well below their normal limits, other lines are overloaded, which has an overall effect on deteriorating voltage profiles and decreasing system stability and security. Because of all that, it becomes more important to control the power flow along the transmission lines to meet the needs of power transfer. On the other hand, the fast development of solid-state technology has introduced a series of power electronic devices that made FACTS a promising pattern of future power systems.

Power flow is a function of transmission line impedance, the magnitude of the sending end and receiving end voltages and the phase angle between voltages. By controlling one or a combination of the power flow arrangements, it is possible to control the active, as well as, the reactive power flow in the transmission line [1].

With FACTS technology, such as Static Var Compensators (SVCs), Static Synchronous Compensators (STATCOMs), Static Synchronous Series Compensators (SSSCs) and

Unified Power Flow Controller (UPFC), etc., bus voltages, line impedances and phase angles in the power system can be regulated rapidly and flexibly. Thus, FACTS can facilitate the power flow control, enhance the power transfer capability, decrease the generation cost, and improve the security and stability of the power system. In previous work, researches concentrated on locating and sizing of different types of FACTS devices in order to maximize the power transfer considering networks with variable loads. The problem was formulated as an optimization problem and was solved using different methods such as using iterative techniques, MATLAB optimization routines or Genetic Algorithm (GA) [2-4].

In this paper, the problem of sizing of SSSC controllers is formulated as an optimization problem with the objective of minimizing the transmission losses in a network with unchanged loads. The problem is solved using PSO method, which is fast and simple if compared with GA technique and also give promising results. In order to calculate the power losses and check the system operating constraints such as voltage profile, a load flow model is used. A modified load flow model, based on the existing Newton-Raphson load flow algorithm, is introduced in [5]. That model was modified to represent the UPFC devices. In this paper, this model is further modified in order to include the SSSC devices presented into the network. The proposed algorithm is tested using the IEEE 14 bus system at different levels of loading and the results are presented.

Further more, to have the ability to study the transient response of an SSSC device under different operating conditions of the power system, a novel model of SSSC controller is proposed. The model was simulated using PSB and Simulink software. A small, two-area test system is used to verify the validity of the proposed model.

## II. OPTIMAL SIZING OF SSSC DEVICES BASED ON PSO

### A. Static Synchronous Series Compensator (SSSC)

The SSSC is one of the most recent FACTS devices for power transmission series compensation. It can be considered as a synchronous voltage source as it can inject an almost sinusoidal voltage of variable and controllable amplitude and phase angle, in series with a transmission line. The injected voltage is almost in quadrature with the line current. A small part of the injected voltage that is in phase with the line

Manuscript was submitted October 12, 2006.

A. M. El-Zonkoly is with the Electrical Engineering Department, Arab Academy for Science & Technology, Alexandria, Egypt (e-mail: amanyelz@yahoo.com).

current provides the losses in the inverter. Most of the injected voltage, which is in quadrature with the line current, provides the effect of inserting an inductive or capacitive reactance in series with the transmission line. This variable reactance influences the electric power flow in the transmission line. The theory of operation of SSSC and its control fundamentals are presented extensively in literature [6-10]. Fig. 1 shows the basic diagram of the SSSC and its equivalent representation.

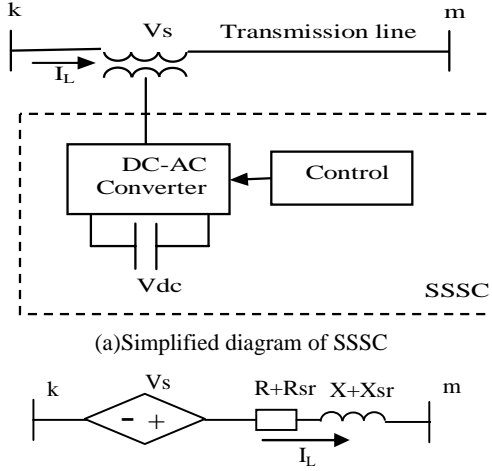

(b) Model of transmission line m-k installed with SSSC device

Fig. 1 Basic diagram of the SSSC and its equivalent representation

Where

$R, X$  the transmission line resistance and inductive reactance, respectively.

$V_s$  the SSSC injected voltage.

$I_L$  the line current.

$R_{sr}, X_{sr}$  the resistance and inductive reactance of the series source, respectively.

### B. Load Flow Model

An attractive, Newton-Raphson based, load flow algorithm for modeling UPFC devices has been developed in [5]. Based on that algorithm, some modifications are done to model the SSSC devices as a voltage source with known amplitude and phase angle in series with transmission line.

First, the admittance matrix of the system is modified to include the series source impedance. This is done by changing the line impedance between bus  $k$  and bus  $m$  such that

$$Z_{km} = (R_{km} + R_{sr}) + j(X_{km} + X_{sr}) \quad (1)$$

and hence,

$$Y_{km} = \frac{1}{Z_{km}} = G_{km} + jB_{km} \quad (2)$$

The linearized power flow equations and the system Jacobian will be modified such that

$$[f(x)] = [J][\Delta x] \quad (3)$$

where

$$[f(x)] = [\Delta P^k \ \Delta P^m \ \Delta Q^k \ \Delta Q^m]^T \quad (4)$$

$$[\Delta x] = [\Delta \theta_k \ \Delta \theta_m \ \frac{\Delta V_k}{V_k} \ \frac{\Delta V_m}{V_m}]^T \quad (5)$$

$$[J] = \begin{bmatrix} H_{kk} & H_{km} & N_{kk} & N_{km} \\ H_{mk} & H_{mm} & N_{mk} & N_{mm} \\ J_{kk} & J_{km} & L_{kk} & L_{km} \\ J_{mk} & J_{mm} & L_{mk} & L_{mm} \end{bmatrix} \quad (6)$$

The Jacobian terms in (6) are given in Appendix A.

### C. Problem Formulation as an Optimization Problem

The power flow control in interconnected system with several SSSC devices installed is of great importance. For a fixed loads power systems the main objective is to minimize the transmission loss in the system and, in the same time, keep the voltage profile within acceptable limits. The objective function and the corresponding constraints of this problem can be represented by (7)-(11), respectively.

$$\text{Min } F = \sum_{l=1}^{nl} P_l \quad (7)$$

Subjected to

$$V_{\min} \leq V_i \leq V_{\max} \quad (8)$$

$$I_{ij \min} \leq I_{ij} \leq I_{ij \max} \quad (9)$$

$$V_{si \min} \leq V_{si} \leq V_{si \max} \quad (10)$$

$$(\text{capacitive}) -\Pi/2 \leq \gamma_{si} \leq \Pi/2 (\text{inductive}) \quad (11)$$

where

$F$  the objective function to be minimized.

$P_l$  the power loss in line number  $l$ .

$nl$  the number of transmission lines in the network.

$V_i$  the voltage magnitude at node  $i$ .

$I_{ij}$  the magnitude of  $i$ - $j$  branch current.

$V_{si}$  the magnitude of the  $i^{\text{th}}$  series voltage source.

$\gamma_{si}$  the phase angle of the  $i^{\text{th}}$  series voltage source w.r.t. the line current.

The control parameters that to be determined optimally are the magnitudes and phase angles of the installed SSSC devices.

### D. Problem Solution Using PSO Method

PSO is one of the optimization techniques and belongs to evolutionary computation techniques [11-13]. The method has been developed through a simulation of simplified social models.

PSO is basically developed through simulation of bird flocking in two-dimension space. The position of each individual (agent) is represented by XY axis position and also the velocity is expressed by  $v_x$  (the velocity of X axis) and  $v_y$  (the velocity of Y axis). Modification of the agent position is realized by the position and velocity information.

An optimization technique based on the above concept can be described as follows: namely, bird flocking optimizes a certain objective function. Each agent knows its best value so far (pbest) and its XY position. Moreover, each agent knows the best value so far in the group (gbest) among pbests. Each agent tries to modify its position. This modification can be represented by the concept of velocity. Velocity of each agent can be modified by the following equation:

$$V_i^{k+1} = wV_i^k + c_1 \text{rand} \times (pbest_i - S_i^k) + c_2 \text{rand} \times (gbest - S_i^k) \quad (12)$$

where,

- w : weighting function,
- c<sub>j</sub> : weighting factor,
- rand : random number between 0 and 1,
- s<sub>i</sub><sup>k</sup> : current position of agent i at iteration k,
- pbest<sub>i</sub> : pbest of agent i,
- gbest : gbest of group.

Using the above equation, a certain velocity, which gradually gets close to pbest and gbest can be calculated. The current position (searching point in the solution space) can be modified by the following equation:

$$S_i^{k+1} = S_i^k + V_i^{k+1} \quad (13)$$

The proposed algorithm will proceed as follows:

1. Input the system data.
2. Initialize the swarm with random positions and velocities.
3. Evaluate the fitness of each particle (objective value) as described by Eq.(7).
4. Determine the personal and global best positions.
5. Update the velocity of agents using Eq.(12).
6. Update the position of agents using Eq.(13).
7. Perform the position check (the boundaries of each parameter). If violated then repair the algorithm then go to step 8. If not violated go to step 8.
8. Check the stopping criterion. If met go to step 9 and if not met go back to step 3.
9. Output the optimal solution, which are the optimal values of the control parameters of each SSSC device.

### III. MATH

If To verify the effectiveness of the proposed algorithm, it is applied to the IEEE 14 bus test system. As given in [4], the SSSC devices will be installed on line 2-4, 10-11 and 12-13.

TABLE I  
THE POWER DEMAND AND THE SYSTEM TRANSMISSION LOSS

Bus no.	Power demand (MW)	
	Case 1	Case2
1	0	0
2	21.7	30
3	94.2	94.2
4	47.6	50.6
5	7	19.6

6	11	35.2
7	0	0
8	0	0
9	29.5	35.5
10	9	29
11	3.5	5.5
12	6.1	35.1
13	13.5	15.5
14	14.9	14.9
Total demand (MW)	258.8	365.1
Ploss (MW)	22.926	49.185

: velocity of agent i at iteration k,

The PSO parameters were selected such that

Maximum iterations = 20      Swarm size = 10

and the control parameters boundaries are

V<sub>s</sub> = [0 0.15] pu      γ<sub>s</sub> = [0 90] deg.

The system is tested under two levels of demand power. The power demand and the system transmission loss during the two operating conditions, without SSSC devices installed, are given in Table I.

#### A. Case Study 1

Under the first operating conditions, the PSO algorithm is applied and the results are given in Table II.

TABLE II  
THE CONTROL PARAMETERS RESULTED FOR CASE STUDY 1

Line	2-4	10-11	12-13
V <sub>s</sub> (PU)	0.15	0.01	0.15
γ <sub>s</sub> (Deg)	90	86	90

The total power loss of the system is reduced to 9.018 MW, i.e. reduced by approximately 60%. The voltage profiles of the system with and without the SSSC devices are shown in Fig. 4. As shown in the figure, the voltage is improved at some buses. Fig. 5 shows the convergence process of the objective function through the iterations.

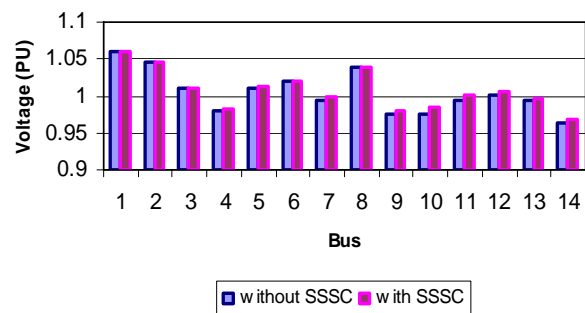

Fig. 4 The voltage profile of the IEEE 14 bus system for case 1

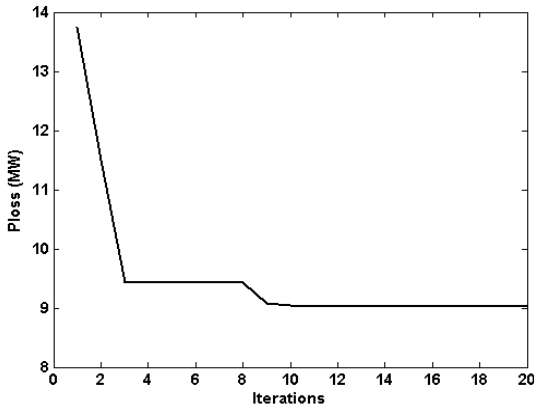

Fig. 5 Conversion process of objective function through the iterations

**B. Case Study 2**

In this case, the total power demand of the system is increased by approximately 40%. Under this condition, the results of the PSO algorithm is given in Table III.

TABLE III  
THE CONTROL PARAMETERS RESULTED FOR CASE STUDY 2

Line	2-4	10-11	12-13
$V_s$ (PU)	0.15	0.01	0.15
$\gamma_s$ (Deg)	90	85	88

The power loss was reduced to 17.903 MW, i.e. reduced by approximately 64%. The voltage profiles of the system with and without the SSSC devices are shown in Fig. 6. As shown in the figure, the voltages at bus 4 and bus 14 were out of acceptable limits (<0.95PU) and improved with the SSSC devices installed. Fig. 7 shows the convergence process of the objective function through the iterations.

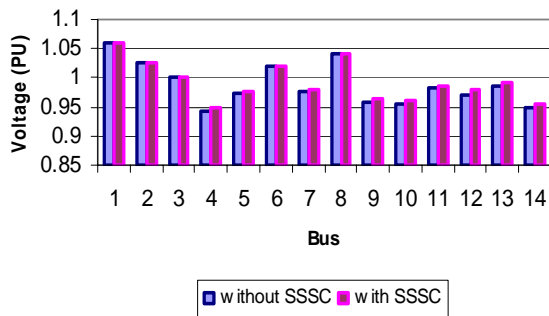

Fig. 6 The voltage profile of the IEEE 14 bus system for case 2

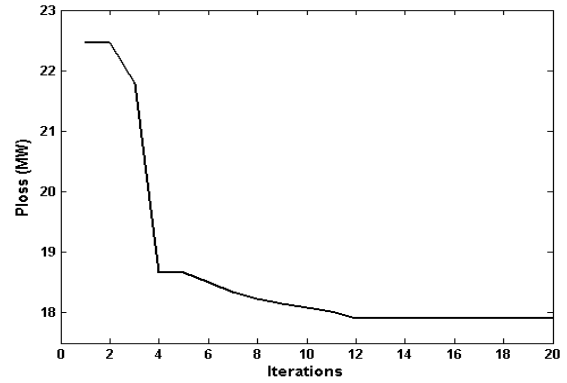

Fig. 7 Conversion process of objective function through the iterations

**IV. SOME COMMON MISTAKES**

In order to study the dynamic performance and transient stability of power system equipped with SSSC controllers, several models in the time domain and in the frequency domain in addition to several control algorithms were developed and tested [7-10, 14].

In this paper, a new model of the 3-phase VSC that is suitable for series connected FACTS controllers is proposed. The primary function of the SSSC is to control the power flow in the transmission line. This objective can be achieved either by direct control of the line current or by the indirect control of either the compensating reactance  $X_q$  ( $X_q$ -control) or the component of the  $V_s$  that is in quadrature to the line current ( $V_q$ -control) [14]. In this paper, the  $V_q$ -control is applied with some modification.

In the proposed model, the angle of the injected voltage ( $\alpha$ ) is controlled according to the difference between the actual injected voltage magnitude and its reference value and according to the sign of the reference value. The sign will be positive for capacitive operation and negative for inductive operation. On the other hand, the traditional capacitor in the DC side of the VSC is replaced by a current-reactance controlled DC voltage source. The DC voltage magnitude is determined according to the normalized values of the line current and the injected reactance with respect to their values under normal conditions. During normal operation with normal current flow and normal value of injected reactance, the DC voltage magnitude is nominal. With the change in current and injected reactance, the DC voltage magnitude change with the same ratios.

The digital simulation is accomplished by using the PSB and the Simulink software. The test system is shown in Fig. 8 and its data are given in Appendix B. The control block diagram proposed for the SSSC is shown in Fig. 9.

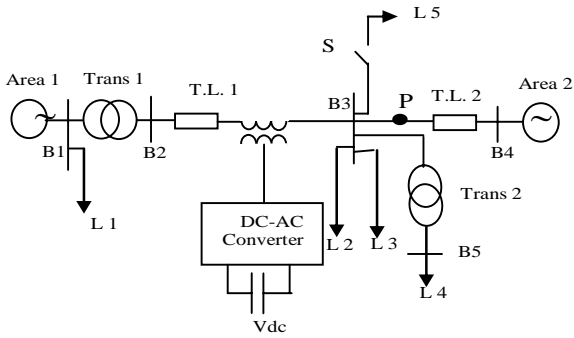

Fig. 8 Single line diagram of the test system

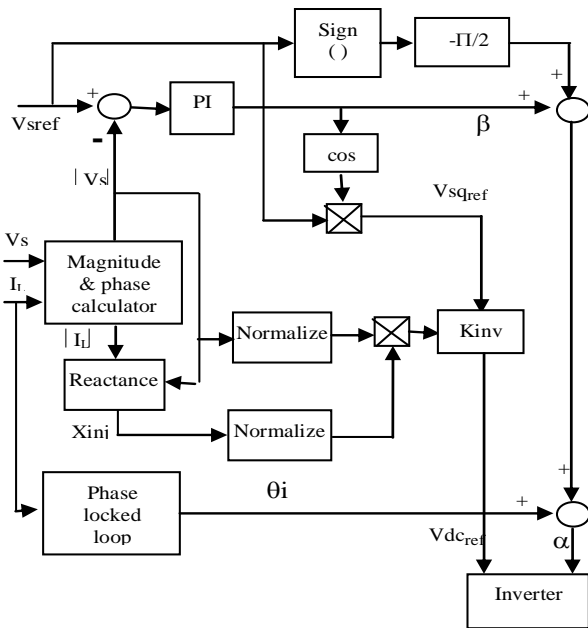

Fig. 9 Control block diagram of SSSC

V. SIMULATION RESULTS

The controller is designed to inject a maximum voltage of 0.2 PU. The three test conditions considered in [14] are considered in this paper to be able to compare the response of the proposed model and the response of the model presented in [14] using the EMTP-RV program.

A. Case1: Impact of Step Change of Reference Value

The dynamic behavior of the proposed controller is verified by changing the reference value of the injected voltage from 0.1 PU to 0.12 PU at time  $t=400$  ms till 600ms. The response is shown in Fig. 10.

- a) This shows the injected reactance in the transmission line in PU, which increased with the increase of the reference value of the injected voltage.
- b) This shows the corresponding increase of the DC side voltage in PU.

- c) This shows RMS value of 3 phase transmission lines current in PU.
- d) This shows the phase angle between injected voltage and transmission line current in Deg.
- e) This shows Injected reactive power to transmission line in PU.

The proposed model responded to the change in the same manner as the model in [14].

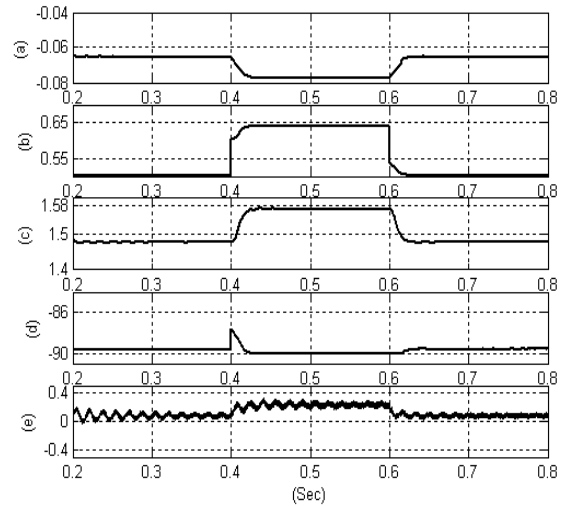

Fig. 10 System response to step change in controller reference value

B. Case2: Impact of Load Variation

The dynamic behavior of the SSSC controller is verified by an increase in the system load. That increase is accomplished by closing the breaker S to connect a load of 300MW to bus B3 at time  $t=400$ ms till 600ms. The response of the system is shown in Fig. 11.

- a) This shows the injected reactance in the transmission line in PU, which slightly decreased with the increase of the system load.
- b) This shows the increase of the DC side voltage in PU to provide the required injected voltage and hence reactance.
- c) This shows RMS value of 3 phase transmission lines current in PU.
- d) This shows the phase angle between injected voltage and transmission line current in Deg.
- e) This shows Injected reactive power to transmission line in PU.

Once more, the response of the proposed system and that of [14] agreed.

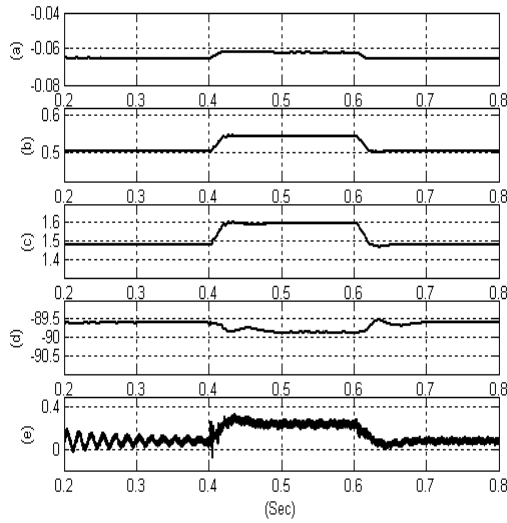

Fig. 11 Impact of load variation

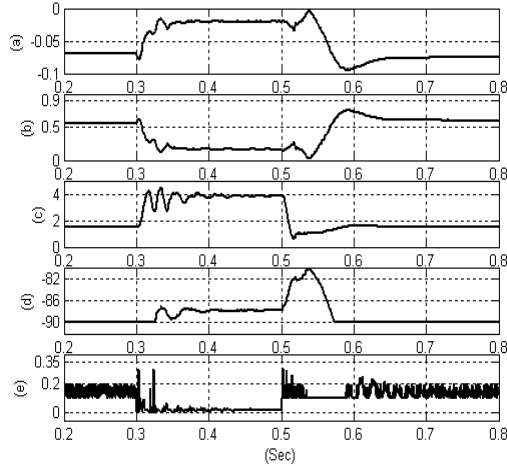

Fig. 12 System response to 3 line to ground fault

### C. Case3: Impact of a Balanced Fault at Point P

In this case, a 3-phase balanced fault is performed at point P at time  $t=300\text{ms}$  till  $500\text{ms}$ . The response is shown in Fig. 12.

- This shows the injected reactance in the transmission line in PU, which very much decreased during the fault.
- This shows the decrease of the DC side voltage in PU to decrease the injected voltage and hence reactance.
- This shows RMS value of 3 phase transmission lines current in PU.
- This shows the phase angle between injected voltage and transmission line current in Deg.
- This shows Injected reactive power to transmission line in PU.

This time the response of the proposed system and that of the system in [14] are approximately the same.

## VI. CONCLUSION

In this paper, the PSO method was applied to optimally determine the magnitude and phase angle of the series injected voltage in transmission line. A Newton-Raphson load flow algorithm was modified to include the SSSC devices in the system analysis. The results showed an improvement in the voltage profile of the system in addition to a great reduction in the system transmission loss. On the other hand, the proposed model of the SSSC controller was validated through applying several testes on it.

## APPENDIX

### JACOBIAN EQUATIONS OF SSSC MODEL

The Jacobian equations at the sending node are,

$$H_{km} = V_k V_m (G_{km} \sin(\theta_k - \theta_m) - B_{km} \cos(\theta_k - \theta_m)) \quad (A.1)$$

$$H_{ksr} = V_k V_s (G_{km} \sin(\theta_k - \theta_s) - B_{km} \cos(\theta_k - \theta_s)) \quad (A.2)$$

$$H_{kk} = -H_{km} - H_{ksr} \quad (A.3)$$

$$N_{km} = V_k V_m (G_{km} \cos(\theta_k - \theta_m) + B_{km} \sin(\theta_k - \theta_m)) \quad (A.4)$$

$$N_{ksr} = V_k V_s (G_{km} \cos(\theta_k - \theta_s) + B_{km} \sin(\theta_k - \theta_s)) \quad (A.5)$$

$$N_{kk} = 2V_k^2 G_{kk} + N_{km} + N_{ksr} \quad (A.6)$$

$$J_{km} = -N_{km} \quad J_{kk} = -N_{km} + N_{ksr} \quad (A.7)$$

$$L_{km} = H_{km} \quad L_{kk} = -2V_k^2 B_{kk} - H_{kk} \quad (A.8)$$

The Jacobian equations at receiving node are,

$$H_{mk} = V_m V_k (G_{mk} \sin(\theta_m - \theta_k) - B_{mk} \cos(\theta_m - \theta_k)) \quad (A.9)$$

$$H_{msr} = V_m V_s (G_{mm} \sin(\theta_m - \theta_s) - B_{mm} \cos(\theta_m - \theta_s)) \quad (A.10)$$

$$H_{mm} = -H_{mk} - H_{msr} \quad (A.11)$$

$$N_{mk} = V_m V_k (G_{mk} \cos(\theta_m - \theta_k) + B_{mk} \sin(\theta_m - \theta_k)) \quad (A.12)$$

$$N_{msr} = V_m V_s (G_{mm} \cos(\theta_m - \theta_s) + B_{mm} \sin(\theta_m - \theta_s)) \quad (A.13)$$

$$N_{mm} = 2V_m^2 G_{mm} + N_{mk} + N_{msr} \quad (A.14)$$

$$J_{mk} = -N_{mk} \quad J_{mm} = N_{mk} + N_{msr} \quad (A.15)$$

$$L_{mk} = H_{mk} \quad L_{mm} = -2V_m^2 B_{mm} - H_{mm} \quad (A.16)$$

## APPENDIX B

### SYSTEM PARAMETERS OF FIG. 8 (BASE MVA = 100)

- Area 1: Rated Voltage: 13.8 kV  
Short Circuit Capacity: 21000 MVA
- Area 2: Rated Voltage: 735 kV  
Short Circuit Capacity: 30000 MVA
- Transformer 1 ( $\Delta/Y$ ): Rated Voltage: 13.8/735 kV  
Rated Power: 2100 MVA  
Leakage Resistance: 0.002 pu  
Leakage Reactance: 0.08 pu
- Transformer 2 ( $Y/Y$ ): Rated Voltage: 735/230 kV  
Rated Power: 300 MVA  
Leakage Resistance: 0.002 pu  
Leakage Reactance: 0.15 pu
- Transmission Lines: Resistance: 0.001 pu  
Reactance: 0.0195 pu
- Loads: Load 1: 100 MW  
Loads 2 and 3: 1.32 MW, 330MVAR  
Load 4: 250MW

Load 5: 300MW

SSSC: Rated Power: 100 MVA  
 Nominal DC Voltage: 20 kV  
 Nominal AC Voltage: 138 kV  
 Number of Pulses: 48 pulse

Coupling Transformer (Y/Y): Rated Voltage: 138/147 kV  
 Rated Power: 100 MVA  
 Leakage Resistance: 0.002 pu  
 Leakage Reactance: 0.05 pu

#### REFERENCES

- [1] E.Uzunovic (2001), *EMTP Transient Stability and Power Flow Models and Controls of VSC Based FACTS Controllers*, P.hd Thesis, University of Waterloo, Waterloo, Ontario, Canada.
- [2] J.Bian, D.G.Ramey, R.J.Nelson, and A.Edris (1997), "A Study of Equipment Sizes and Constraints for a Unified Power Flow Controller", *IEEE Trans. On Power Delivery*, Vol.12, No.3, pp. 1385-1391, July.
- [3] N.Li, Y.Xu, and H.Chen (2000), "FACTS Based Power Flow Control in Interconnected Power Systems", *IEEE Trans. On Power Systems*, Vol.15, No.1, pp. 257-262, Feb.
- [4] B.Fardanesh (2004), "Optimal Utilization, Sizing, and steady-State Performance Comparison of Multiconverter VSC-Based FACTS Controllers", *IEEE Trans. On Power Delivery*, Vol.19, No.3, pp. 1321-1327, July.
- [5] C.R.Fuerte-Esquivel, E.Acha, and A.Ambriz-Perez (2000), "A Comprehensive Newton-Raphson UPFC Model for the Quadratic Power Flow Solution of Practical Power Networks", *IEEE Trans. On Power Systems*, Vol.15, No.1, pp. 102-109, Feb.
- [6] K.K.Sen (1998), "SSSC-Static Synchronous Series Compensator: Theory, Modeling, and Applications", *IEEE Trans. On Power Delivery*, Vol.13, No.1, pp. 241-246, Jan.
- [7] A.H.Norouzi and A.M.Sharaf (2005), "Two Control Schemes to Enhance the Dynamic Performance of the STATCOM and SSSC", *IEEE Trans. On Power Delivery*, Vol.20, No.1, pp. 435-442, Jan.
- [8] A.C.Pradhan and P.W.Lehn (2006), "Frequency-Domain Analysis of the Static Synchronous Series Compensator", *IEEE Trans. On Power Delivery*, Vol.21, No.1, pp. 440-449, Jan.
- [9] C.A.Canizares (2000), "Power Flow and Transient Stability Models of FACTS Controllers for Voltage and Angle Stability Studies", *IEEE/PES WM Panel on Modeling, Simulation, and Applications of FACTS Controllers in Angle and Voltage Stability Studies*, Singapore, Jan.
- [10] C.J.Hatziadoniu and A.T.Funk (1996), "Development of a Control Scheme for a Series-Connected Solid-State Synchronous Voltage Source", *IEEE Trans. On Power Delivery*, Vol.11, No.2, pp. 1138-1144, April.
- [11] J.Kennedy and R.Eberhart (1995), "Particle Swarm Optimization", Proc. of IEEE Inter. Conf. on Neural Networks (ICNN), Vol.IV, pp. 1942-1948, Perth, Australia.
- [12] Y.Fukuyama and T.Yura (1999), "A Particle Swarm Optimization for Reactive Power and Voltage Control Considering Voltage Stability", Proc. of IEEE Inter. Conf. on Intelligent System Applications to Power Systems (ISAP), Rio de Janeiro, April.
- [13] S.Naka, T.Genji, T.Tura and Y.Fukuyama (2001), "Practical Distribution State Estimation Using Hybrid Particle swarm Optimization", Proc. of IEEE Power Eng. Society Winter Meeting, Ohio, USA, Jan.
- [14] A.Salem and V.K.Sood (2005), "Modeling of Series Voltage Source Converter Applications with EMTP-RV", Inter. Conf. on Power Systems Transients (IPST'05), paper no. IPST05-020, Montreal, Canada, June.