

Broadband PowerLine Communications: Performance Analysis

Justinian Anatory, Nelson Theethayi, M. M. Kissaka, and N. H. Mvungi

Abstract—Power line channel is proposed as an alternative for broadband data transmission especially in developing countries like Tanzania [1]. However the channel is affected by stochastic attenuation and deep notches which can lead to the limitation of channel capacity and achievable data rate. Various studies have characterized the channel without giving exactly the maximum performance and limitation in data transfer rate may be this is due to complexity of channel modeling being used. In this paper the channel performance of medium voltage, low voltage and indoor power line channel is presented. In the investigations orthogonal frequency division multiplexing (OFDM) with phase shift keying (PSK) as carrier modulation schemes is considered, for indoor, medium and low voltage channels with typical ten branches and also Golay coding is applied for medium voltage channel. From channels, frequency response deep notches are observed in various frequencies which can lead to reduce the achievable data rate. However, is observed that data rate up to 240Mbps is realized for a signal to noise ratio of about 50dB for indoor and low voltage channels, however for medium voltage a typical link with ten branches is affected by strong multipath and coding is required for feasible broadband data transfer.

Keywords—Powerline Communications, branched network, channel model, modulation, channel performance, OFDM.

I. INTRODUCTION

RECENTLY there has been interest in utilizing the power line network for broadband communication. The interest has risen because of the potential that power line network present to telecommunications users. It is envisaged that communication over power line can be used to bridge the digital rural-urban divide and provide alternative channel in urban areas. The potential to deliver broadband services over power line such as internet and home networking presents new opportunity in the telecommunication industries. The power lines connecting different points consist of cascaded cables of diverse line lengths with a number of branches of different line lengths and terminal loads. The terminal loads

Manuscript received September 30, 2006. This work was supported in part by the SIDA/SAREC through Faculty of Electrical and Computer Systems Engineering, University of Dar es Salaam, Tanzania.

J. Anatory, M. M. Kissaka and N. H. Mvungi are with the faculty of Electrical and Computer System, University of Dar es Salaam, P.O. Box 35131, Dar es Salaam, Tanzania (phone: +255-22-2410377; fax: +255-22-2410377; e-mail: anatory@engineer.com, mvungi@udsm.ac.tz, and kissaka@erb.go.tz).

Nelson Theethayi is with Division for Electricity and Lightning Research, Uppsala University, Sweden (e-mail: Nelson.Theethayi@angstrom.uu.se).

change with switching OFF/ON connected appliances/equipments hence changing frequency response of the network. Hence, utilizing of a power line network for communication has major challenges. The challenges include multipath, noise, stochastic attenuations etc. The noise in a power line network is said to consist of impulsive and background noise.

It has been reported that multi-carrier systems such as Orthogonal Frequency Division Multiplexing (OFDM) and Multi Carrier Code Division Multiplexing (MC-CDMA) can be suitable for such environments [1]. The Studies of utilizing OFDM technology are reported in [2] [3] and [4]. The studies in [2] show that multipath effects in power line network outweighs that of noise. The study on the effects of branches in power line networks was reported in [5] where quadrature amplitude modulation (QAM) was used. The results indicated possibility of degradation of channel performance with increase in number of branches. Therefore, the effects have to be investigated to enhance network stability and performance because in developing countries introducing extra branches in a network is common practice. In this study OFDM system is considered. In OFDM system the behavior of the entire system follows the general characteristics of a carrier modulation; we consider various carrier modulation schemes so as to get an insight of its behavior. The carrier modulations under consideration are BPSK, QPSK, 16PSK and 256PSK, in addition additive white Gaussian noise is used.

The paper is presented as follows; section two presents the power line channel model used in the investigation. Section three covers the OFDM performance issues; section four addresses performance analysis. Finally the conclusions are presented in section five.

II. POWER LINE CHANNEL MODEL

It has been said that to investigate power line network performance in detail so as to optimize its transmission system a reasonably accurate channel model must be available [6]. Hensen [7] proposed a simple power line model where attenuation was increasing with frequency that did not take into consideration the multipath phenomenon. The second model was proposed by Philipps *et al.* [8], whose transfer function is given by (1). In (1) out of N number of possible signal flow paths, each path delayed by time τ_i is multiplied by a complex factor ρ_i (product of transmission and reflection

factors).

$$H(f) = \sum_{i=1}^N \rho_i e^{-j2\pi f \tau_i} \quad (1)$$

The method in [8] was extended by Zimmermann *et al.* [9] to account for the attenuation of the signal flow and is given by (2). In (2) each path is characterized by weighting factor g_i (product of transmission and reflections factors) and path length d_i . The attenuation factor is modeled by the parameters a_0 , a_1 and k , which are obtained from measurements. Banwell *et al.* [10] proposed a model which accounts for a multi-conductor configuration. The model that power line researchers commonly use is that of Zimmermann *et al.* [9] since its modeling results conforms with that of measurements and is easy to apply. Although model is popular, it has some drawbacks, as highlighted in [10-12].

$$H(f) = \sum_{i=1}^N g_i e^{-(a_0 + a_1 f^k) \cdot d_i} e^{-j2\pi f \frac{d_i}{v_p}} \quad (2)$$

In our investigation the method proposed in [11 - 12] is used. To generalize the model used to suit any power line configuration, a power line network with distributed branches shown in fig. 1 was considered. The transfer function is given by (3a). In (3a), N_T is the total number of branches connected say at node '1' and terminated in any arbitrary load. Let $n, m, M, H_{mnd}(f)$ and T_{Lmd} , represent any branch number, any referenced (terminated) load, number of reflections (with total L number of reflections), transfer function between line n to a referenced load m at the referred node d , transmission factor at the referenced load m at referred node d respectively. With these the signal contribution factor α_{mnd} is given by (3b), where ρ_{nmd} is the reflection factor at node 'd' between line n to the referenced load m , γ_{nd} is the propagation constant of line n that has line length ℓ_n . All terminal reflection factors P_{Lnd} in general are given by (3c), except at source where $\rho_{L11} = \rho_s$ is the source reflection factor [12].

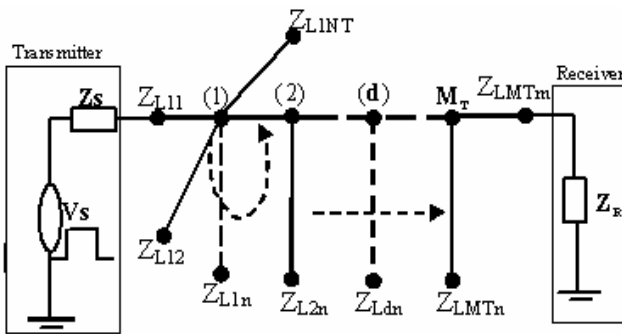

Fig. 1 Power line network with distributed

Also Z_s is the source impedance, Z_n is the characteristic impedance of any terminal with source while V_s and Z_{LdNT} are source voltage and load impedance respectively based on fig.1. The output referenced voltage $V_{mMT}(f)$ in frequency domain is given by (4). The time domain response is obtained by inverse Fourier transform of (4).

$$H_{mMT}(f) = \prod_{d=1}^{M_T} \sum_{L=1}^L \sum_{n=1}^{N_T} T_{Lmd} \alpha_{mnd} H_{mnd}(f) \quad n \neq m \quad (3a)$$

$$\alpha_{mnd} = P_{Lnd}^{M-1} \rho_{nmd}^{M-1} e^{-\gamma_{nd}(2(M-1)\ell_{nd})} \quad (3b)$$

$$P_{Lnd} = \begin{cases} \rho_s & d = n = 1(\text{source}) \\ \rho_{Lnd} & \text{otherwise} \end{cases} \quad (3c)$$

$$V_{mMT}(f) = H_{mMT}(f) * \left(\frac{Z_{Ldn}}{Z_{Ldn} + Z_s} \right) V_s \quad (4)$$

To demonstrate the validity of (3), consider the configuration shown in Fig. 2, the lengths $L_1, L_2, L_3, L_4, L_5, L_6, L_7$ and L_8 was assumed to be 60m, 200m, 100m, 200m, 200m, 100m, 200m and 200m respectively, with $Z_{L2} = \infty$, $Z_{L3} = Z_{L4} = Z_{L5} = Z_{L6} = Z_s = Z_1 = Z_2 = Z_3 = Z_4 = Z_5 = Z_6 = Z_7 = Z_8 = 496\Omega$. A 2V rectangular pulse with width of $0.5\mu s$, rise time $1ns$, and shifted by $0.5\mu s$ was applied as shown in Fig. 2. The voltage at the point G calculated using (4) and modeled with ATP-EMTP [13] and results shown in Fig. 3(a) and 3(b), respectively are in good agreement.

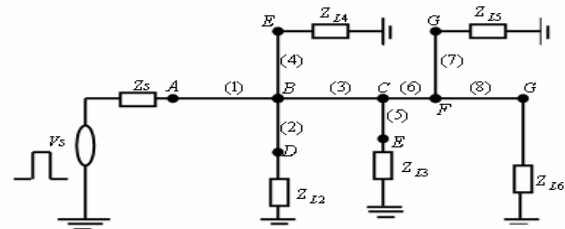

Fig. 2 Power line network with three distributed branches

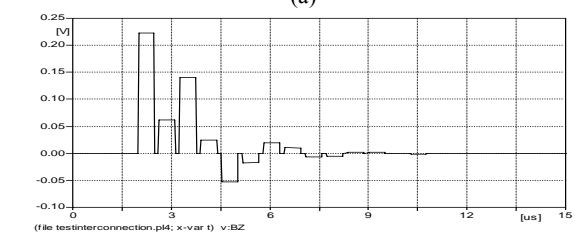
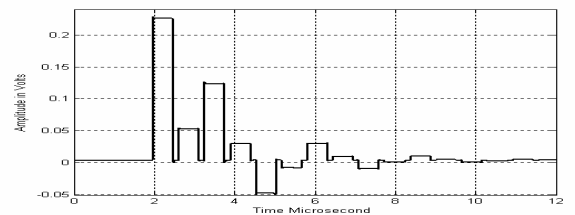

Fig. 3 Simulation Results (a) Model Result (b) ATP-EMTP Results

III. ORTHOGONAL FREQUENCY DIVISION MULTIPLEXING (OFDM) AND CHANNEL CODING

Power line channel is characterized by a multipath fading environment like wireless networks. This is due to number of concentrated but distributed branches of various lengths (both direct and branched lengths) and stochastically varying connected load impedances. The delayed waves due to loads and branches interfere with the direct waves and causes intersymbol interference (ISI), which degrades network performances. Because the delayed waves interfere with the direct waves, the delayed signals must be eliminated to improve the systems this can be realized using equalization techniques. However achieving equalization at megabits per second is cumbersome. OFDM is based on parallel broadband data transmission which reduces the effects of multipath and leads to unnecessary equalization techniques. The general configuration of OFDM transmission system is represented in Fig. 4[14].

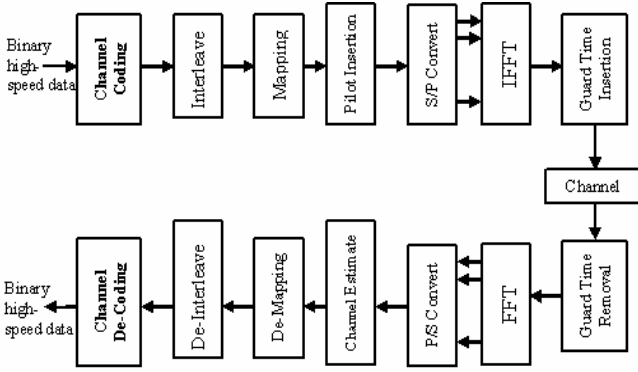

Fig. 4 Block diagram for multi-carrier transmission –OFDM

In the transmitter, the data being transmitted at high-speed is first coded, interleaved and then mapped. The high-speed data is converted into parallel data that is transmitted in several channels. Increasing the number of parallel transmission channels reduces the data rate that each individual sub-channel must convey. The transmitted data of each parallel sub-channel is modulated by either M-ary Phase shift keying (PSK) or M-ary Quadrature Amplitude Modulation (QAM). The data are fed into an Inverse Fast Fourier Transform (IFFT) circuit generating an OFDM signal. The signal is fed into a guard time insertion circuit to reduce ISI. At the receiver the guard time is removed, and the orthogonality of channels can be maintained by using FFT circuit at the receiver. Because the data in FFT circuit are parallel then the parallel to serial conversion is needed and since the power line uses coherent detection system, channel estimation is necessary. The estimates are important so that data can be demodulated correctly. Channel coding is also necessary to improve channel performance. The performance indication of modulation scheme in any communication channel is through bit error rate performance.

In this paper the M-PSK modulation scheme is considered. The formula of average Symbol Error Rate of M-PSK over

AWGN channels can be found is given as in (5), M is the modulation level, E_b is the energy and N_0 is the noise power. If the PSK modulation is used in each sub-carrier, the bit error rate of OFDM system is given as (6), the parameter N are the number of sub-channels [15] and H_k is sub-channel response.

For the case of coding, several high speed PLC systems are adopted the coded OFDM systems like block codes such as BCH, Hamming codes etc, convolutional codes, Reed-Solomon, concatenated codes, and turbo code. Current researches are proposing the use of Low-Density Parity-Check (LDPC) code. In this paper simple block code such as Golay coding is used. With this code the expression for a coded system is given by (7). The probability error for sub-channel can be obtained by (8) after averaging over all sub-channels. Next let us see how such analysis can be used to evaluate channel performance.

$$PM \approx 2Q \left(\sqrt{\frac{2(\log_2 M) H_k^2 E_b}{N_0} \sin \frac{\pi}{M}} \right) \quad (5)$$

$$BER_{OFDM_{avg}} \approx \frac{\sum_{k=1}^N \left(2Q \left(\sqrt{\frac{2(\log_2 M) H_k^2 E_b}{N_0} \frac{k}{n} \sin \frac{\pi}{M}} \right) \right)}{N} \quad (6)$$

$$Pb_k \approx \frac{q}{2(q-1)} (P_{w1k} + P_{w2k}) \quad (7a)$$

$$Pw1_k = \frac{d}{n} \sum_{i=t+1}^d \binom{n}{i} P_{sck}^i (1 - P_{sck})^{n-i} \quad (7b)$$

$$Pw1_k = \frac{1}{n} \sum_{i=d+i}^n \binom{n}{i} P_{sck}^i (1 - P_{sck})^{n-i} \quad (7c)$$

$$Psc_k \approx \frac{\sum_{k=1}^N \left(2Q \left(\sqrt{\frac{2(\log_2 M) H_k^2 E_b}{N_0} \frac{k}{n} \sin \frac{\pi}{M}} \right) \right)}{N} \quad (8)$$

IV. PERFORMANCES ANALYSIS

In the performance analysis medium channels, access channels and indoor channels (with 5 & 10 branches) for low voltage and medium voltage channel. For indoor channel the consideration was for 4 and 8 branches only. For medium and indoor channel the line termination was infinite to reflected the behavior of distribution transformers without protection and for indoor to reflect unplugged sockets. Low impedance termination was assumed for low voltage channel to reflect impedances of residential loads at higher frequencies. The frequency bands considered is from 0-30MHz for either channel. Fig. 5 and 6 shows the channel frequency used and impulse responses respectively for the assumed operating environment stated above. The impulse responses of the channel shows that the distributions of direct and delayed paths are $8\mu s$, $3\mu s$ and $1\mu s$ for medium channels, access channels and indoor channels respectively. Thus, the delay

spreads of the referenced channels are 8μs, 3μs and 1μs for medium, access and indoor channels respectively. The frequency responses show high attenuations experienced in various frequencies.

To avoid inter-symbol interference (ISI) and inter-channel interference (ICI), while losing less than 1dB due to guard interval insertion, the OFDM symbol interval was chosen to be 9 times the delay spread which is equal to 72μs, 27μs and 9μs for medium channels, access channels and indoor channel respectively. The sub-channels spacing are taken as inverse of 64μs, 24μs and 8μs, which are equivalent to coherence bandwidth of 16kHz, 42kHz and 125 kHz for medium, access and indoor channels respectively. Considering a maximum bandwidth of 30MHz, the maximum sub-carriers are calculated based on (9). The sub-channels are 1875, 714 and 240 for medium, access and indoor channels respectively. The maximum size of FFT in the OFDM system was considered to be greater than twice the number of sub-channels. This makes the FFT size selected in this case to be 4096, 2048 and 512 for medium channel, low voltage channel and indoor channel respectively. Their corresponding guard time should be ¼ of FFT size, making the selection to be 1024, 512 and 128 respectively.

$$\text{Subchannels} = \frac{\text{Bandwidth}}{\text{Coherence}} \quad (9)$$

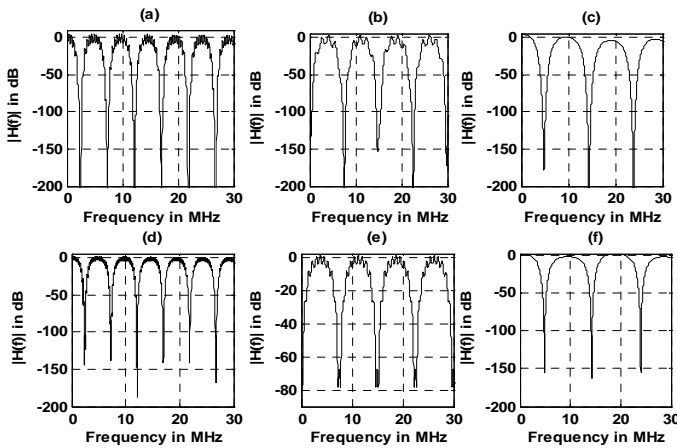

Fig. 5 Frequency Response of Power line network (a) Medium Channel, 10branches (b) Access Channel, 10branches (c) Indoor Channel, 8branches, (d) Medium Channel, 5branches (e) Access Channel, 5branches (f) Indoor Channel, 4branches

For comparison purposes the channel multipath from impulse responses were extracted and implemented in OFDM based system as shown in Fig. 4. The guard time and cyclic extended was considered as for a case of medium channels. Fig. 7 shows the performance for indoor channel with 8 branches, while Fig. 8 is the performance of low voltage channel. In all cases it can be observed that the data rate of 240Mbps is achieved. However, in some sub-carrier the channel can be degraded due to higher attenuations. Fig. 9 shows the performance of medium voltage with five branches and different data rate. It can be observed that as a signal to

noise ratio increase, the data rate is increased as expected. Higher data rate in OFDM is obtained by changing the modulation level. For example 30Mbps for BPSK and 240Mbps is for 256PSK.

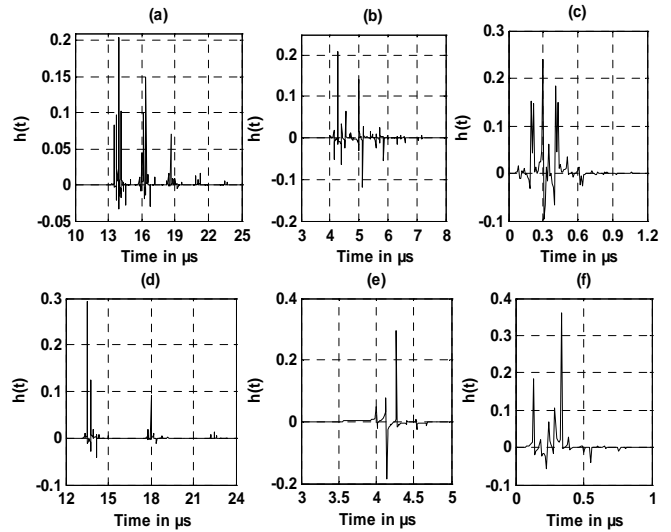

Fig. 6 Impulse Response of Power line network (a) Medium Channel, 10branches (b) Access Channel, 10branches (c) Indoor Channel, 8branches, (d) Medium Channel, 5branches (e) Access Channel, 5branches (f) Indoor Channel, 4branches

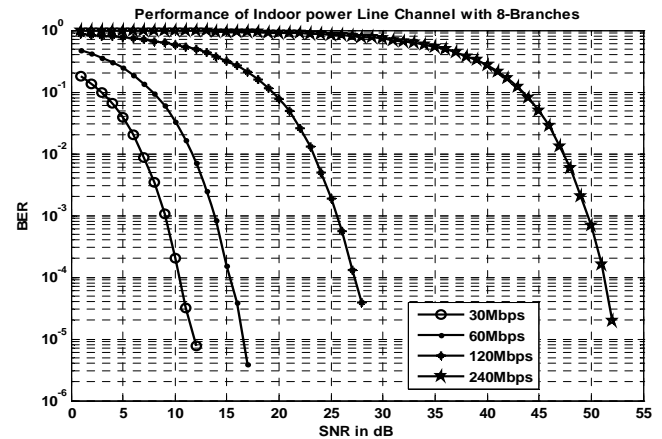

Fig. 7 Performance of Indoor channels based on OFDM system with M-PSK carrier modulation

The number of branches in the same system was increased to see weather the same performance can be obtained. The multipath for channel with ten branches as depicted in fig. 6a were considered and the sub-channel used is 1875 which gives us FFT size of 4096 and guard time with cyclic extension of 1024. The channel was simulated and Fig. 10 shows the performance of such system. It can be observed that the performance for uncoded system is very highly affected by multipaths. Golay code was applied for each sub-carrier and the equation depicted in (8) was used. From the results for a coded system with (23, 12) Golay code it can be observed that the performance is highly improved. In comparison with the medium channel with five branches it can be observed that, the performance of channel with five branches is the same as

coded system with ten branches.

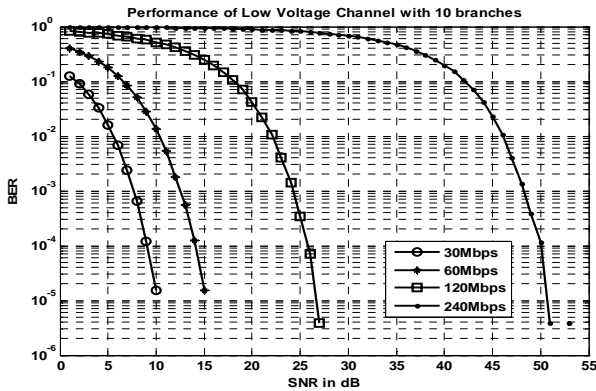

Fig. 8 Performance of Low voltage channels based on OFDM system with M-PSK carrier modulation

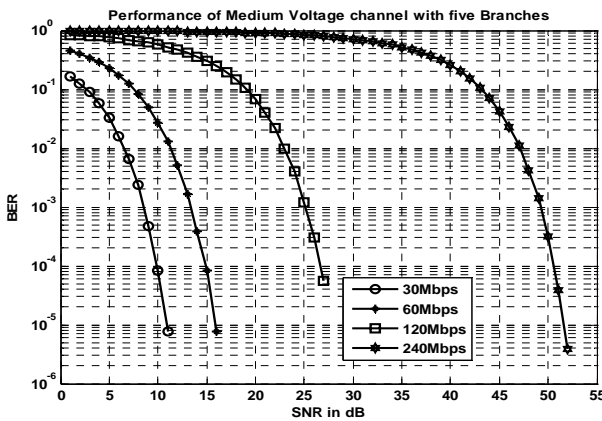

Fig. 9 Performance of Medium Voltage channels based on OFDM system with M-PSK carrier modulation

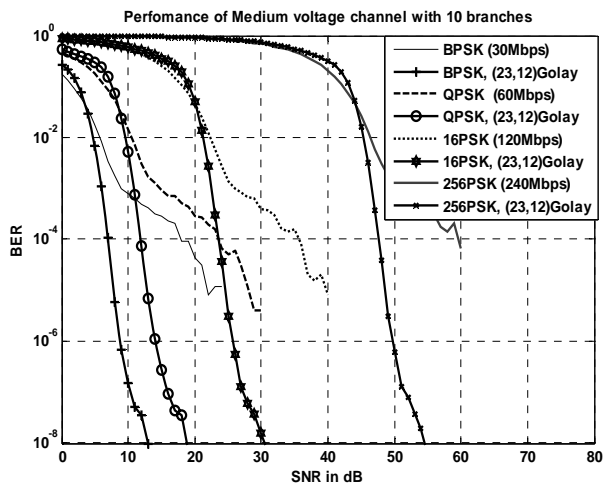

Fig. 10 Performance of Medium Voltage channels based on OFDM system with PSK carrier modulation

V. CONCLUSION

In this paper the performance of power line channel has been investigated under multipath conditions. It has been

observed that the data rate up to 240Mbps can be attained by increasing the modulation level. However in medium voltage channel, it can be observed that the performance for un-coded system is very highly affected. Golay code was applied for each sub-carrier and the equation depicted in (8) was used. It has been observed that the attainable data rate without coding in medium voltages is from 30Mbps-240Mbps depending on modulation level.

REFERENCES

- [1] J. Anatory, M.M. Kissaka and N.H. Mvungi, "Trends in Telecommunication Services Provision: Power line Network can provide alternative for Access in Developing countries", in the proc. of IEEE Africon, Gaborone, BOTSWANA, 2004, 601-606.
- [2] Y.H.Ma, P.L. So, E. Gunawan, "Performance Analysis of OFDM Systems for Broadband Powerline Communications under Impulsive Noise and Multipath Effects." IEEE Trans. On Power Delivery, Vol. 20, No. 2. April, 2004.
- [3] Kim, Y.-H., Kim, S.-C., OFDM Receiver Performance Analysis With Measured Power Line Channel Model For Coded OFDM System, Proceedings of the 9th IEEE International Symposium on Power-Line Communications, Vancouver, Canada, April 2005, pp. 201 - 205.
- [4] Ma, Y.H., So, P.L., Gunawan, E., Guan Y.L., Analysis of Impulsive Noise and Multipath Effects on Broadband Power Line Communications, Proceedings of the International Conference on Power System Technology, Singapore, November. 2004, pp. 1404 - 1409.
- [5] Justinian Anatory, M.M. Kissaka and N.H. Mvungi, "Powerline Communications: The effects of Branches in the network performance", to appear IEEE-ISPLC 2006, Florida, USA, March, 2006.
- [6] Ezio Biglieri and Politecnico di Torino, "Coding and Modulation for a Horrible Channel", IEEE Communications Magazine, May, 2003. pp. 92-98.
- [7] C. Hensen and W. Schulz, "Time Dependence of the Channel Characteristics of Low Voltage Power-Lines and its Effects on Hardware Implimentation," AEU Int'l. J. Electronics and Communication, vol. 54, no. 1, Feb. 2000, pp. 23-32.
- [8] H. Philipps, "Modelling of Powerline Communication Channels," Proc. 3rd Int'l. Symp. Power-Line Communications and its Applications, Lancaster, UK, 1999, pp. 14-21.
- [9] Zimmermann M. and Dostert K.; "A Multipath Model for the Powerline Channel", IEEE Trans. On Communications, vol. 50, No. 4, pp. 553-559, April 2002.
- [10] Stefano Gali and Thomas Banwell, "A Novel Approach to the Modeling of the Indoor Powerline Channel -Part II: Transfer Function and Its Properties", IEEE Trans. On Power Delivery, vol. 20, no.2, April 2005.
- [11] Justinian Anatory, N. Theethayi, R. Thottappillil, M.M. Kissaka, N.H. Mvungi, "The Effects of Interconnections and Branched Network In The Broadband Powerline Communications", Paper E06.2(01188), in Proc. of the XXVIIIth General Assembly of International Union of Radio Sciences, New Delhi, India, Oct. 23-29, 2005.
- [12] Justinian Anatory, M.M. Kissaka and N.H. Mvungi, "Channel Model for Broadband Powerline Communication, to appear IEEE Trans. On Power Delivery.
- [13] Dommel H. W., "Electromagnetic transients program (EMTP theory book)", Bonneville Power Administration, 1986.
- [14] Richard Van Nee, Ramjee Prasad, "OFDM for wireless multimedia communications," Boston, Artech House, 2000.
- [15] P. Amirshahi, S. M. Navidpour, M. Kavehrad, "Performance Analysis of Uncoded and Coded OFDM Broadband Transmission Over Low Voltage Powerline Channels with Impulsive Noise," to appear in IEEE Transactions on power delivery 2006
- [16] Despina Anastasiadou and Theodore Antonakopoulos, "Multipath Characterization of Indoor Powerline Networks", IEEE Trans. On Power Delivery, vol. 20, no.1, pp. 90-99, January, 2005.
- [17] Halid Hrasnica, Abdelfatteh Haidine and Ralf Lehnert, "Broadband Powerline Communications Networks-Network Design", John Wiley & Sons, Ltd, 2004.