

Application of Pattern Search Method to Power System Security Constrained Economic Dispatch

A. K. Al-Othman, and K. M. EL-Naggar

Abstract—Direct search methods are evolutionary algorithms used to solve optimization problems. (DS) methods do not require any information about the gradient of the objective function at hand while searching for an optimum solution. One of such methods is Pattern Search (PS) algorithm. This paper presents a new approach based on a constrained pattern search algorithm to solve a security constrained power system economic dispatch problem (SCED). Operation of power systems demands a high degree of security to keep the system satisfactorily operating when subjected to disturbances, while and at the same time it is required to pay attention to the economic aspects. Pattern recognition technique is used first to assess dynamic security. Linear classifiers that determine the stability of electric power system are presented and added to other system stability and operational constraints. The problem is formulated as a constrained optimization problem in a way that insures a secure-economic system operation. Pattern search method is then applied to solve the constrained optimization formulation. In particular, the method is tested using one system. Simulation results of the proposed approach are compared with those reported in literature. The outcome is very encouraging and proves that pattern search (PS) is very applicable for solving security constrained power system economic dispatch problem (SCED).

Keywords—Security Constrained Economic Dispatch, Direct Search method, optimization.

I. INTRODUCTION

POWER system security analysis is the process of detecting whether the power system is in a secure state or alert state. Secure state implies that the load is satisfied and no limit violations will occur under present operating conditions and in the presence of unforeseen contingencies. The alert state implies that either some limits are violated and/or the load demand cannot be met and corrective actions must be taken in order to bring the power system back to the secure state. The power system security problems are classified as static and dynamic. The static security problem implies evaluating the system steady state performance for all possible postulated contingencies. This means neglecting the transient behavior and any other time-dependent variations due to load-

generation conditions. The dynamic analysis evaluates the time-dependent transition from the pre-contingent state to the post-contingent state. Dynamic security has been analyzed either by deriving dynamic security functions only, or along with the development of some preventive action techniques [1-5].

Often, security analysis is introduced, to the economic study of an electric power system, in the form of security constraint had to be satisfied. A wide variety of optimization techniques have been applied in solving economic load dispatch problems (ELD). Some of these techniques are based on classical optimization methods while others are based on artificial intelligence methods or heuristic algorithms. Many references present the application of classical optimization methods, such as linear programming, quadratic programming, to solve the ELD problem [1, 2]. Classical optimization methods are highly sensitive to starting points and some times converge to local optimum solution or diverge altogether. Linear programming methods are fast and reliable but the main disadvantage associated with the piecewise linear cost approximation. Non-linear programming methods have a problem of convergence and algorithmic complexity. Newton based algorithms have a problem in handling a large number of inequality constraints [5]. Methods based on artificial intelligence techniques, such as artificial neural networks, were also presented in many references [3, 4]. Recently, many heuristic search techniques such as particle swarm optimization [5] and genetic algorithms [6] were applied successfully to the ELD problem. Hybrid methods were also presented in some references such as reference [7]. In this reference, the conventional Lagrangian relaxation approach, first order gradient method and multi-pass dynamic programming are combined together.

Recently, particular family of global optimization methods, introduced and developed by researchers in 1960 [8], has received a great attention. This family of methods called Direct Search methods. Direct Search methods are simply designed to search a set of point, around the current point, looking for a point that has less objective value than the current one has. This family includes *Pattern Search (PS)* algorithms, *Simplex Methods (SM)* (different from the simplex used in linear programming), *Powell Optimization (PO)* and others [9].

A. K. Al-Othman is with the Electrical Engineering Department, College of Technological Studies, Alrawda, 73452, P.O. Box 33198, Kuwait (e-mail: alothman@paaet.edu.kw).

K. M. EL-Naggar is with the Electrical Engineering Department, College of Technological Studies, Alrawda, 73452, P.O. Box 33198, Kuwait (e-mail: knaggar60@hotmail.com).

Direct Search methods, as apposed to more standard optimization methods, are often called derivative-free optimization methods, where they do not require any information about the gradient or even higher derivative of the objective function to search for an optimal solution. Therefore Direct Search methods may very well be used to solve non-continues, non-differentiable and multimodal, i.e. multiple local optima, optimization problem. Since the economic dispatch is one such problem, then the proposed method appears to be a good candidate to handle the economic dispatch problem.

The main objective of this study is to introduce the use of Pattern Search (PS) optimization technique to the subject of power system dynamic security with the most economical operating conditions. In this study Pattern Search (PS) method is employed to solve the security constrained economic dispatch problem (SCED). This new approach will be used to minimize the system objective cost function satisfying a set of dynamic security constraints. The pattern recognition technique, used in a previous work [10, 11], is utilized to introduce dynamic security constrained economic dispatch problem in a simple, powerful, and quick approaches. Such constraints have been employed in the development of the approach of preventive action under economic operation. In this approach, the goal is to shift the system state from an unstable area to stable area, if the system is in an alert condition, and at the same time, minimize the objective function.

II. SECURITY ASSESSMENT BY PATTERN RECOGNITION METHOD

As introduced, the dynamic security problem implies evaluating the system performance for all possible postulated contingencies. This means, for actual large systems, thousand of cases to be considered. The use of such approach in economic study of power system, as in our case, adds more computational difficulties which make it impossible to be practically applicable. Therefore, it is simpler and desirable to have an indicator for different modes of security. Such indicator may be presented in the form of simple mathematical function (classifier). The security assessment is then considered as a two class classification problem, namely secure or insecure. The classifier function is given as [12, 13].

$$\phi(x) = \omega^T x + \phi_o \quad (1)$$

where x is the vector of the system chosen features, ω is the coefficient vector, ϕ_o is an arbitrary constant.

Now, the system is considered secure if $\phi(x)$ greater or equal zero. On the other hand if the function value is negative, then the system is insecure.

Power generations, in the power system, can be considered as features in deriving the classifier due to the great effect of it

on the dynamic security [11]. In addition, this choice has the additional advantage of reducing the number of optimization variables, since the cost function is also formulated in terms of such powers.

III. PROBLEM FORMULATION

In this section the optimization problem is formulated as minimization of summation of the fuel costs of the individual generators, as in the economic dispatch. The objective function is then minimized subject to limits on generators outputs, as well as to the linear dynamic security constraints, set by pattern recognition technique [11]. A dynamic security constraint is derived for each contingency to be considered in the system. In mathematical form the problem can be stated as Minimization of:

$$F = \sum_{i=1}^N F_i = \sum_{i=1}^N (d_i + b_i P_{gi} + c P_{gi}^2) \quad (2)$$

Subject to

$$\sum_{i=1}^N P_{gi} = P_D + P_L \quad (3)$$

$$P_{gi(\min)} < P_{gi} < P_{gi(\max)}, i \in N_s \quad (4)$$

$$\phi_j(P_g) > 0, j = 1, 2, \dots, N_f \quad (5)$$

where:

F	System overall cost function
N	Number of generators in the system
d_i, b_i, c_i	Constants of fuel function of generator # i
ϕ_j	Classifier function related to contingency j
P_{gi}	Active power generation of generator number i
P_D	Total power system demand
P_L	Total system transmission losses
$P_{gi(\min)}$	Minimum limit on active power gen. of gen. i
$P_{gi(\max)}$	Maximum limit on active power gen. of gen. i
N_s	Set of generators in the system
N_f	Total number of contingencies considered
P_g	Array of active power generation in the system

It is important to mention here that the system losses will be ignored for simplification. The inclusion of such losses is easily possible, but it requires some modifications to take care of changes that will be introduced in equation (3). Furthermore, studying all possible contingencies would enlarge the problem size, thus a limited number of contingencies is only considered. Adding a high efficient contingency ranking routine to the developed program, would be appreciable and useful.

IV. PATTERN SEARCH METHOD

The Pattern Search (PS) optimization routine is an evolutionary technique that is suitable to solve a variety of optimization problems that lie outside the scope of the standard optimization methods. Generally, PS has the advantage of being very simple in concept, and easy to implement and computationally efficient algorithm. Unlike other heuristic algorithms, such as GA, PS possesses a flexible and well-balanced operator to enhance and adapt the global and fine tune local search. A historic discussion of direct search methods for unconstrained optimization is presented in reference [9]. The authors gave a modern prospective on the classical family of derivative-free algorithms, focusing on the development of direct search methods.

The Pattern Search (PS), algorithm proceeds by computing a sequence of points that may or may not approaches to the optimal point. The algorithm starts by establishing a set of points called *mesh*, around the given point. This current point could be the initial starting point supplied by the user or it could be computed from the previous step of the algorithm. The mesh is formed by adding the current point to a scalar multiple of a set of vectors called a *pattern*. If a point in the mesh is found to improve the objective function at the current point, the new point becomes the current point at the next iteration.

This maybe better explained by the following:

First: The Pattern search begins at the initial point X_0 that is given as a starting point by the user. At the first iteration, with a scalar =1 called *mesh size*, the pattern vectors are constructed as $[0 \ 1]$, $[1 \ 0]$, $[-1 \ 0]$ and $[0 \ -1]$, they may be called direction vectors. Then the Pattern search algorithm adds the direction vectors to the initial point X_0 to compute the following mesh points:

$$\begin{aligned} X_0 + [1 \ 0] \\ X_0 + [0 \ 1] \\ X_0 + [-1 \ 0] \\ X_0 + [0 \ -1] \end{aligned}$$

Figure1 illustrates the formation of the mesh and pattern vectors. The algorithm computes the objective function at the mesh points in the order shown.

The algorithm polls the mesh points by computing their objective function values until it finds one whose value is smaller than the objective function value of X_0 . If there is such point, then the poll is successful and the algorithm sets this point equal to X_1 .

After a successful poll, the algorithm steps to iteration 2 and multiplies the current mesh size by 2, (this is called the *expansion factor* and has a default value of 2). The mesh at iteration 2 contains the following points: $2*[1 \ 0] + X_1$, $2*[0 \ 1]$

$+ X_1$, $2*[-1 \ 0] + X_1$ and $2*[0 \ -1] + X_1$. The algorithm polls the mesh points until it finds one whose value is smaller the objective function value of X_1 . The first such point it finds is called X_2 , and the poll is successful. Because the poll is successful, the algorithm multiplies the current mesh size by 2 to get a mesh size of 4 at the third iteration because the expansion factor =2.

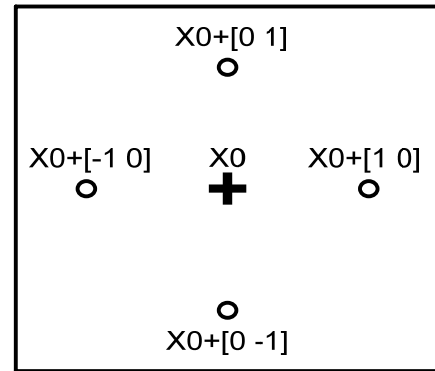

Fig. 1 PS Mesh points and the Pattern

Second: Now if iteration 3, (mesh size= 4), ends up being unsuccessful poll, i.e. none of the mesh points has a smaller objective function value than the value at X_2 , so the poll is called an unsuccessful poll. In this case, the algorithm does not change the current point at the next iteration. That is, $X_3 = X_2$. At the next iteration, the algorithm multiplies the current mesh size by 0.5, a contraction factor, so that the mesh size at the next iteration is smaller. The algorithm then polls with a smaller mesh size.

The Pattern search optimization algorithm will repeat the illustrated steps until it finds the optimal solution for the minimization of the objective function. The algorithm stops when any of the following conditions occurs:

- The mesh size is less than mesh tolerance.
- The number of iterations performed by the algorithm reaches the value of max iteration.
- The total number of objective function evaluations performed by the algorithm reaches the value of Max function evaluations.
- The distance between the point found at one successful poll and the point found at the next successful poll is less than X tolerance.
- The change in the objective function from one successful poll to the next successful poll is less than function tolerance.

All the parameters involved in the Pattern search optimization algorithm can be pre-defined subject to the nature of the problem being solved.

Constraint Handling

Many ideas were suggested to insure that the solution will satisfy the constraint [12]. The constraint can be augmented with the objective function using Lagrange multipliers. In this way the size of the problem will increase by introducing new parameters. In this study, the Pattern Search (PS) method handles constraints by using augmented Lagrangian to solve the nonlinear constrained economic dispatch problem [14-17]. The variables bounds and linear constraints are handled separately from nonlinear constraints. In which a sub-problem is formulated and solved, (having the objective function and nonlinear constraint function), using the Lagrangian and the penalty factors. Such sub-problem is minimized using a pattern search method, where that the linear constraints and bounds are satisfied. For more explanation on how PS handles constraints refer to [16, 18, 19].

V. NUMERICAL RESULTS

The main objective of the proposed approach is to have a secure, reliable and optimal economic power generation. To test the accuracy of the proposed formulation, two standard test systems are used [6, 12, 13]. The security functions used with the two systems for different three phase faults at different locations were derived before in reference [12]. For simplicity, transmission losses are ignored in the test.

A. Test System 1 [6, 12, 13]

Fig. 2 shows the 2-machine, 5-bus, 6- line test-system considered to test the proposed method. The system data is given in references [12, 13]. The system dynamic security has been studied under six different three-phase faults listed in Table I. The system classifiers which are given and driven in reference [12] are also shown in this table.

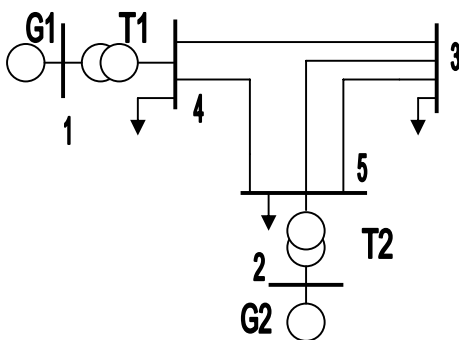

Fig. 2 Single line diagram of system 1

TABLE I
DYNAMIC SECURITY CLASSIFIERS FOR DIFFERENT CONTINGENCIES (SYSTEM 1)*

Classifier#	Fault line	Near Bus	Classifier parameters		
			ϕ_0	ω_1	ω_2
1	3-5	3	-1.0	4.0000	-1.90000
2	4-5	5	2.0	9.6250	-3.81250
3	4-5	4	-2.09	6.9875	-1.11875
4	3-5	5	-1.0	4.0000	-1.90000
5	3-4	3	-3.25	8.7812	-1.15371
6	3-4	4	-3.20	11.2687	-1.41125

* THREE PHASE FAULTS CONSIDERED IN CLASSIFYING THE INITIAL SAMPLING POINT SYSTEM 1

* THE SYSTEM CLASSIFIERS ARE TAKEN AS IN REFERENCE 10 AND THE TOTAL DEMAND = 7 P.U.

The problem formulated above is solved using PS optimization technique. The function *patternsearch()* was employed to solve the above minimization process. This function implements PS algorithm and is included in the GA & DS toolbox of Matlab [21]. An initial guess for the two unknowns (for P_{g1} & P_{g2}) has been set = 10. Extensive runs show that the best generation states are:

$$P_{g1} = 4.6760 \text{ p.u.} \quad P_{g2} = 2.3230 \text{ p.u.}$$

This state of generation is the absolute secure operating point for this system under any of the considered faults. The most economic generation cost for this situation is

$$F_{min} = 1868.18 \text{ \$/hr}$$

This solution is obtained after 62 iterations. The convergence in the minimization process is illustrated in Fig. 3.

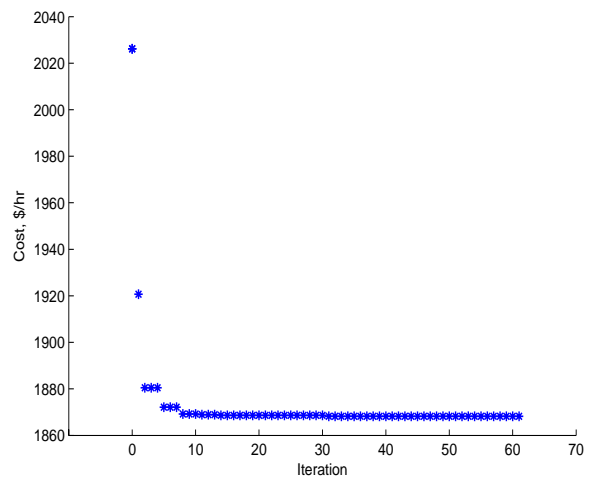

Fig. 3 Reduction cost function F

Table II shows a comparison of the optimal generators output obtained by PS and those obtained earlier, [6, 13], by genetic algorithms and quadratic programming for test-system 1. Note that the cost obtained by PS is almost the same as that obtained by QP (higher by less than 0.01 %). On the other hand, optimal result obtained by GA is about 3% higher.

Fig. 4 depicts the mesh size through out the convergence process. It is apparent from the figure that the mesh size decreases until the algorithm terminates in this case at mesh size: 1.9073e-006 which is less than the giving as stopping criteria. The sign \square in Fig. 4 at iteration # 0 indicates the initial value of the mesh size used. At iteration # 0, the poll was unsuccessful since the mesh size increased in iteration #1, (o sign indicates unsuccessful polls in the previous iteration), and therefore the algorithm has to expand the scope of the search by enlarging the mesh size. This is accomplished by multiplying the current mesh size by the expansion factor. In this study the expansion factor used is 2. As a result the mesh size has increase at iteration # 1. The same scenario happened in iteration # 2, since the mesh size increased to 4. At iteration #3 the mesh size has decreased, by multiplying the current mesh size by the extracting factor, indicating a successful poll in the previous iteration. The extracting factor used in this study is 0.5. The sign * indicated successful polls in the previous iteration.

TABLE II
GENERATORS OUTPUT AND COST FOR TEST-SYSTEM 1

Method	P _{g1} , (p.u.)	P _{g2} , (p.u.)	Cost, (\$/hr)
PS	4 6760	2 3230	1868.18
GA [6]	4 7214	2 4144	1925.88
QP [13]	4 6700	2 3300	1868.00

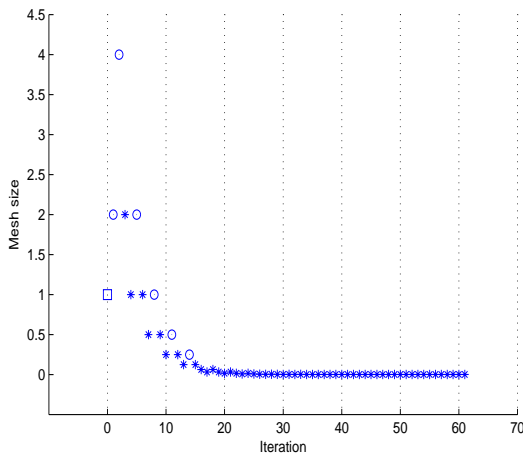

Fig. 4 Mesh size

PS has a very attractive feature while polling a set of point in a mesh. When the algorithm polls a mesh, as soon as it finds a point, a potential solution, whose objective value is less than the one of the current point, it would stop polling process and this potential solution would be taken as current point for the next iteration. This feature is called *incomplete poll*. Incomplete poll would eventually save on computation time. On the other hand, if it is also possible to perform a complete assessment of all penitential solutions if it is desired. This feature is called *complete poll*. Figure 5 shows the number of function counts that the PS algorithm had made, at all iteration, in order to evaluate the potential solution. When

the incomplete polling option was chosen, in iteration # 0, for example, only the first potential solution had been polled and found to have better objective value than the current point. Therefore, the poll has been set to be successful and the point had been taken as the current point for the next iteration (since it is better solution). While at other iterations, such as iterations # 9 and # 30, the PS algorithm had to poll 4 and 6 possible solutions, respectively, up until it found a better solution point than the current one.

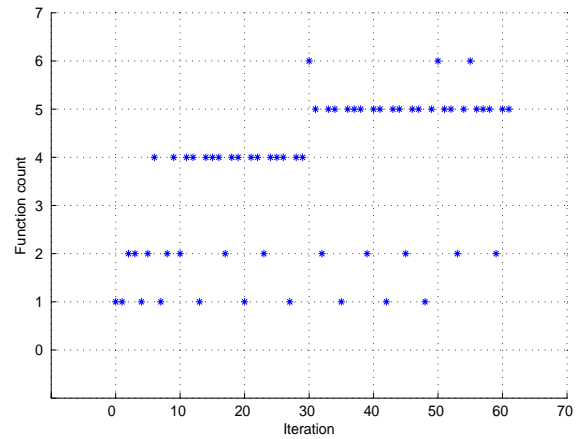

Fig. 5 Function count

VI. CONCLUSION

This paper introduces a new solution approach based on pattern search optimization to solve the problem of power system economic dispatch with. The problem is formulated as a constrained optimization problem. The proposed method has been tested on a five bus system. When compared with GA and EP, the analysis results have demonstrated that PS outperforms GA and EP in terms of reaching a better optimal solution and speed. On the other hand, PS, unlike GA and EP, is very sensitive to the initial guess and therefore, it appears to rely heavily on how close the given initial point to the global solution. This in turn makes the PS method quite susceptible to getting trapped in local minima.

Based on the analysis and the outcome of this study the, it is worth mentioning that PS can be applied to a wide range of optimization problem in the area of power system.

ACKNOWLEDGMENT

This work has been supported by the Public Authority of Applied Science & Training, Kuwait. Project # TS-06-02.

REFERENCES

- [1] R. B. Alder, "Security consideration economic dispatch with participation factors," IEEE Transactions on Power Apparatus and Systems, vol. PAS-96, 1977.
- [2] R. T. Bui and S. Ghaderpanah, "Real power rescheduling and security assessment," IEEE Transactions on Power Apparatus and Systems, vol. PAS-101, pp. 2906-15, 1982.

- [3] M. EL-Sharkawy and D.Nieebur, "Artificial Neural Networks with application to power systems," IEEE Power Engineering Society, A Tutorial course, 1996.
- [4] T. Yalcinoz and M. J. Short, "Neural networks approach for solving economic dispatch problem with transmission capacity constraints," IEEE Transactions on Power Systems, vol. 13, pp. 307-13, 1998.
- [5] R. K. Pancholi and K. S. Swarup, "Particle swarm optimization for security constrained economic dispatch," presented at International Conference on Intelligent Sensing and Information Processing. (IEEE Cat. No.04EX783), Chennai, India, pp. 7-12, 2004.
- [6] H. K. Youssef and K. M. El-Naggar, "Genetic based algorithm for security constrained power system economic dispatch," Electric Power Systems Research, vol. 53, pp. 47-51, 2000.
- [7] C. L. Chen and N. Chen, "Direct search method for solving economic dispatch problem considering transmission capacity constraints," IEEE Transactions on Power Systems, vol. 16, pp. 764-769, 2001.
- [8] R. Hooke and T. A. Jeeves, "Direct search solution of numerical and statistical problems," Journal of the Association of Computing Machinery, vol. 8, pp. 212-229, 1961.
- [9] R. M. Lewis, V. Torczon, and M. W. Trosset, "Direct search methods: then and now," Journal of Computational and Applied Mathematics, vol. 124, pp. 191-207, 2000.
- [10] C. K. Pang, F. S. Prabhakara, A.H.Abid, and A. J. Koivo, "Security evaluation in power systems using pattern recognition," IEEE Trans. on Power Apparatus and Systems, pp. 969-976, 1974.
- [11] H. mashhadi, "Pattern recognition technique for fast on-line security assessment of large interconnected power systems," IEEE Trans. on Power System, pp. 3816-3824, 1983.
- [12] H. K. Youssef, M.El-Shibini, and G.A.Hazaa, "Some new aspects in power system dynamic security using pattern recognition," presented at Second Middle East Power Conference. MEPCON-92, pp. 308-313, 1992.
- [13] H. K. Youssef, M. El-Shibini, and G. A. W. Hazza, "Power system security with the consideration of economic dispatch," presented at the Mediterranean Electrotechnical Conference - MELECON, Antalya, Turkey, pp. 889-892, 1994.
- [14] R. M. Lewis and V. Torczon, "Pattern search algorithms for linearly constrained minimization," SIAM Journal on Optimization, vol. 10, pp. 917-941, 1999.
- [15] R. M. Lewis and V. Torczon, "Pattern search algorithms for bound constrained minimization," SIAM Journal on Optimization, vol. 9, pp. 1082-99, 1999.
- [16] R. M. Lewis and V. Torczon, "A globally convergent augmented Lagrangian pattern search algorithm for optimization with general constraints and simple bounds," SIAM Journal on Optimization, vol. 12, pp. 1075-89, 2001.
- [17] V. Torczon, "On the convergence of pattern search algorithms," SIAM Journal on Optimization, vol. 7, pp. 1-25, 1997.
- [18] A. R. Conn, N. I. M. Gould, and P. L. Toint., "A globally convergent augmented Lagrangian algorithm for optimization with general constraints and simple bounds," SIAM Journal on Numerical Analysis, vol. 28, pp. 545--572, 1991.
- [19] E. Abu-Al-Feilat, M. Bettayeb, H. Al-Duwaish, M. Abido, and A. Mantawy, "A neural network-based approach for on-line dynamic stability assessment using synchronizing and damping torque coefficients," Electric Power Systems Research, vol. 39, pp. 103-110, 1996.
- [20] D. C. Walters and G. B. Sheble, "Genetic algorithm solution of economic dispatch with valve point loading," Power Systems, IEEE Transactions on, vol. 8, pp. 1325-1332, 1993.
- [21] N. Sinha, R. Chakrabarti, and P. K. Chattopadhyay, "Evolutionary programming techniques for economic load dispatch," Evolutionary Computation, IEEE Transactions on, vol. 7, pp. 83-94, 2003.
- [22] K. P. Wong and Y. W. Wong, "Thermal generator scheduling using hybrid genetic simulated-annealing," Generation, Transmission and Distribution, IEE Proceedings-, vol. 142, pp. 372-380, 1995.