

The CEO Mission II, Rescue Robot with Multi-Joint Mechanical Arm

Amon Tunwannarux, and Supanunt Tunwannarux

Abstract—This paper presents design features of a rescue robot, named CEO Mission II. Its body is designed to be the track wheel type with double front flippers for climbing over the collapse and the rough terrain. With 125 cm. long, 5-joint mechanical arm installed on the robot body, it is deployed not only for surveillance from the top view but also easier and faster access to the victims to get their vital signs. Two cameras and sensors for searching vital signs are set up at the tip of the multi-joint mechanical arm. The third camera is at the back of the robot for driving control. Hardware and software of the system, which controls and monitors the rescue robot, are explained. The control system is used for controlling the robot locomotion, the 5-joint mechanical arm, and for turning on/off devices. The monitoring system gathers all information from 7 distance sensors, IR temperature sensors, 3 CCD cameras, voice sensor, robot wheels encoders, yaw/pitch/roll angle sensors, laser range finder and 8 spare A/D inputs. All sensors and controlling data are communicated with a remote control station via IEEE 802.11b Wi-Fi. The audio and video data are compressed and sent via another IEEE 802.11g Wi-Fi transmitter for getting real-time response. At remote control station site, the robot locomotion and the mechanical arm are controlled by joystick. Moreover, the user-friendly GUI control program is developed based on the clicking and dragging method to easily control the movement of the arm. Robot traveling map is plotted from computing the information of wheel encoders and the yaw/pitch data. 2D Obstacle map is plotted from data of the laser range finder. The concept and design of this robot can be adapted to suit many other applications. As the Best Technique awardee from Thailand Rescue Robot Championship 2006, all testing results are satisfied.

Keywords—Controlling, monitoring, rescue robot, mechanical arm.

I. INTRODUCTION

RESCUE robot design and implementation is an interesting combination of allowing basic research while being application oriented [1]. The focus for the rescue robot application is on difficult terrain and simple platforms that mainly act as mobile explorer by cameras [2]. Rescue Robots

Manuscript received February 27, 2007. This work was supported by the CEO Mission II Rescue Robot project under Grant from University of the Thai Chamber of Commerce.

Asst. Prof. Amon Tunwannarux is with the Electronics and Telecommunications Engineering Department, School of Engineering, University of the Thai Chamber of Commerce, Bangkok 10400, Thailand (e-mail: amon_tun@utcc.ac.th).

Asst. Prof. Supanunt Tunwannarux is with the Electronics and Telecommunications Engineering Department, School of Engineering, University of the Thai Chamber of Commerce, Bangkok 10400, Thailand (e-mail: supanunt_hir@utcc.ac.th).

are designed in many ways. Their most functions usually are for exploration and collecting information of victims in the hazardous situation which is too risky to send human inside. Some rescue robots use their small size features for going deep into area. The robot from Tiny Seekers team (Japan) [3] is the good example of small size and walking robot which has the good point of going into narrow place and overcoming rugged terrain. However the small size robots will have a problem if they want to climb over the step that's higher than their height and want to move fast. There are some jumping rescue robots which try to move over the high obstacles by using a pneumatic cylinder [4]. Many times the explorers need to look from top view or look over partition for making decision of journey. Such as the rescue robot from CEO Mission I Team (Thailand) [5], the camera on the top of 125-cm. high mast is used for looking over the 80-cm. high partitions and accurately marks the locations of victims in the competition arena. In whatever way, the high mast equipment is only having two degree of freedoms. It can not stretch to any desire directions for sensing victim's vital sign. So we solve this problem with the design and implementation of a rescue robot with five degree of freedoms mechanical arm which can stretch to 125 cm. long. Many sensors can be installed at tip of arm, for situation surveillance from high level as well as getting vital sign of victims easier and faster.



Fig. 1 The CEO Mission II, rescue robot with multi-joint mechanical arm in the Thailand Rescue Robot Championship 2006

This paper focuses on the systems of hardware and software which control robot locomotion and mechanical arm movement. It gives the details to the hardware and software of monitoring system as well. The rest of this paper is structured as follows. Section two gives an overview of the hardware of the robot. In section three, the robot mechanical parts are explained. Section four illustrates the sensors equipped on the robot. Section five gives the detail of the basic software aspects and the higher level software onboard the robot. The software on the operator station is also presented in this section. Section six is the testing results and discussions. Section seven is the conclusion and the future work.

II. THE RESCUE ROBOT HARDWARE CONCEPT

As mentioned in the introduction, this robot is developed to solve the problem of the previous version CEO Mission I robot to have the better victim access ability. In Fig. 1, the CEO Mission II is showing how to use the multi-joint mechanical arm to explore the vital signs of a victim in the box which locate in the upstairs. It is faster and easier to sense the vital signs.

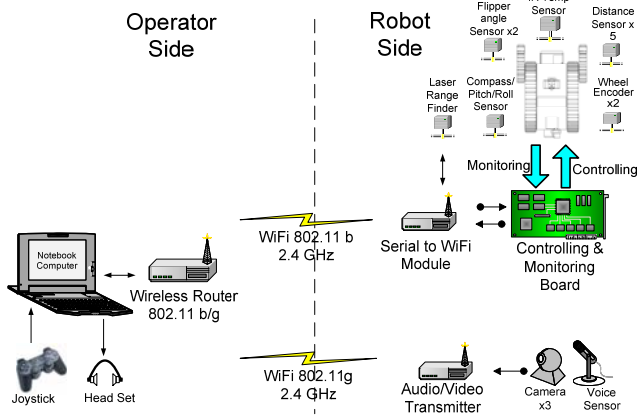

Fig. 2 Block diagram of the rescue robot system

Our main design concept is using the simple method but highly effective and reliable. The block diagram of the rescue robot system is shown in Fig. 2. The robotic system design is separated to two parts of functions; those are the controlling and monitoring. All of controlling commands are sent from operator’s computer to robot via Wi-Fi 802.11b. The controlling commands compose of the locomotion control, robot’s device on-off and multi-joint mechanical arm control. While all signals from robot sensors are monitored and sent via Wi-Fi 802.11b. In order to monitor audio and video in real time, another transmitter is required via Wi-Fi 802.11g. So we can get the 30 frames/sec. video rate for 324x248 resolution size. A wireless router 802.11 b/g is used at operator side for communication between operator and robot.

Because controlling function and monitoring function are divided as shown, the hardware on robot is quite simple as shown in Fig. 3. Three CPUs are used separately for each

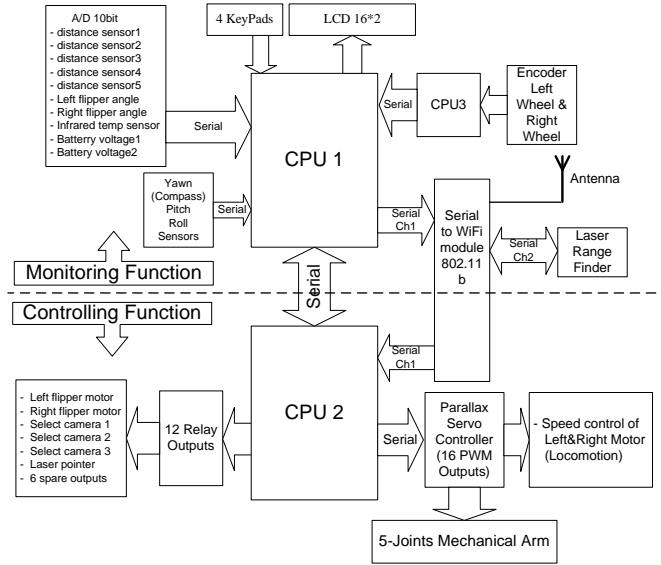

Fig. 3 Block diagram of hardware on robot

function. They communicate with each other via serial port pin. The CPU1, 40pins, MCS51, is assigned for all data sensing collection such as, 5 distance sensors, left/Right flipper angles, infrared temperature sensor, 2 voltages of batteries, and compass/pitch/roll angle of robot body. The CPU3, 20 pins, MCS51, is used only for counting encoder pulse of left/right robot wheel. All of collecting data is wirelessly sent to the operator side via serial to Wi-Fi module 802.11b. In addition, the CPU1 also handle 4 key pads and 16 x 2 characters LCD display. The display is very useful for robot sensors testing without wireless communication. The CPU2, 40 pins, MCS51, is set up for all equipment control, left/right flipper control and multi-joint mechanical arm control. Because of having 5 PWM signals of servos in mechanical arm and 2 PWM signals of speed control modules in locomotion, a special servo controller CPU is required.



Fig. 4 The CEO Mission II robot is exploring a victim in car

III. ROBOT MECHANICAL PART

The rescue robot is tracked wheel vehicle. They are relatively lightweight (about 30 kg.) and have a small footprint (approximately 50cm. x 60cm.) They are quite active and fast in unstructured environments and they also perform well on uneven terrain. This hold for tracked vehicles in general [6][7], which can also be seen by their popularity in the RoboCup rescue league, for example in the robots of Team Freiburg, Robhaz, Casualty, IRL and IUB [8][9][10][11][12]. The track wheel robots which mentioned above are variety designs. Each design has different good points. In this robot, the tracks which use for the locomotion are double tracks (wheel track and flipper track) as shown in Fig 4. They are very useful for climbing over the pile of collapse.

A. Body and Locomotion Driving System

The 3.5 mm. thick aluminum sheet is folded to be the base frame. The locomotion driving system (all motors and gear sets) and the batteries are placed in this frame in order to have the low level center of gravity (Fig. 5). Two 24V DC motors are used for driving two front wheels separately. The track driving system with two shafts in same rotating center is designed in order to drive wheel track and flipper track together.

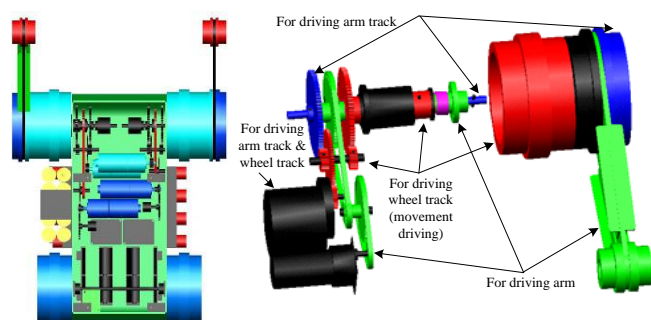

Fig. 5 The driving system of tracks and flippers

B. Flipper Driving System

These flippers are created in order to raise robot body up for better climbing. All driving mechanic are designed to locate at the shaft of front wheel so most of robot weight tends to be at the front. This is very important for climbing up the stairs. Another two 24V DC motors and transmission chains are required for flippers driving as shown in Fig 5.

TABLE I
DETAILS OF MULTI-JOINT MECHANICAL ARM

Joint No.	Name of Joint	RC Servo Part No.	Torque@ Servo (kg.cm)	Gear Reduction Ratio
1	Base	HS-815BB	24.7	22.75
2	Four bar link	HS-815BB	24.7	22.75
3	Elbow	HS-815BB	24.7	9.0
4	Tilt	HS-945MG	11.0	5.0
5	Pan	HS-945MG	11.0	1.0

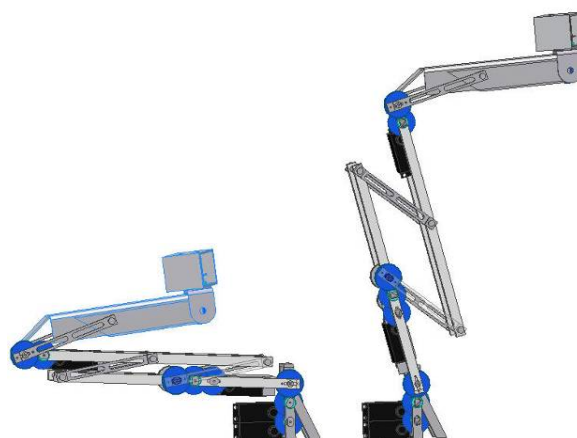

Fig. 6 Multi-joint mechanical arm

C. Multi-Joint Mechanical Arm

The mechanical arm does credit to the rescue robot. It helps the robot to explore in many ways such as, from high level, going to narrow space and able to get vital signs of victims easier and faster. In Fig. 6 shows the drawing of mechanical arm which has 5 degrees of freedom. Because the pay load at the tip of arm is small and the arm structure weight is not much, servo motor with gear set still can regulate the joint angle quite well. Resistor potentiometer is installed for each joint angle feedback. Size, part number of servo motors and gear ratios of each joint are shown in Table I.

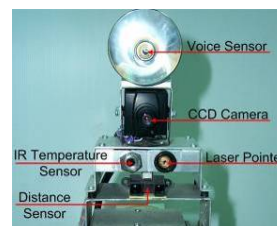

Fig. 7 Tip of the mechanical arm and joystick for the operator to control the robot

D. Tip of the Mechanical Arm

This part is the place to install many sensors which are used for searching vital sign of the victims such as an IR temperature sensor, a voice sensor, a distance sensor, and two CCD cameras as shown in Fig. 7. It also handles a laser pointer for pointing the measuring location.

IV. SENSORS

The infrared distance sensor, Sharp GP2Y0A02YK, with the detection range 20-150 cm. is used to measure the distance from the tip of mechanical arm to the pointed object (see Fig. 7). It has less influence on the colors of reflected objects and their reflectivity, due to optical triangle measuring method [13]. Moreover, we also installed 6 infrared distance sensors, Sharp GP2D120, with the detection range 4 – 30 cm, around robot body for obstacle detecting.

The infrared (IR) temperature sensor is chosen to use for measuring the victim temperatures remotely and contactlessly. We use the Raytek MID Module [14], which has the important specifications to be concerned as

- Optical Resolution = 10:1 provides the ability to measure temperature of the pointed area
- The miniature sensing head can be separated from main unit and has small size and light weight (see Fig. 7)

The voice sensor, a small conventional wide range condenser microphone is equipped at the center of parabolic cone for voice focusing as in Fig. 7.

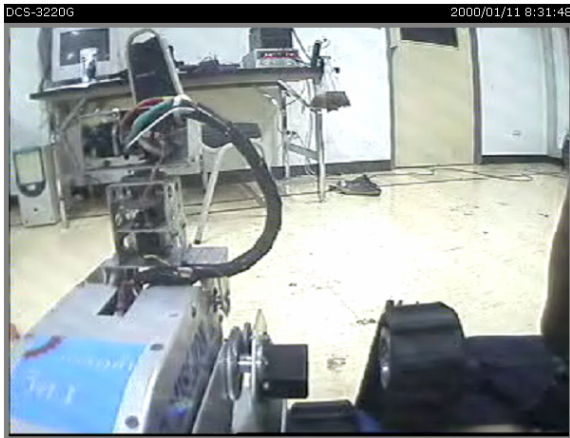

Fig. 8 A clear view from a driving camera

For visual system, two color CCD cameras are installed on the tip of mechanical arm. The 1st one is for the front view and the 2nd one is for the rear view. Another color CCD camera (the 3rd one) with wide angle lens (equipped at the back of robot) is used as robot driving. A clear view from the 3rd camera is shown in Fig.8.

Two encoders are attached to the left front wheel shaft and the right front wheel shaft for acting as odometer sensor. The data of each wheel sensor can be used to plot the victim access route.

Flipper angle sensors are necessary for remote controlling. The angle data of each flipper is used for robot graphic creation. A 10 turns potentiometer resistor is used as sensor for each side of flipper.

The EZ-Compass-3 module is used for robot navigation. It is a low cost advanced pitch / roll compensated compass / magnetometer system. This module not only outputs the azimuth but sends the dual axis tilt of pitch and roll and

temperature data over the standard RS 232 interface [15]. The data of this module is calculated with data from encoders for plotting the route of robot movement. Due to a strong metal object or magnetic anomaly affects to the module so the module should be placed as far as possible from the source of that anomaly. In this case we installed it at the top of robot body and place in the plastic box.

Laser Range Finder: A Hokuyo URG04-LX has been used [16]. It has an angular field of view of 240 degree and angular resolution of 0.36 degree. The range accuracy is ± 10 mm.

V. SOFTWARE SYSTEM

The software for this rescue robot can be divided into two parts as the software onboard the robot and the software on the operator station.

A. Onboard Software

For onboard software, we developed with C++. This software interfaces between the operator station software and the robot by receiving operator's command to control all robot functions, whereas gathering all sensors information and sending to the operator computer via Wi-Fi.

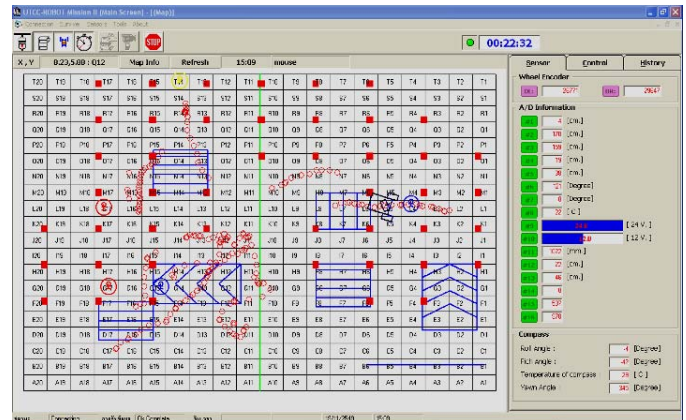

Fig. 9 Graphic User Interface (GUI) of robot controlling which shows the route of robot traveling in the competition arena (left) and information from sensors (right)

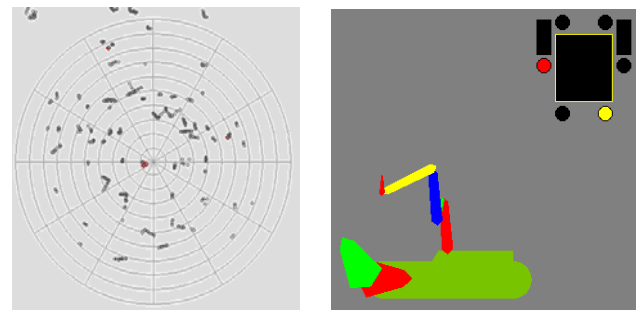

Fig. 10 The obstacle map from laser range finder (left) and GUI of robot's mechanical arm controlling (right)

B. Operator Station Software

For the operator station software, the visual basic is coded in order to process and display the sensors data from the robot and plot the victim access route and its location. The numbers of pulses counted by odometer sensors and the compass data are computed to plot the robot pose and the victim access route as shown in Fig. 9. However because of track wheels and movement slipping, the moving route of robot on the map may not be accurate. So we need to update the robot position from time to time with known landmarks such as poles or stairs. The mapping algorithm is designed base on a Grid based particle filter SLAM algorithm [17], which computes the data from LRF and plot the obstacle map as in the left of Fig. 10.

Moreover, the operator software also has the graphical user interface for controlling and monitoring the movement of the 5-joint mechanical arm as shown on the right in Fig. 10. We use the method of determining tip position in 2D coordinating system to control the movement of this mechanical arm. The user friendly control and monitor GUI is developed for easier usage. By clicking the determined target point or dragging the tip of the mechanical arm on screen to the desired target, the robot will move its arm to the pose as seen on the GUI screen. The angles of each joint are calculated and sent to all joint servos simultaneously in order to move the mechanical arm to the desired position. The operator can also use the joystick to control the movement of mechanical arm and the locomotion of the robot.



Fig. 11 CEO Mission II rescue robot testing under various conditions



Fig. 12 Final version of the CEO Mission II rescue robot

VI. TESTING RESULTS AND DISCUSSION

The CEO Mission II rescue robot were built as design and tested under various conditions such as climbing up/down stairs, looking over obstacles, searching for victim in the vehicle and move on the rough terrain. All testing results are satisfied as shown in Fig. 11. For better climbing up/down stairs, we attached the pointed supporting wheel at the back of the robot. And for better crossing the rough terrain, we attached the cone shape wheel cover to the two back wheels as in Fig. 4 and Fig. 12.

VII. CONCLUSIONS AND FUTURE WORK

The CEO Mission II rescue robot was designed and implemented. The rescue robotic system with track wheel type and double front flippers has been briefly described. Its performances were observed to be excellent in unstructured environments and successfully climb up/down the stairs. The development of this rescue robot can be adapted to fit many other applications easily by changing the top part of the robot. Further research may be made on better mapping algorithms. Finally, CEO Mission II won the 1st runner up award and the best technique award from Thailand Rescue Robot Championship 2006.

REFERENCES

- [1] A. Birk and S. Carpin, "Rescue robotics – a crucial milestone on th road to autonomous systems," *Advanced Robotics Journal*, vol. 20, J. Peters, Ed. New York: McGraw-Hill, 1964, pp. 15–64.
- [2] A. Davids, "Urban search and rescue robots: from tragedy to technology," *Intelligent Systems, IEEE [see also IEEE Intelligent Systems and Their Applications]*, vol. 17, no. 2, 2002, pp. 81-83.
- [3] Masaru Shimizu, "Tiny Seekers Team (Japan)" *RoboCup Rescue Robot League Competition*, Osaka, Japan, July 2005.
- [4] Hideyuki Tsukagoshi, Masashi Sasaki, Ato Kitagawa and Takahiro Tanaka, "Numerical Analysis and Design for a Higher Jumping Rescue Robot Using a Pneumatic Cylinder", *Journal of Mechanical Design*, vol. 127, Issue 2, March 2005, pp. 308-314.

- [5] Amon Tunwannarux, Supanunt Hirunyaphisuthikul, "Design Features and Characteristics of a Rescue Robot", *International Symposium on Communications and Information Technologies*, October 2005, pp.1047-1051.
- [6] F. Hardarsson, "Locomotion for difficult terrain," Mechatronics Lab., Dept. of Machine Design, Tech. Rep.,1997.
- [7] J. Y. Wong, *Theory of Ground Vehicle, 3rd edition*. John Wiley and Sons, Inc., 2001, ch.4.5.
- [8] A. Kleiner, B. Steder, C. Dornhege, D. Meyer-Delius, J. Prediger, J. Stueckler, K. Glogowski, M. Thurner, M. Luber, M. Schnell, R. Kuemmerle, T. Burk, T. Brauer, and B. Nebel, "Robocup rescue – robot league team rescuerobots freiburg (germany)," in *RoboCup 2005: Robot Soccer World Cup IX*, ser. Lecture Notes in Artificial Intelligence (LNAI), I. Noda, A. Jacoff, A. Bredendfeld, and Y. Takahashi, Eds. Springer, 2006.
- [9] W. Lee, S. Kang, S. Lee, and C. Park, " Robocuprescue- robot league team ROBHAZ-DT3 (south Korea)," in *RoboCup 2005: Robot Soccer World Cup IX*, ser. Lecture Notes in Artificial Intelligence (LNAI), I. Noda, A. Jacoff, A. Bredendfeld, and Y. Takahashi, Eds. Springer, 2006.
- [10] M. W. Kadous, S. Kodagoda, J. Paxman, M. Ryan, C. Sammut, R. Sheh, J. V. Miro, and J. Zaitseff, " Robocuprescue- robot league team CASualty (Australia)," in *RoboCup 2005: Robot Soccer World Cup IX*, ser. Lecture Notes in Artificial Intelligence (LNAI), I. Noda, A. Jacoff, A. Bredendfeld, and Y. Takahashi, Eds. Springer, 2006.
- [11] T. Tsubouchi and A. Tanaka, " Robocuprescue- robot league team Intelligent Robot Laboratory (Japan)," in *RoboCup 2005: Robot Soccer World Cup IX*, ser. Lecture Notes in Artificial Intelligence (LNAI), I. Noda, A. Jacoff, A. Bredendfeld, and Y. Takahashi, Eds. Springer, 2006.
- [12] A. Birk, K. Pathak, S. Schwertfeger and W. Chonnaparamutt, "*The IUB Rugbot: an intelligent, rugged mobile robot for search and rescue operations*", International Workshop on Safety, Security, and Rescue Robotics (SSRR), IEEE Press, 2006.
- [13] Sharp Corp., *Distance measuring sensors notes*, 2003.
- [14] Raytek Corp., *Thermalert manual*. Available: <http://www.raytek.com>
- [15] AOS Inc., *EZ Compass-3 manual*. Available: <http://www.aositilt.com>
- [16] Hokuyo, *Scanning Laser Range Finder datasheet*. Available: <http://www.hokuyo-aut.jp/products/urg/urg.htm>, 2006.
- [17] G. Grisetti, C. Stachniss, and W. Burgard., "Improving Grid-based SLAM with Rao-Blackwellized Particle Filters by Adaptive Proposals and Selective Resampling.", *Proc. of the IEEE Int. Conf. on Robotics and Automation*, 2005. Available: <http://www.informatik.uni-freiburg.de/stachnis/research/rbpfmapper>