

Application of Artificial Neural Networks for Prediction of Natural Convection Heat Transfer from a confined Horizontal Elliptic Tube

Mohsen Hayati, Tooraj Yousefi, Mehdi Ashjaee, Abdolsamad Hamidi, and Yazdan Shirvany

Abstract—In this paper, simulation of natural convection heat transfer from a confined isothermal horizontal elliptic tube based on artificial neural network is presented. The experimental work with changing of all variables is time consuming and expensive and usually has problems associated with it. Experimental data used for the neural network was obtained by a Mach-Zehnder interferometer. In this study, various parameters have been used. Tube axis ratio, wall spacing and rayleigh number are inputs and average nusselt number is desired output. Multi-layer feedforward network was applied to simulate the steady condition of heat transfer rate distribution in described geometry. Results of network have excellent agreement with experimental data. Therefore, the network is used to predict the unseen data points within the range of experimental results.

Keywords—Neural network, Back propagation, Nusselt number, Rayleigh number, Elliptic tube.

I. INTRODUCTION

THE study of heat transfer is one of the most important problems in engineering applications. For example, in electrical engineering, in places like transmission line and wires that carry the current are located compactly, if their distance are not chosen correctly, the heat generated by them has adverse effect on their actions. It causes melting of their isolation and undesirable effects may occur. Moreover, a wide range of practical applications involve the analysis of heat transfer, for example in heat exchangers, reactors etc. [1]. The study of heat transfer around heated elliptic tube of different cross section confined between two walls is essential for a better thermal design of such heat exchangers. Heat transfer around circular cylinder as a special case of elliptic tube has been studied widely [2-7]. To enhance the heat transfer rate around elliptic tube more research has to be done.

Manuscript received March 11, 2007.

M. Hayati is with Electrical Engineering Department, Faculty of Engineering, Razi University, Kermanshah, Iran (e-mail: hayati@razi.ac.ir).

T. Yousefi is with Mechanical Engineering Department, Faculty of Engineering, Razi University, Kermanshah, Iran (e-mail: Yousefi@razi.ac.ir).

M. Ashjaee is with Mechanical Engineering, Department of Tehran University, Tehran-Iran.

A. Hamidi is M.E student in Electrical Engineering Department, Faculty of Engineering, Razi University, Kermanshah, Iran.

Y. Shirvany is M.E student in Electrical Engineering Department, Faculty of Engineering, Razi University, Kermanshah, Iran.

Fieg and Roetzel showed that the elliptical deformation increases heat transfer coefficient during their analytical investigation on laminar film condensation on inclined elliptical tube [8]. A. O. Elsayed et. al., studied free convection from a constant heat flux elliptic tube experimentally [9]. To enhance heat transfer from the tube surface, a technique was employed to confine the tube between two adiabatic walls [10]. The work done so far[1], they developed an individual ANN network for each access ratio, thereby for each axis ratio an ANN is needed as it is time consuming and computational speed is being reduced. In order to overcome such problem that is, to have only one ANN for all axis ratio, a model is developed in such a way that axis ratio will be considered as one of the input to the network. The objective of this work is to develop an artificial neural network (ANN) model to predict the average nusselt number for heat transfer from elliptic tube cross sections confined between two adiabatic walls.

NOMENCLATURE

| | |
|----------------|--|
| a | major axis(m) |
| AAD | Average Absolute Deviation |
| b | minor axis(m) |
| a' | output of each neuron |
| b' | bias vector of each neuron |
| f | transfer function |
| H | wall length |
| H1 | Distance from top to center of tube |
| H2 | Distance from bottom to center of tube |
| LM | Levenberg-Marquardt |
| n | transfer function input |
| N_p | number of point |
| Nu | average Nusselt number |
| p | input vector |
| Ra | Rayleigh number |
| t | wall spacing (m) |
| ΔNU | relative error (Nusselt difference) |
| $\% \Delta NU$ | error deviation (Nusselt difference in percentage) |
| W | weight vector |
| Y | target activation of the output layer |
| W' | wall diameter |
| Subscript | |
| exp | experimental |
| pred | predicted |
| R | number of elements in input |

II. ARTIFICIAL NEURAL NETWORK

The artificial neural networks are strong tools for prediction and simulation in engineering applications. In this study, the average Nusselt number is adopted as a function of three variables namely:

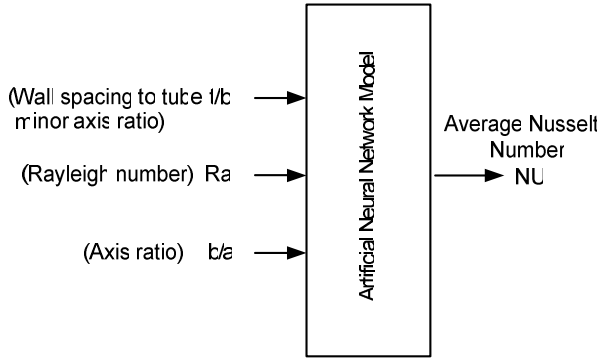

Fig. 1 Input-output schematic of system

- i- t/b , wall spacing to tube minor axis ratio
- ii- Ra , Rayleigh number
- iii- b/a , Axis ratio

Therefore an ANN model as shown in Fig. 1 is developed with tube axis ratio, distance from the center of tube and rayleigh number as inputs and average nusselt number as desired output.

A. Computational Intelligence Model

In this study, we use one model of neural networks i.e., feedforward multi-layer perceptron (MLP) network, which is selected among the main neural network architectures used in engineering. The basis of the model is neuron structure as shown in Fig. 2, where R is the number of elements in input vector. Each input is weighted with an appropriate w . The sum of the weighted inputs and the bias, forms the input to the transfer function f . Neurons may use any differentiable transfer function f to generate their output. Some of the transfer functions are shown in Fig. 3 [11].

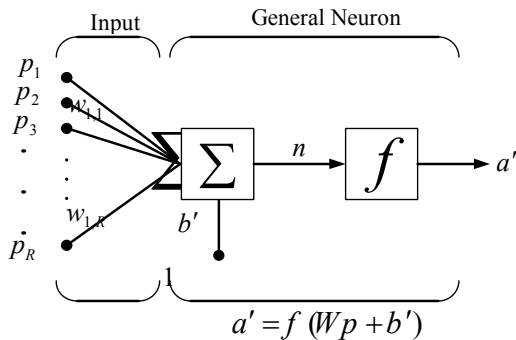
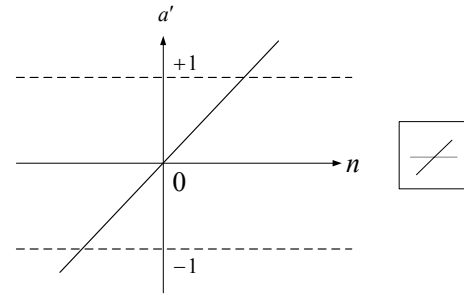

Fig. 2 An elementary neuron with R inputs

Artificial Neural Networks (ANNs) consist of a great number of processing elements (neurons), connected to each

other. The strengths of the connections are called weights. A feedforward multilayer network is commonly used to model physical systems. It consists of a layer of input neurons, a layer of output neurons and one or more hidden layers.



$a' = \text{purelin}(n)$
Linear Transfer Function

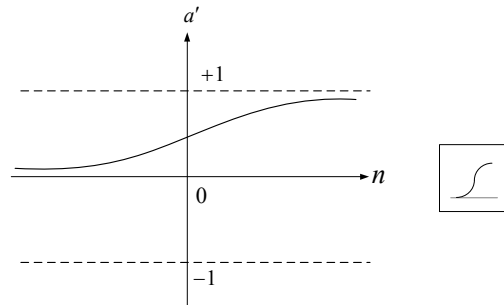

$a' = \text{logsig}(n)$
Log – sigmoid Transfer Function

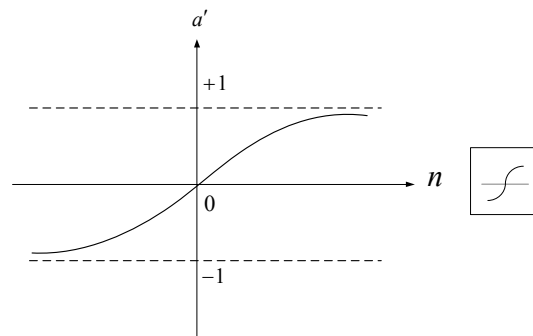

$a' = \text{tansig}(n)$
Tan-Sigmoid Transfer Function

Fig. 3 Three type of transfer function

B. Feedforward Network

Feedforward networks often have one or more hidden layers with sigmoid transfer function followed by an output layer with linear transfer function. Multiple layers of neurons with nonlinear transfer functions allow the network to learn nonlinear and linear relationships between input and output vectors. For multiple-layer networks, we use number of layers to determine the superscript on the weight matrices. The appropriate notation is used in the four-layer network as shown

in Fig. 4. This network can be used as a general function approximator. It can approximate any function with a finite number of discontinuities, arbitrarily well, given sufficient neurons in the hidden layer [11]. The network configuration for our study is shown in Fig. 4 where the transfer functions for layers are tansig/ tansig / tansig/ purelin respectively. The network was trained with LM algorithm [12].

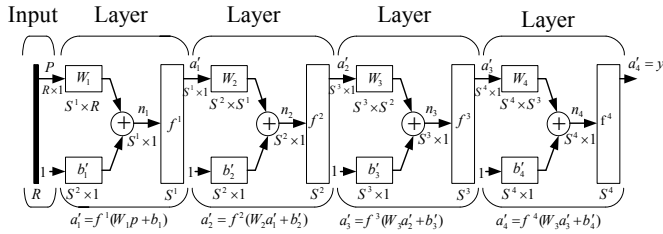

Fig. 4 Four-layer network

III. EXPERIMENTAL SETUP

A model of elliptic tube confined between two adiabatic walls is shown in Fig. 5. The tested tubes were made of aluminum with the length of 160 mm and major and minor axes of them were chosen so that the same periphery could be obtained. The dimensions of walls were 56×20×160mm and the tube was placed symmetrically between the two walls. Heating wire was placed inside the tube and it was heated using a variable power supply. The Mach-Zehnder Interferometer used in the experiment is the same as used by Ashjaee et. al., [10]. The details of the Mach-Zehnder Interferometer setup and the data reduction procedure are fully explained in ref. [10] and are not described here, because of not being the purpose of the present work.

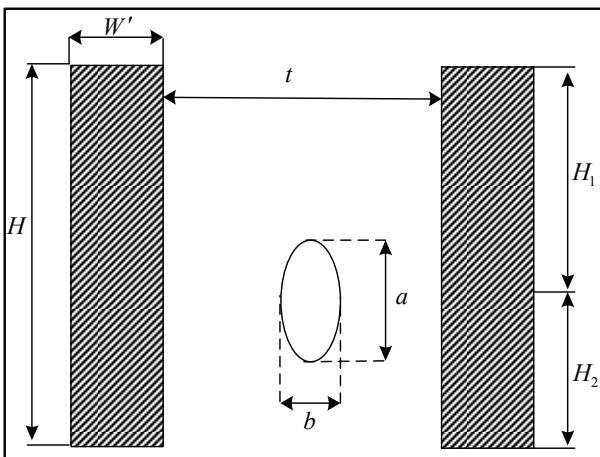

Fig. 5 Schematic diagram of the problem (H1 and H2 are fixed and equal to 32mm and 24mm respectively)

Since the experimental data points are obtained from the work of Ashjaee et. al., and a good agreement between the experimental results and the results of the other researches have been observed, therefore comparisons are not made here again.

IV. SIMULATION WITH ANN

The artificial neural networks are strong tools for prediction and simulation in engineering applications. In this study, the artificial neural network model is developed for prediction of average nusselt number from an isothermal horizontal cylinder of elliptical cross section confined between two adiabatic walls. As mentioned before the experiment needs a considerable amount of time to get accurate results. In this study, the average Nusselt number is adopted as a function of three variables namely:

- i- t/b , wall spacing to tube minor axis ratio
- ii- Ra , Rayleigh number
- iii- b/a , Axis ratio

The aim is to arrive at a unique set of weights and biases that are capable for qualified prediction of average Nusselt number. With a better set up training parameters, it is possible to approximate the output with high accuracy. The speed of learning is governed by the learning rate. Learning rate affects the convergence speed and stability of the weights and biases during learning [1,10]. The larger the learning rate, the bigger the step. If the learning rate is made too large, the algorithm becomes unstable. If the learning rate is set too small, the algorithm takes a long time to converge [1,10]. The training function is a function used for adjusting weights and biases to minimize the performance function. The number of iterations was considered to reach the acceptable performance or error is determined with epoch number [1]. The optimal structures for developed MLP neural network for obtaining minimum prediction error is shown in Table I.

TABLE I
OPTIMAL ARCHITECTURE AND SPECIFICATION OF THE GENERATED ANN

| | |
|---|----------|
| Neural Network | MLP |
| No. of hidden layers | 2 |
| No. of neurons in the input layer | 5 |
| No. of neurons in the first hidden layer | 8 |
| No. of neurons in the second hidden layer | 18 |
| No. of neurons in the output layer | 1 |
| Learning rate | 0.5 |
| Number of epochs | 1000 |
| Adaption learning function | train lm |
| Training error | 0.00001 |

The error difference (ΔNU) and error deviation ($\Delta NU\%$) for the average nusselt number are evaluated as

$$\Delta NU = NU_{exp} - NU_{pred} \tag{1}$$

$$\Delta NU \% = 100 \times \frac{NU_{exp} - NU_{pred}}{NU_{exp}} \tag{2}$$

where ‘exp’ and ‘pred’ stand for experimental and predicted values, respectively. Also, the Average Absolute Deviation (AAD %) is evaluated as:

$$AAD \% = \frac{1}{N_p} \sum_{i=1}^{N_p} |\Delta NU \%|_i \quad (3)$$

where N_p is the number of points. The maximum and minimum of $\Delta Nu\%$ along with AAD % are shown in Table II.

TABLE II
THE MAXIMUM AND MINIMUM OF $|\Delta NU\%|$ AND AAD %

| Data | TRAIN | TEST |
|---------------------|-------------|-------------|
| MAX $ \Delta NU\% $ | 0.324120455 | 1.881630374 |
| MIN $ \Delta NU\% $ | 0.00000000 | 0.00997009 |
| AAD% | 0.0510 | 0.5826 |

It is observed from Table II that the maximum deviation for the train set is less than 0.325% and the maximum deviation for the test set is less than 1.89%. It indicates that there is a good agreement between experimental and predicted data. The Comparison of Experimental average nusselt number (Nu exp.) with predicted average nusselt number (Nu pre.), error difference, error deviation for test data (unseen data) are shown in Table III. The result show that the predicted values are in good agreement with experimental data. The comparison between experimental and predicted values for train and test are shown in Figs. 6 and 7 respectively. These figures also shows the predicted values are very close to experimental values with least error.

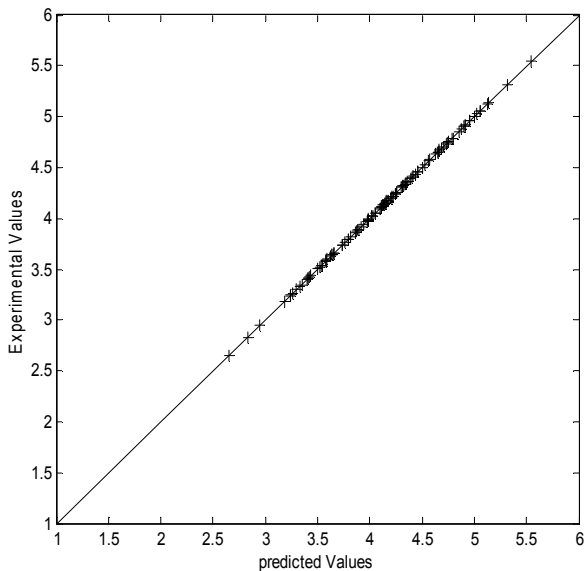

Fig. 6 The comparison between experimental and predicted values for training

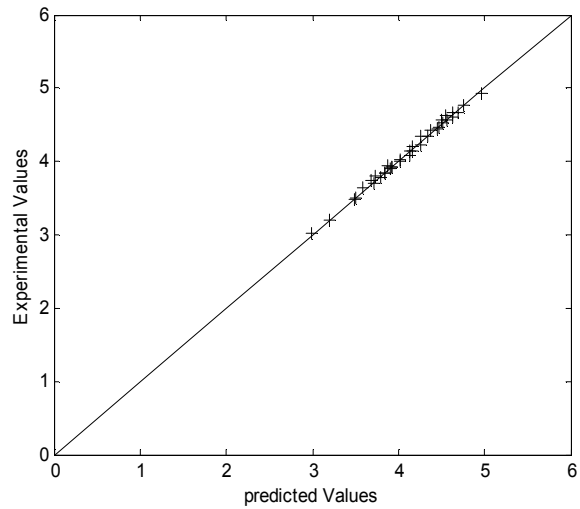

Fig. 7 The comparison between experimental and predicted values for testing

TABLE III
COMPARISON OF EXPERIMENTAL AVERAGE NUSSELT (NU EXP.) WITH PREDICTED AVERAGE NUSSELT NUMBER(NU PRE.), ERROR DIFFERENCE, ERROR DEVIATION

| ANN inputs | | | ANN output | | | |
|------------|------|------|------------|--------|-------------|---------------|
| t/b | Ra | b/a | Nu.pre | Nu.exp | ΔNU | $\Delta Nu\%$ |
| 1.91 | 2250 | 0.53 | 3.7886 | 3.7984 | 0.0098 | 0.25800337 |
| 2.3 | 2250 | 0.53 | 4.1456 | 4.1666 | 0.021 | 0.504008064 |
| 2.67 | 2250 | 0.53 | 4.6575 | 4.6328 | -0.0247 | 0.533154896 |
| 3.17 | 2250 | 0.53 | 4.6749 | 4.6943 | 0.0194 | 0.413267154 |
| 3.8 | 2250 | 0.53 | 4.559 | 4.5596 | 0.0006 | 0.013159049 |
| 4.6 | 2250 | 0.53 | 4.4703 | 4.4618 | -0.0085 | 0.190506074 |
| 6.12 | 2250 | 0.53 | 4.2322 | 4.254 | 0.0218 | 0.512458862 |
| 8 | 2250 | 0.53 | 4.1447 | 4.1322 | -0.0125 | 0.302502299 |
| 13 | 2250 | 0.53 | 3.8965 | 3.9138 | 0.0173 | 0.442025653 |
| 1.5923 | 1500 | 0.67 | 3.2 | 3.202 | 0.002 | 0.062460962 |
| 1.9108 | 1500 | 0.67 | 3.9159 | 3.917 | 0.0011 | 0.028082716 |
| 2.1401 | 1500 | 0.67 | 4.2055 | 4.164 | -0.0415 | 0.996637848 |
| 2.4203 | 1500 | 0.67 | 4.4415 | 4.454 | 0.0125 | 0.28064661 |
| 3.1847 | 1500 | 0.67 | 4.0931 | 4.125 | 0.0319 | 0.773333333 |
| 5.0955 | 1500 | 0.67 | 4.0266 | 4.018 | -0.0086 | 0.214036834 |
| 7.6433 | 1500 | 0.67 | 3.7036 | 3.706 | 0.0024 | 0.064759849 |
| 10.191 | 1500 | 0.67 | 3.5031 | 3.5056 | 0.0025 | 0.071314468 |
| 16.5603 | 1500 | 0.67 | 3.4819 | 3.497 | 0.0151 | 0.431798685 |
| 1.5923 | 2250 | 0.67 | 3.8446 | 3.848 | 0.0034 | 0.088357588 |
| 1.9108 | 2250 | 0.67 | 4.6114 | 4.622 | 0.0106 | 0.229337949 |
| 2.1401 | 2250 | 0.67 | 4.9308 | 4.962 | 0.0312 | 0.628778718 |
| 2.4203 | 2250 | 0.67 | 4.7688 | 4.755 | -0.0138 | 0.29022082 |
| 3.1847 | 2250 | 0.67 | 4.5178 | 4.522 | 0.0042 | 0.092879257 |
| 5.0955 | 2250 | 0.67 | 4.3347 | 4.336 | 0.0013 | 0.02998155 |
| 7.6433 | 2250 | 0.67 | 4.0124 | 4.012 | -0.0004 | 0.00997009 |
| 10.191 | 2250 | 0.67 | 3.9256 | 3.926 | 0.0004 | 0.010188487 |
| 16.5603 | 2250 | 0.67 | 3.8415 | 3.84 | -0.0015 | 0.0390625 |
| 1.4164 | 1750 | 0.8 | 3.0164 | 2.9965 | -0.0199 | 0.664108126 |
| 1.6997 | 1750 | 0.8 | 4.3435 | 4.2649 | -0.0786 | 1.842950597 |
| 1.9036 | 1750 | 0.8 | 4.6352 | 4.5506 | -0.0846 | 1.859095504 |
| 2.1529 | 1750 | 0.8 | 4.5641 | 4.5052 | -0.0589 | 1.307378141 |
| 2.8328 | 1750 | 0.8 | 4.4163 | 4.3761 | -0.0402 | 0.918626174 |
| 4.5325 | 1750 | 0.8 | 3.9378 | 3.8792 | -0.0586 | 1.510620747 |
| 6.7988 | 1750 | 0.8 | 3.7934 | 3.7273 | -0.0661 | 1.773401658 |
| 9.0651 | 1750 | 0.8 | 3.7405 | 3.6777 | -0.0628 | 1.707588982 |
| 14.7308 | 1750 | 0.8 | 3.6494 | 3.582 | -0.0674 | 1.881630374 |

Also, the comparison between average Nusselt numbers obtained from experiment and those predicted with neural network for tested data, as a function of t/b ratio for some selected Rayleigh numbers for each $b/a=0.53, 0.67, 0.8$, are shown in Fig. 8. It is observed from Fig. 8, that the average Nusselt number increases with the increase of the Rayleigh number for each wall spacing. For a constant Rayleigh number, there is optimum wall spacing, where the heat transfer from the elliptic cylinder is maximum. As the wall spacing increases from its optimum value, the average Nusselt number decreases and approaches to the value of average Nusselt number for a tube in infinite medium. Also, for each Rayleigh number, decrease of the wall spacing from its optimum value causes a sharp decrease in the average Nusselt number. On the other hand, Fig. 8 shows that results obtained from neural network have fitted well with the results of experiment [1,10].

The results showed that the model can be used in this problem for prediction of average Nusselt number which is important in free convection application.

V. CONCLUSION

This study was conducted to demonstrate the capability of the artificial intelligence techniques for the prediction of free convection heat transfer coefficient. A neural network model has been developed to predict the average nusselt number for heat transfer from elliptic tube cross sections confined between two adiabatic walls. The network was trained using experimental data. The maximum absolute error for trained and tested values are 0.324% and 1.881% respectively and Average Absolute Deviation (AAD %) are 0.0510% and 0.5826% for train and tested data respectively. The results shows predicted values are very close to experimental values.

REFERENCES

- [1] M. Ashjaee, R. Afzali., M. Niknami., M. Amiri., T. Yousefi, Neural network analysis of free connection around isothermal elliptic tube, *8th Biennial ASME Conference on Engineering Systems Design and Analysis*, Torino, Italy, July 4-7, 2006.
- [2] T.H. Kuehn, R.J. Goldstein, Numerical solution to the Navier-Stokes equations for laminar natural convection about a horizontal isothermal circular cylinder, *Intl. J. Heat Mass Transfer*, vol. 23, 1980, pp. 971-979.
- [3] T. Saitoh, T.Sajiki, K. Maruhara, Bench mark solution to natural convection heat transfer problem around the horizontal circular cylinder, *Intl. J. Heat Mass Transfer*, vol. 36, 1993, pp. 1251- 1259.
- [4] V.T. Morgan, The overall convection heat transfer from smooth circular cylinders, *Advances in Heat Transfer*, vol. 11, 1975, pp.199-264.
- [5] S.W.Churchill, H.H.S. Chu, Correlating equations for laminar and turbulent free convection from a horizontal cylinder, *Intl. J. Heat Mass Transfer*, vol. 18, 1975, pp. 1049-1053.
- [6] H.M. Badr, Heat transfer buoyancy driven flow adjacent to a horizontal rod, *Intl. J. Heat Mass Transfer*, vol. 30, 1987, pp. 1997-2012.
- [7] R. Diez, M. Dolz, R. Belda, J.V. Herraes, M. Buendia, Free convection around a horizontal circular cylinder. A dimensional empirical equation, *Applied Scientific Research*, vol.46, 1989, pp. 365-378.

- [8] G. P. Fieg, W. Roetzel, Calculation of laminar film condensation in/on inclined elliptical tubes, *Intl. J. Heat Mass Transfer*, vol. 37, 1994, pp. 619-624.
- [9] A.O. Elsayed, E.Z. Ibrahim, S.A. Elsayed, Free from a constant heat flux Elliptic tube, *Energy Conservation and Management*, vol. 44, 2003, pp. 2445-2453, 2003.
- [10] M. Ashjaee, T. Yousefi, M. Amiri, Free convection heat transfer from a confined horizontal elliptic cylinder, accepted for publication in the *Journal of Heat Transfer Engineering*.
- [11] H. Demuth, M. Beale, Neural network toolbox for use with MATLAB.
- [12] M.T. Hagan, H.B. Demuth, M.H. Beale, *Neural network design*, PWS Publishing Company, Boston, Massachusetts, 1996.

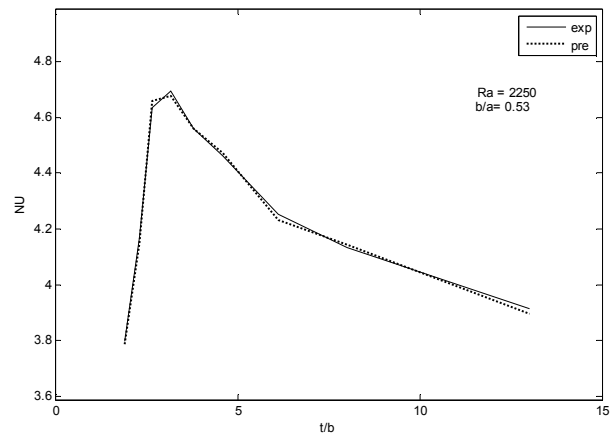

Fig. 8 (a) Comparison between experimental and predicted values for $b/a=0.53$

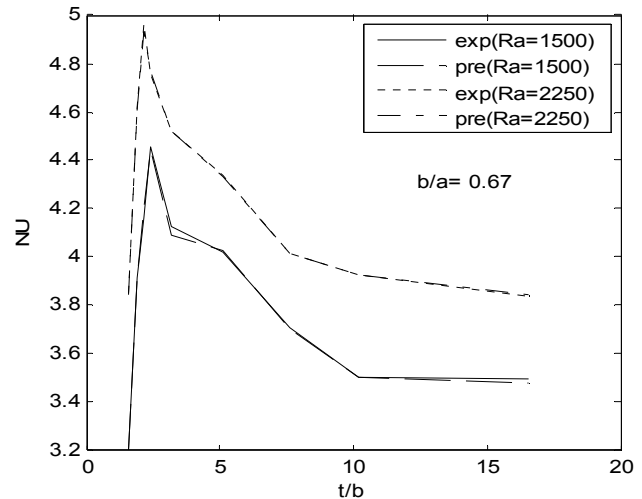

Fig. 8 (b) Comparison between experimental and predicted values for $b/a=0.67$

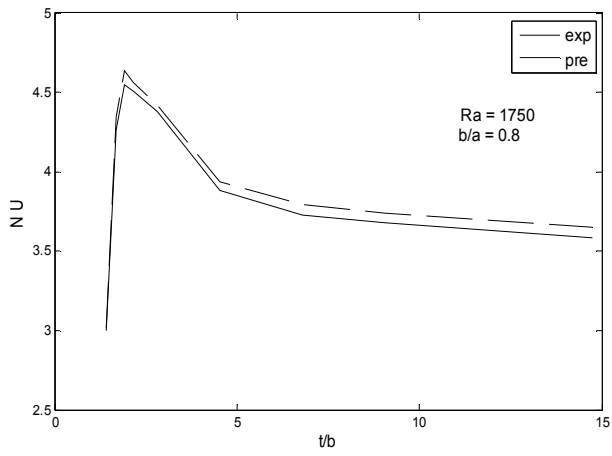

Fig. 8 (c) Comparison between experimental and predicted values for $b/a=0.8$