

Application of RP Technology with Polycarbonate Material for Wind Tunnel Model Fabrication

A. Ahmadi Nadooshan, S. Daneshmand, and C. Aghanajafi

Abstract—Traditionally, wind tunnel models are made of metal and are very expensive. In these years, everyone is looking for ways to do more with less. Under the right test conditions, a rapid prototype part could be tested in a wind tunnel. Using rapid prototype manufacturing techniques and materials in this way significantly reduces time and cost of production of wind tunnel models. This study was done of fused deposition modeling (FDM) and their ability to make components for wind tunnel models in a timely and cost effective manner. This paper discusses the application of wind tunnel model configuration constructed using FDM for transonic wind tunnel testing. A study was undertaken comparing a rapid prototyping model constructed of FDM Technologies using polycarbonate to that of a standard machined steel model. Testing covered the Mach range of Mach 0.3 to Mach 0.75 at an angle-of-attack range of -2° to $+12^\circ$. Results from this study show relatively good agreement between the two models and rapid prototyping Method reduces time and cost of production of wind tunnel models. It can be concluded from this study that wind tunnel models constructed using rapid prototyping method and materials can be used in wind tunnel testing for initial baseline aerodynamic database development.

Keywords—Polycarbonate, Fabrication, FDM, Model, Rapid Prototyping, Wind Tunnel.

I. INTRODUCTION

THE term rapid prototyping (RP) refers to a class of technologies that can automatically construct physical models from Computer-Aided Design (CAD) data. These "three dimensional printers" allow designers to quickly create tangible prototypes of their designs, rather than just two-dimensional pictures. Such models have numerous uses. They make excellent visual aids for communicating ideas with co-workers or customers [1]. In addition, prototypes can be used for design testing. For example, an aerospace engineer might mount a model airfoil in a wind tunnel to measure lift and

drag forces. Designers have always utilized prototypes; RP allows them to be made faster and less expensively [2]. In addition to prototypes, RP techniques can also be used to make tooling and even production-quality parts. Most prototypes require from three to seventy-two hours to build, depending on the size and complexity of the object. This may seem slow, but it is much faster than the weeks or months required to make a prototype by traditional means such as machining [3]. These dramatic time savings allow manufacturers to bring products to market faster and more cheaply. At least six different rapid prototyping techniques are commercially available, each with unique strengths. Because RP technologies are being increasingly used in non-prototyping applications, the techniques are often collectively referred to as solid free-form fabrication; computer automated manufacturing, or layered manufacturing. The latter term is particularly descriptive of the manufacturing process used by all commercial techniques [4]. Rapid prototyping is an "additive" process, combining layers of paper, wax, or plastic to create a solid object. In contrast, most machining processes (milling, drilling, grinding, etc.) are "subtractive" processes that remove material from a solid block. RP's additive nature allows it to create objects with complicated internal features that cannot be manufactured by other means [5]. The precursor study wind tunnel model was constructed using the fused deposition method (FDM). RP model constructed using FDM with polycarbonate as a material. AISI 1045H (CK45) was chosen as the material for the machined metal model. Testing covered the Mach range of Mach 0.3 to Mach 0.75 at an angle-of-attack range of -2° to $+12^\circ$. As it can be seen from the study results: 1) could FDM method with polycarbonate as a material produce a detailed scale model within required dimensional tolerances? 2) What is the cost and time requirements for the FDM method as compared to a standard machined metal model? Results from this study show relatively good agreement between the two models and rapid prototyping Method reduces time and cost of production of wind tunnel models.

II. NOMENCLATURE

α : angle-of-attack
 C_A : axial force coefficient
 C_N : normal force coefficient
 C_M : pitching moment coefficient

Manuscript received September 11, 2007.

A. Ahmadi Nadooshan is with the Mechanical Engineering Department, Islamic azad university, Majlessi branch, Isfahan, Iran (e-mail: afshin_ahmadina@yahoo.com).

S. Daneshmand is with the Mechanical Engineering Department, Islamic azad university, Majlessi branch, Isfahan, Iran (e-mail : Saeed_Daneshmand@Yahoo.com).

C. Aghanajafi is with the Mechanical Engineering Department, University of K.N.T., Tehran, Iran (e-mail: s_aghanajafi@yahoo.com).

FDM: fused deposition modeling

III. FUSED DEPOSITION MODELING (FDM)

FDM Process using molten plastics or wax extruded by a nozzle that traces the parts cross sectional geometry layer by layer. FDM creates tough parts that are ideal for functional usage. The FDM rapid prototyping process is akin to using a hot glue gun to make parts [6]. An FDM machine consists of the following parts a build platform; filament feed devices, heated extrusion nozzles and a nozzle control apparatus. The whole system is contained within a heated environment to reduce the amount of energy needed to melt the filament at the nozzle. The FDM process feeds filaments of build material and support material to heated nozzles. These nozzles are used to lay down molten filaments of build and support materials in the desired cross sectional geometries. Once the first cross section is completed the build platform is lowered one layer thickness and the next cross section is printed [7]. This process is continued until the part is completed (Fig. 1).

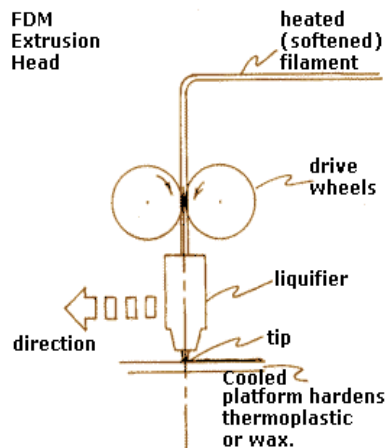

Fig. 1 Fused Deposition Modeling (FDM) rapid prototyping process

IV. MODEL CONSTRUCTION

The RP processes were fused deposition modeling (FDM) using material of Polycarbonate (PC) plastic. Steel (ASTM A284) was chosen as the material for the machined metal model. The fused deposition modeling involves the layering of molten beaded PC plastic material via a movable nozzle in 0.178 mm thick layers. Polycarbonate PC is an actual industrial-grade thermoplastic that is impact-resistant and structurally strong. Polycarbonate parts produced with FDM are dimensionally stable and will not shrink, warp, or absorb moisture. This high-performance engineering material can handle greater forces and loads than ABS material and is ideal for functional prototypes and end-use parts [8]. FDM Models can be produced within an accuracy of $\pm .127$ mm up to 127 mm. Accuracy on models greater than 127 mm is $\pm .0015$ mm per millimeter. Fig. 2 show the model tested FDM .The

material properties of ASTM A284 (St37) and PC are shown in Table I and Table II [8].

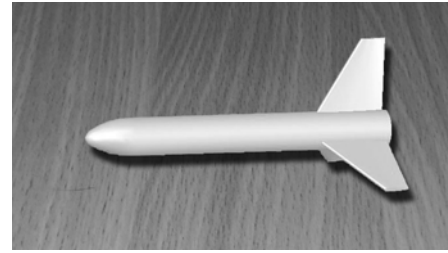

Fig. 2 Model tested FDM

TABLE I
MATERIAL PROPERTIES OF ASTM A284

Mechanical Properties	Units	ASTM A284 (St 37)
Tensile Strength, Ultimate	Mpa	415
Tensile Strength, Yield	Mpa	205
Elongation at Break	Percent	21

TABLE II
MATERIAL PROPERTIES OF POLYCARBONATE (PC)

Mechanical properties	Units	Test Method	PC
Tensile Strength	Mpa	ASTM D638	52
Tensile Modulus	Mpa	ASTM D638	1,744
Tensile Elongation	Percent	ASTM D638	5
Flexural Strength	Mpa	ASTM D790	82
Flexural Modulus	Mpa	ASTM D790	2,193

V. MODEL CONFIGURATION

A wing-body-tail configuration was chosen for this test. First, this configuration would indicate possible deflections in the wings or tail due to loads and whether the manufacturing accuracy of the airfoil sections would adversely affect the aerodynamic data that resulted during testing. Secondly, will the model be able to withstand the starting, stopping and operating loads in a blow down wind tunnel [9]. A preliminary computer aided design (CAD) file was available for RP model design and fabrication. This Geometry provided a basis for comparisons between RP models and machined metal models. The model configuration is shown in Fig. 3. The reference dimensions for this configuration are shown in Table III.

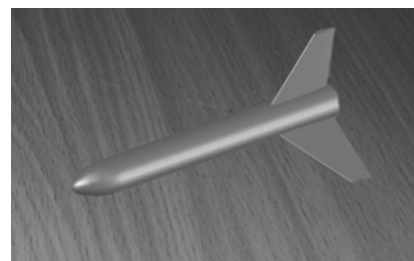

Fig. 3 Wing-body-tail configuration

TABLE III
REFERENCE DIMENSIONS

reference dimension	Units	dimensions
Length (L_{ref})	mm	200
area (S_{ref})	cm ²	48
moment point (X_{MRP})	mm aft of nose	140

VI. WIND TUNNEL OPERATING CHARACTERISTICS

Engineers for verifying his calculations when a model is prepared, carry out the aerodynamic tests that start from wind tunnel and end to ambient conditions. Forces and moments measurement is the most purpose of test in the wind tunnels [10]. The Transonic Wind Tunnel is an intermittent blow down tunnel, which operates by high- pressure air flowing from storage to either vacuum or atmosphere conditions. Mach numbers between 0.3 and 0.75 are obtained by using a controllable diffuser. Downstream of the test section is a hydraulically controlled pitch sector that provides the capability of testing angles-of-attack ranging from -2 to +12 degrees during each run. The diffuser section has movable floor and ceiling panels, which are the primary means of controlling the subsonic Mach numbers. As an intermittent blow down-type tunnel, experiences large starting and stopping loads. This, along with the high dynamic pressures encountered through the Mach range, requires models that can stand up to these loads.

Table IV shown lists the relation between Mach number, dynamic pressure, and Reynolds number per meter.

TABLE IV
WIND TUNNEL OPERATING CONDITIONS

Mach number	Dynamic pressure	Reynolds number
0.3	8.96 kPa	9.18×10^4
0.5	25.53	12.04×10^4
0.75	30.42	15.52×10^4

VII. AERODYNAMIC AXIS SYSTEM

A wind tunnel test over a range of Mach numbers from 0.3 to 0.75 was undertaken to determine the aerodynamic characteristics of the models at 4 selected numbers for the precursor study. These Mach numbers were 0.3, 0.5 and 0.75. Both models were tested at angle-of-attack ranges from -2 degrees to +12 degrees at zero sideslip. The reference aerodynamic axis system and reference parameters for the precursor study are shown in Fig. 4 [11].

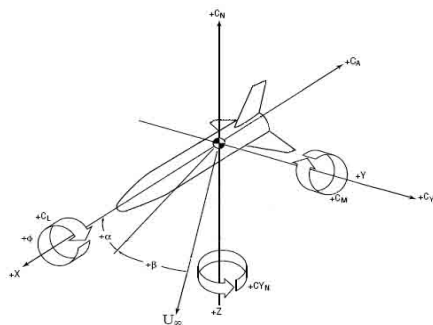

Fig. 4 Wing-body aerodynamic axis system

VIII. RESULTS

Coefficients of normal force, axial force, pitching moment, and lift over drag are shown at each of these Mach numbers. Testing was done over the Mach range of 0.3 to 0.75 at 4 selected numbers for the precursor study. These Mach numbers were 0.3, 0.5 and 0.75. The longitudinal aerodynamic data show some small discrepancies between the two model types. The study showed that between Mach numbers of 0.3 to 0.75, the longitudinal aerodynamic data showed very good agreement between the metal model and FDM model up to about 10 degrees angle-of-attack when it started to diverge due to assumed FDM model surface bending under higher loading (Figs. 5 through 13). The greatest difference in the aerodynamic data between the models at Mach numbers of 0.3 to 0.75 was in total axial force. All the models showed good agreement in pitching moment (Figs. 6, 9 and 12). In general, it can be said that RP model longitudinal aerodynamic data showed a slight divergence at higher angles-of attack when compared to the metal model data. The longitudinal aerodynamic data or data in the pitch plane showed approximately a 3-degree shift in the data between the RP and metal model for the normal force (Figs.5, 8, and 11), and approximately a 1-degree data shift for the pitching moment (Figs. 6, 9 and 12). The total axial force was slightly lower for the RP model than the metal model (Figs. 7, 10 and 13).

IX. COST AND TIME

The cost and time requirements for the FDM model and the steel model are shown in Table V. The FDM model for this test cost about \$650 and took between 1 and 2 weeks to construct, while the steel model cost about \$1300 and took one month to design and fabricate.

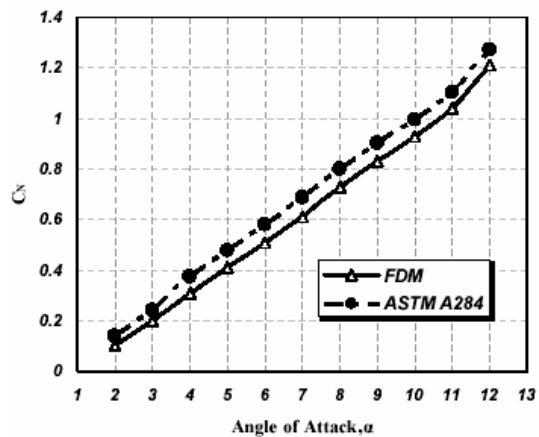

Fig. 5 Comparison of normal force coefficient at Mach 0.3

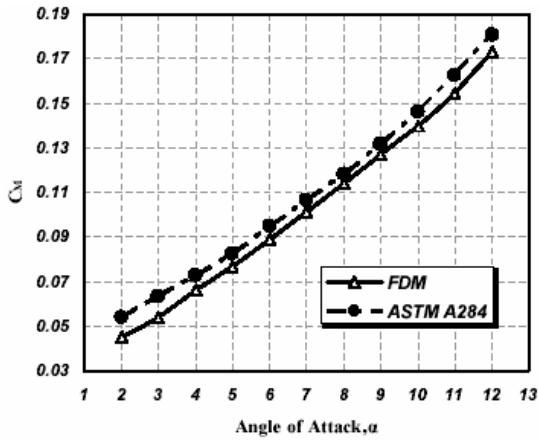

Fig. 6 Comparison of pitching moment coefficient at Mach 0.3

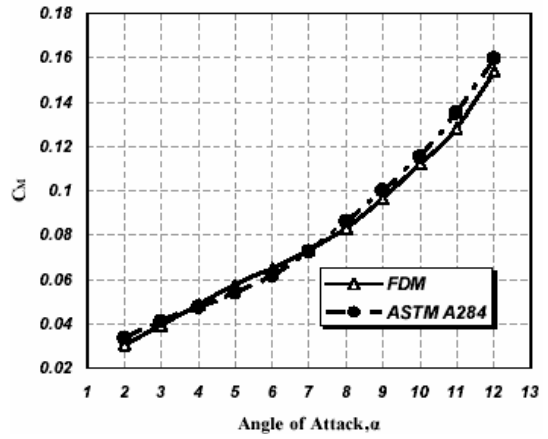

Fig. 9 Comparison of pitching moment coefficient at Mach 0.5

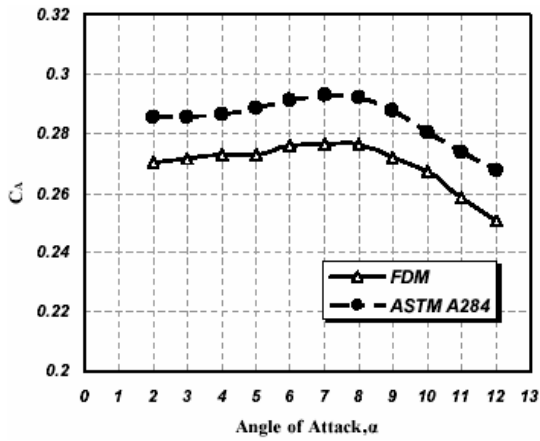

Fig. 7 Comparison of total axial force coefficient at Mach 0.3

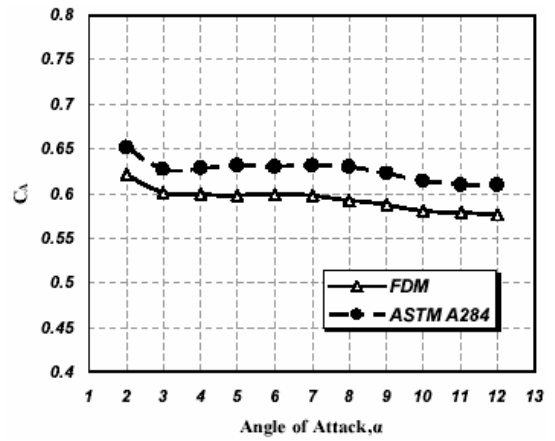

Fig. 10 Comparison of total axial force coefficient at Mach 0.5

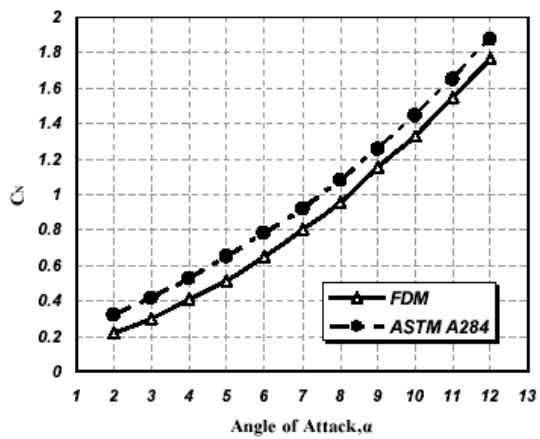

Fig. 8 Comparison of normal force coefficient at Mach 0.5

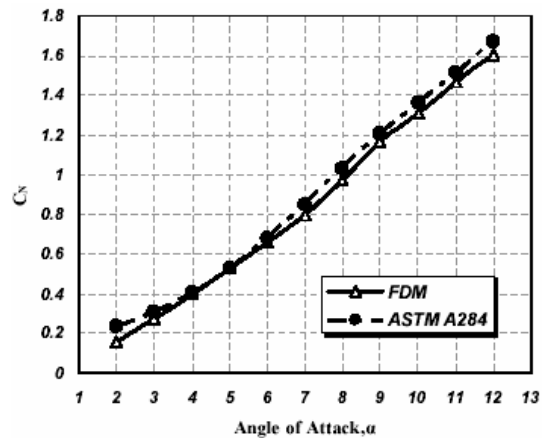

Fig. 11 Comparison of normal force coefficient at Mach 0.75

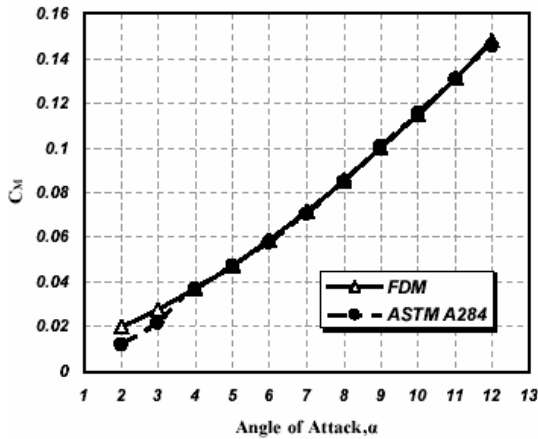

Fig. 12 Comparison of pitching moment coefficient at Mach 0.75

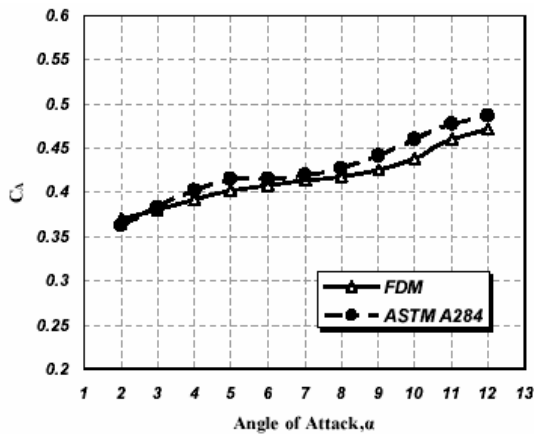

Fig. 13 Comparison of total axial force at Mach 0.75

TABLE V
WIND TUNNEL MODEL TIME AND COST SUMMARY

Model Cost & Time	FDM-PC	Steel
RP Model	\$550	
Balance Adapter	\$100	
Total Cost	\$650	\$1300
Time	1-2 Weeks	1 Month

X. ACCURACY

The data accuracy resulting from the test can be divided into source of error in model dimensions. The dimensions of each model must be compared. The contours of the models used in this test were measured at two wing sections, vehicle stations, tail sections, and the XY and XZ planes [12]. A comparison of model dimensions is shown in Table VI. Two sectional cuts were made on each wing, left and right; two on the body; two on the vertical tail, and one cut in the XY and XZ planes. This shows a representation of the maximum discrepancy in model dimensions relative to the baseline CAD model used to construct all the models at each given station. The standard model tolerance is 0.12 mm.

TABLE VI
MODEL DIMENSIONS COMPARED TO THEORETICAL (MM)

	steel	FDM
Wing L1	0.240	0.251
Wing L2	0.110	0.246
Wing R1	0.106	0.140
Wing R2	0.137	0.220
Body 1	0.170	0.130
Body 2	0.048	0.110
Tail 1	0.080	0.200
Tail 2	0.070	0.150
XY plane	0.030	0.160
XZ plane	0.060	0.240

XI. CONCLUSION

It can be concluded from this study that wind tunnel models constructed using rapid prototyping method and materials can be used in wind tunnel testing for initial baseline aerodynamic database development. The accuracy of the data is lower than that of a metal model due to surface finish and dimensional tolerances, but is quite accurate for this level of testing. The use of RP models will provide a rapid capability in the determination of the aerodynamic characteristics of preliminary designs over a large Mach range. This range covers the transonic regime, a regime in which analytical and empirical capabilities sometimes fall short. Cost savings and model design/fabrication time reductions of over a factor of 2 have been realized for RP techniques as compared to current standard model design/fabrication practices. However, at this time, replacing machined metal models with RP models for detailed parametric aerodynamic and control surface effectiveness studies is not considered practical because of the high configuration fidelity required and the loads that deflected control surfaces must withstand. The current plastic materials of RP models may not provide the structural integrity necessary for survival of thin section parts such as tip fins and control surfaces. At this time, RP method and materials can be used for only preliminary design studies and limited configurations due to the rapid prototyping material properties which allow bending of model components under high loading conditions.

REFERENCES

- [1] Song, Y., Yan, Y., Zhang, R., Xu, R. and Wang, F., "rapid prototyping and rapid tooling technology", Journal of Materials Processing Technology, Vol. 120, no. 3, pp.237-42, 2002.
- [2] Bohn, Jan H., "Integrating Rapid Prototyping into the Engineering Curriculum – A Case Study," Rapid Prototyping Journal, Vol. 3, No.1, pp. 32-37, 1997.
- [3] De Leon, John E, and Gary Winek, "Incorporating Rapid Prototyping Into the Engineering Design Curriculum," Engineering Design Graphics Journal, Vol. 64, No. 1, pp. 18-23, 2000.
- [4] Bocking, C, Jacobson, D.M., Sangha, S.P.S., Dickens, P.M., and Soar, R., "The Production of Large Rapid Prototype Tools Using Layer Manufacturing Technology", Journal of Technology, Vol. 14, No. 2, pp. 110-14, 1997.

- [5] Cho, I., Lee, K., Choi, W., Song, Y. "Development of a new type rapid prototyping system", *International Journal of Machine Tools & Manufacture*, vol. 40, no. 4, pp.1813-29, 2000.
- [6] Thrimurthulu, K., Pandey, P.M., Reddy, N.V. "Part Deposition Orientation in Fused Deposition Modeling", *International Journal of Machine Tools and Manufacture*, vol. 44, pp. 585-594, 2004.
- [7] Steve Upcraft, Richard Fletcher, "The rapid prototyping technologies," *Journal of Assembly Automation*, vol. 23, no. 4, pp. 318–3308, 2003.
- [8] <http://www.matweb.com>
- [9] Jones, Pandey, R.T., "The Oblique Wing craft design for Transonic and Low Supersonic Speeds," *Acta Astronautic*, Vol. 4, per gammon Press, 1999.
- [10] A. Springer, "Evaluating Aerodynamic Characteristics of Wind-Tunnel Models Produced by Rapid Prototyping Methods," *Journal of Spacecraft and Rockets*, vol. 35, no. 6, pp. 755–759, 1998.
- [11] Springer, A.; Cooper, K.; and Roberts, F. "Application of Rapid Prototyping Models to Transonic Wind tunnel Testing. AIAA 97–0988, 35th Aerospace Sciences Meeting. January 1997.
- [12] Springer A, Cooper K, "Comparing the Aerodynamic Characteristics of Wind Tunnel Models Produced by Rapid Prototyping and Conventional Methods," AIAA 97–2222, 15th AIAA Applied Aerodynamics Conference, June 1997.

A. Ahmadi Nadooshan received his MSc degree in Mechanic/Thermo-Fluid from Sharif University of Technology (Tehran, Iran) in 1998. His current research interest includes Fluid mechanic (Computational Fluid Dynamic).

S. Daneshmand received his MSc degree in Mechanic/Manufacturing and Production from IAU Science and Research Branch. His current research interests include Rapid Production Methods and High Precision Tools.

C. Aghanajafi received his PhD in Mechanic/Thermo-Fluid. He is currently Associate Professor at the Department of Mechanical Engineering, K. N. T. University of Technology, Tehran, Iran.