

# Design of Moving Sliding Surfaces in A Variable Structure Plant & Chattering Phenomena

T.C. Manjunath

**Abstract**—This paper deals with the design of a moving sliding surface in a variable structure plant for a second order system. The chattering phenomena is also dealt with during the switching process for an unstable sliding surface condition. The simulation examples considered in this paper shows the effectiveness of the sliding mode control method used for the design of the moving sliding surfaces. A simulink model of the continuous system was also developed in MATLAB-SIMULINK for the design and hence demonstrated. The phase portraits and the state plots shows the demonstration of the powerful control technique which can be applied for second order systems.

**Keywords**—Sliding mode control, VSC, Reaching phase, Sliding phase, Moving surfaces, Chattering, Trajectories.

## I. INTRODUCTION

VARIABLE structure control (VSC) with sliding mode control was first proposed and elaborated in the early 1950's in the Soviet Union by Emelyanov and several co-researchers [6], [7], [8]. In their pioneer works, the plant considered was a linear second-order system modeled in phase variable form. Since then, VSC has developed into a general design method being examined for a wide spectrum of system types including nonlinear systems, multi-input / multi-output systems, discrete-time models, large-scale and infinite-dimensional systems, and stochastic systems.

In addition, the objectives of VSC have been greatly extended from stabilization to other control functions. The most distinguished feature of VSC is its ability to result in very robust control systems; in many cases invariant control systems result. Loosely speaking, the term “invariant” means that the system is completely insensitive to parametric uncertainty and external disturbances. Today, research and development continue to apply VSC to a wide variety of engineering systems. The theory of sliding model control (SMC) is based on the concept of varying the structure of the controller by changing state of the system in order to obtain a desired response [25]. Generally, a switching control action is used to switch between different structures and the system state is forced to move along the chosen manifold, called the switching manifold which determines the closed loop system behavior [26], [27].

Variable Structure Control Systems (VSCS) have been developed in the west after the initial work of Itkis and Utkin in the USSR and have taken many forms. The use of VSCS has been developed in the USA and Europe by workers like Zinober, White, Young, Ryan, Slotine, Spurgeon, Edwards and

Sastry, covering model following, uncertainty and non-linear systems. Variable Structure Control Systems essentially try to keep the dynamic behavior of a system constant by dynamically varying the feedback gains of the system.

A basic VSCS control system is shown in the Fig. 1 below. The compensator blocks C and H contain gains that the VSCS switches dynamically in order to maintain the performance of the closed loop system. The switching is controlled by reference to a performance measure or switching function that is constructed from either the state vector or the output vector of the system. This performance measure is used in a switching strategy to minimize the deviation of the system performance away from the desired performance. The output from the performance measure is zero when the system is performing correctly and the switching strategy is designed to maintain the performance measure at zero at all times.

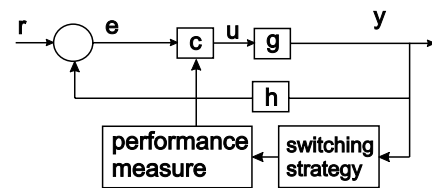

Fig. 1 Stable Resultant Structure.

The paper is organized as follows. Following the brief introduction in section 1, sliding mode design in VSC is dealt with in section 2. Various phases such as the reaching phase and the sliding phase for systems is considered in section 3. Time varying systems is presented in section 4. Section 5 gives the design of stability of systems, whereas section 6 discusses about the chattering phenomenon in sliding mode design. Uniqueness of sliding surfaces is presented in Section 7. The simulation results are presented in section 8. The paper concludes with the conclusion presented in section 9 followed by the references.

## II. SLIDING MODE IN VSC

In Variable Structure systems the system is assumed to be consisting of continuous subsystems known as structures. These structures are changed or switched depending on the state of the system [1]. The gain of a system may be changed or the transfer function of the system may be completely changed in these types of systems. The times (states) at which the structures change contribute to discontinuity surfaces in the phase planes. These surfaces are also called as switching surfaces. If the switching surface satisfies the condition of

having positive attraction then such a surface would become a sliding surface. A simple example of such a variable structure system would be a second order system having system equations

$$\begin{aligned} \dot{x}_1 &= x_2 \\ \dot{x}_2 &= a x_1 + b x_2 + u \end{aligned} \tag{1}$$

where  $x_1, x_2$  are the states of the system and  $a$  and  $b$  are the system parameters. The system has a feedback input given by

$$u = -\Psi x_1 \tag{2}$$

The parameter  $\Psi$  is a variable parameter that takes values  $\alpha$  and  $\beta$  as the structure changes. Suppose the system with input as  $\alpha$  has complex eigen-values with positive real part and the system with input as  $\beta$ , has eigen-values real but one positive and one negative, then the system trajectories in the two structures are both unstable as shown in Fig. 2 The complex eigen-values give an unstable focus whereas the one positive and one negative real eigen-value give a saddle point [2], [3].

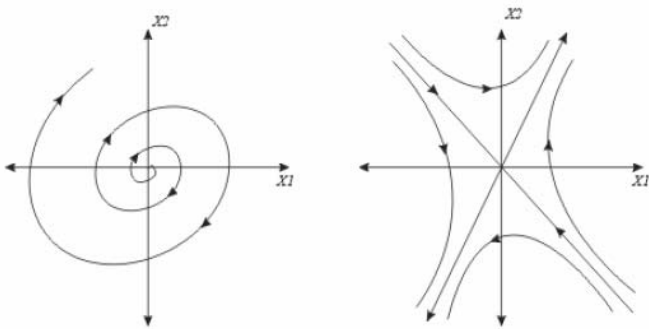

Fig. 2 Two unstable structures.

If we observe carefully we can notice that the two unstable structures have certain regions of stability, like the describing point moves towards the saddle point along the eigenvector corresponding to the negative eigen-value. To have the desired regions of the two structures in the resultant system, two switching surfaces are selected [4].

$$\begin{aligned} x_1 &= 0 \\ s = c x_1 + x_2 &= 0 \end{aligned} \tag{3}$$

Selecting the switching law from these two equations we get

$$\Psi = \begin{cases} \alpha & x_1 s > 0 \\ \beta & x_1 s < 0 \end{cases} \tag{4}$$

The phase portrait of the resultant system is as shown in Fig. 3. As we can see that the switching surface  $x_1 = 0$  has attraction properties only on one side of the surface, no sliding occurs but the switching surface  $s$  has attraction property on both sides of the surface as a result this surface becomes the sliding surface of the system. If we look at the resultant motion on the sliding surface, the describing point slides

towards the equilibrium point and hence the closed loop system is stable.

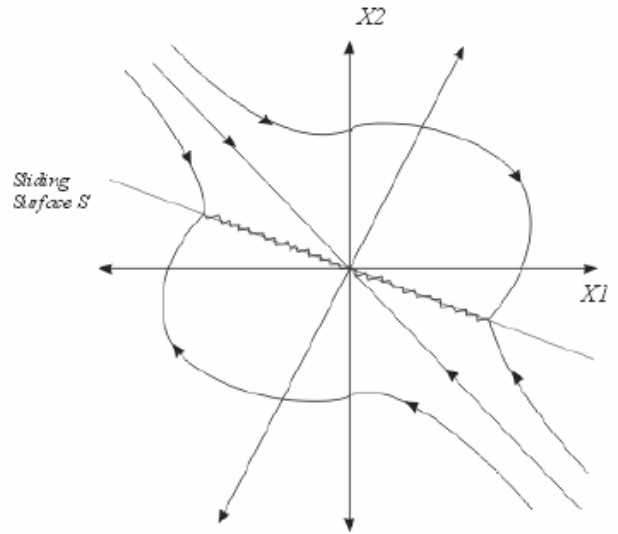

Fig. 3 Stable Resultant Structure.

### III. VARIOUS PHASES OF SLIDING MODE

The sliding mode control can be viewed as a control process consisting of two important phases,

#### 1. The reaching phase :

The reaching phase is the part where the describing point starts from its initial condition and moves towards the sliding surface. In this phase the point follows the system trajectories corresponding to the fixed input system.

#### 2. The sliding phase :

This is the phase in which the describing point moves only on the desired sliding surface. In this phase the describing point does not necessarily follow any system trajectory that was present in the original fixed input system. This is because at the sliding surface the input continuously switches, and the system description is essentially discontinuous.

To find the equation of the system along the sliding surface many methods have been proposed. This is due to the fact that the differential equations have a non-analytic right hand side, which is the relay type discontinuity. Equivalent control method is one of the methods used to solve this problem.

Consider a linear time invariant  $n^{\text{th}}$  order plant with scalar control

$$\dot{x}(t) = A x(t) + B u(t) \tag{5}$$

where matrix  $A$  of size  $n \times n$  defines the system transformation matrix and vector  $b$  the  $n \times 1$  input vector. The sliding surface is defined as

$$s = Cx$$

$$s = \begin{bmatrix} c_1 & c_2 & c_3 & c_4 \end{bmatrix} \begin{bmatrix} x_1 \\ x_2 \\ x_3 \\ x_4 \end{bmatrix} \quad (6)$$

The vector  $C$  consist of coefficients that describe the sliding surface in terms of the state vector  $x$ . The sliding surface defined such a way is called a hyper surface, i.e., it is one dimension lesser than the system order. The surface need not be a plane (or line in case of second order system) always, the surface can be of any shape.

In that case the vector  $C$  is the gradient of the sliding surface lets say  $G$ . If the sliding surface is a plane then the gradient of the matrix is the matrix itself. The value  $s$  specifies the distance of the point from the sliding surface, hence  $s = 0$  implies the point is on the sliding surface. The scalar input

$$u = -\sum_{i=1}^n \Psi_i x_i \quad (7)$$

Differentiating Eqn. (6) and the substituting Eqn. (5), we get

$$\dot{s} = C \dot{x}$$

$$\dot{s} = CAx + Cbu$$

on the sliding surface  $s = 0$  and for the sliding to exist we must have  $\dot{s} = 0$ . This gives us the equivalent input. Assuming that  $Cb$  is invertible we get

$$u_{eq} = -(Cb)^{-1} CAx \quad (8)$$

Substituting the equivalent input into the system Eqn. (5), we get an autonomous system that describes the motion of the describing point on the sliding surface.

$$\dot{x} = \{I - b(Cb)^{-1}C\}Ax \quad (9)$$

Once, on the sliding surface the system can be thought of as a  $(n - 1)$ dimensional system or a system on its invariant set. An invariant set is a set such that once the system state enters the subset it cannot leave the subset. Adding another sliding surface i.e., equivalent to adding another relay input, the system dimension may be further reduced so as to achieve a sliding not only on the two individual surfaces but also on the intersection of the sliding surfaces as shown in Fig. 4.

In such a case, the describing point would first move along its natural system trajectories till it first intersects a single sliding surface, it will then slide along the surface following some trajectory of the system till it intersects with the second sliding surface and the slides along the intersection of the sliding surfaces till it reaches the system equilibrium point.

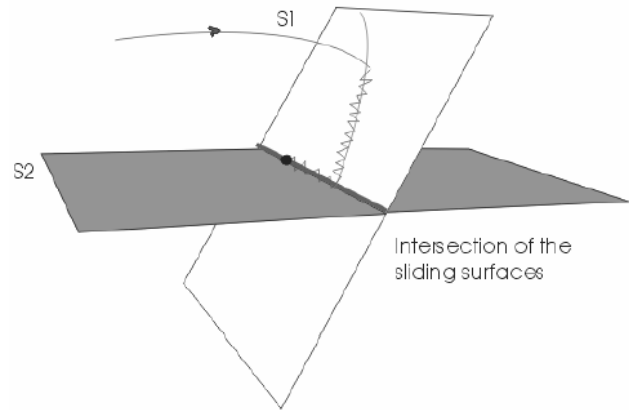

Fig. 4 Sliding surface in 3 D plane.

In the case of two or more sliding surfaces, the vector  $C$  corresponding to the coefficients describing the sliding surface will become a matrix. Thus an  $n$  order system having  $(n - 1)$  sliding surfaces will have the matrix  $C$  of size  $\{(n - 1) \times n\}$  and the sliding constraints look like given in the Eqn. (10).

We assumed that  $\dot{s} = 0$ , as a result the input is called the equivalent control input and the corresponding surface is called the ideal sliding surface. Practically  $\dot{s} \neq 0$ , in such a case the input is called the actual input and the sliding surface is called the real sliding surface.

$$\begin{bmatrix} s_1 \\ s_2 \\ s_3 \\ \vdots \\ \vdots \\ s_{n-1} \end{bmatrix} = \begin{bmatrix} c^1_1 & c^1_2 & c^1_3 & \dots & c^1_n \\ c^2_1 & c^2_2 & c^2_3 & \dots & c^2_n \\ \vdots & \vdots & \vdots & \ddots & \vdots \\ c^{n-1}_1 & c^{n-1}_2 & c^{n-1}_3 & \dots & c^{n-1}_n \end{bmatrix} \begin{bmatrix} x_1 \\ x_2 \\ x_3 \\ \vdots \\ \vdots \\ x_n \end{bmatrix} \quad (10)$$

#### IV. TIME VARYING SYSTEMS

In the case of a time varying system, we assume the system transformation matrix and the input matrix to have time varying coefficients. The system would then be represented as

$$\dot{x} = A(t)x + b(t)u \quad (11)$$

In such a system, the input parameters cannot be selected as time varying, i.e., one has to select a constant valued  $\alpha$  and  $\beta$ . The method used to determine input bounds for a sliding condition over a local area is by finding the bounds on the parameters  $a(t)$  and  $b(t)$ . The constraints that one obtains so are :

Case for  $s > 0$  :

$$Ca_1x_1 + Ca_2x_2 + Ca_3x_3 < Cb\alpha x_1 \quad (12)$$

where  $a_i = \sup(a_i(t))$  and  $b = \inf(b(t))$  (13)

Case for  $s < 0$  :

$$C a_1 x_1 + C a_2 x_2 + C a_3 x_3 > C b \beta x_1 \quad (14)$$

$$\text{where } a_i = \inf(a_i(t)) \text{ and } b = \sup(b(t)) \quad (15)$$

However, we can see that when the variation of  $a(t)$  and  $b(t)$  is very large the bounds on the input are at the extreme values to take care of the worst conditions that may occur in the system.

As a result, this approach is not very efficient and hence results in higher input bounds.

### V. STABILITY OF SYSTEMS

Satisfying only the reaching condition does not mean that the describing point will slide along the surface. Similarly, satisfying the sliding condition does not imply that the system will be stable.

This happens when the Fillipov's resultant of the force vectors acting on the two sides of the sliding surface do not point in the direction of the equilibrium point, but in the opposite direction. This may cause the describing point to exponentially escape to infinity along the sliding surface as shown in the Fig. 5.

To check the stability of the sliding surface, one can use the Lyapunov second method of determining stability. It states that if the projection of the system trajectories on the sliding surfaces are stable then the system is stable. The theorem can thus be formulated as:

**Theorem :** *If there exist a function  $v(s, x, t)$  where  $s$  is the distance from the sliding surface and  $x$  the states variables, which is positive definite i.e. it satisfies the following conditions.*

1.  $v(s, x, t) > 0$  with  $s \neq 0$  and arbitrary  $x$  and  $t$ .
2.  $v(s, x, t)$  is continuous and differentiable.
3.  $v(0, x, t) = 0$  for all  $x$  and  $t$ .

*and its derivative  $\dot{v}(s, x, t)$  is negative everywhere except the discontinuity surface, then the system is stable.*

There is no specific method to find the Lyapunov function candidate however V.I. Utkin [9] has discussed the method of using quadratic forms to find the sliding domain.

### VI. CHATTERING

The chattering phenomenon primarily occurs due to the existence of non-ideal relays, having hysteresis effects and finite time delays in switching of the output.

Thus, at all practical switching surfaces there exists a finite amount of chatter. The phenomenon can be best explained with a diagram as shown below in Fig. 6.

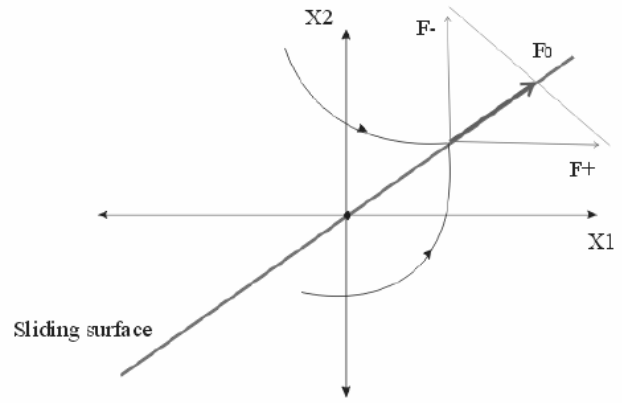

Fig. 5 Lyapunov method of determining stability.

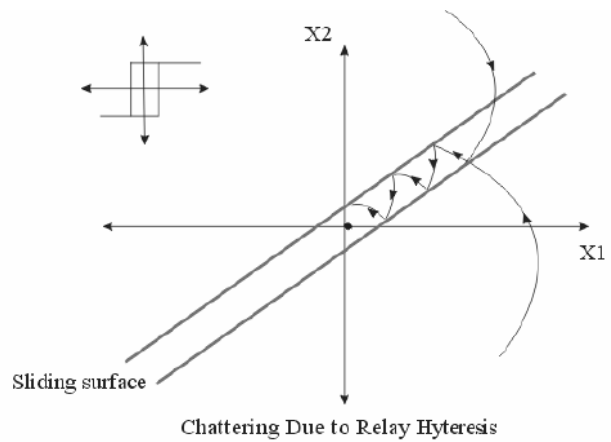

Fig. 6 Chattering phenomenon.

### VII. UNIQUENESS OF SLIDING SURFACES

Systems discussed so far are linear systems. In case of linear systems, the real sliding surfaces in the presence of non-idealities can be shown to uniquely approach the ideal sliding surfaces determined by the equivalent control method, as the non-idealities are taken to tend to zero. But there are cases where the system is nonlinear with respect to input, and the input is either scalar or vector. The validity of equivalent control method for determining the sliding equation for such cases has been discussed [28].

### VIII. SIMULATION

Two case studies of CT systems were considered. One is the moving sliding surface in a variable structure plant for a process control system modeled as a second order plant as shown in Fig. 7 and the other is the unstable sliding surface with chattering phenomenon again for a second order simple pendulum system modeled as a undamped system as shown in Fig. 10. Both the simulink models are developed for second order continuous time systems [28].

**Simulation 1 :** Moving sliding surface in variable structure plant.

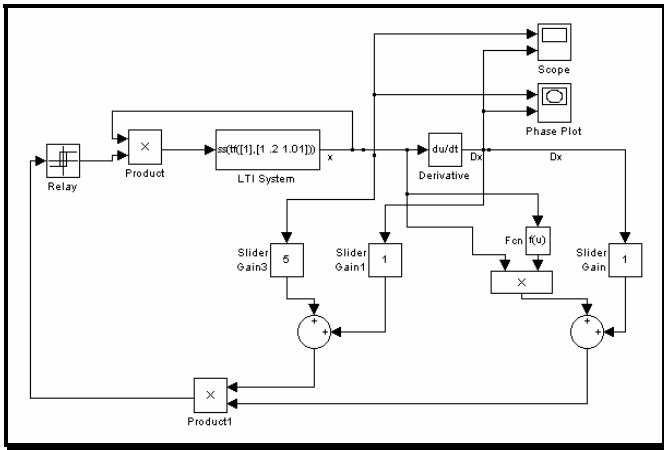

Fig. 7 Moving sliding surface for a process control system.

**Description:** The second order system has a transfer function of  $\frac{1}{s^2 + 0.2s + 1.01}$ .

The switching surfaces selected were  $\dot{x} + 5x = 0$  and a moving sliding surface that is a function of error in  $x$ .

The sliding surface is hence not fixed, but changes slope in a region where stable sliding properties are satisfied.

The initial conditions were  $\dot{x} = 90$  and  $x = -70$ . The results of simulation are as follows.

The sliding mode controller when applied to the plant gave the following results shown in Figs. 8 and 9 respectively.

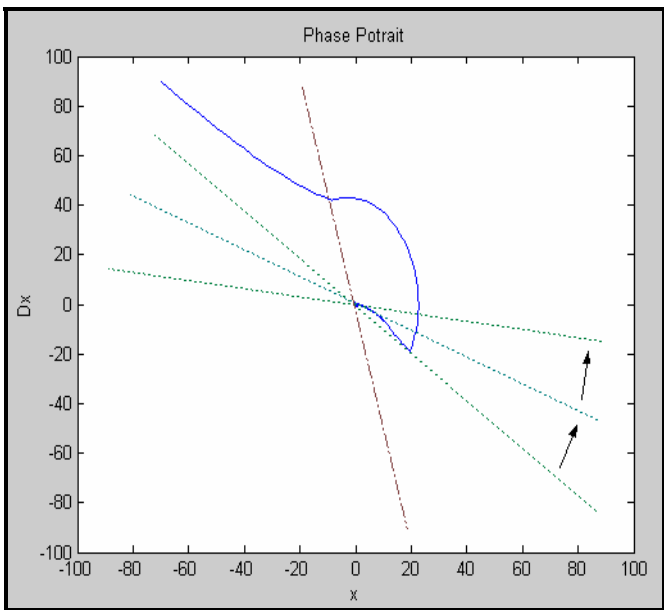

Fig. 8 Phase portrait of the model in Fig. 7.

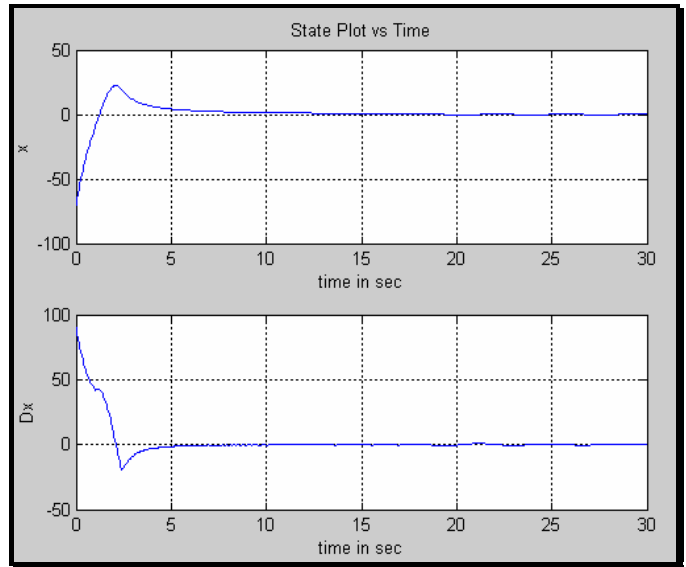

Fig. 9 Plot of states as a function of time.

**Simulation 2 :** Unstable sliding surface and chattering phenomenon.

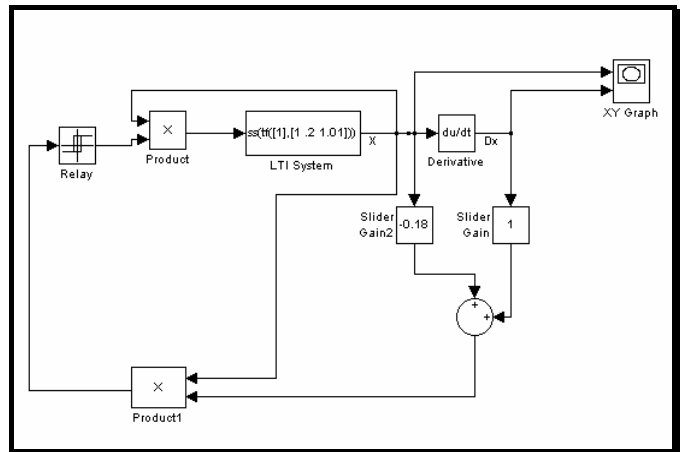

Fig. 10 Unstable sliding surface model.

**Description:** The second order system has a transfer function of  $\frac{1}{s^2 + 0.2s + 1.01}$ . The switching surfaces selected were  $x = 0$  and  $\dot{x} - 0.18x = 0$ . The sliding surface is  $\dot{x} - 0.18x = 0$  but the system is unstable. The initial conditions were  $\dot{x} = 90$  and  $x = -70$ . The chattering phenomenon is enhanced by use of relay with large hysteresis. The results of simulation are as shown in Figs. 11 and 12 respectively.

IX. APPLICATIONS OF THE DESIGNED CONTROL TECHNIQUE

The application of sliding mode is vast and can be applied to both linear and non-linear systems. However for linear systems the technique is not used since there are other well defined

methods for arbitrary pole placement. However the concept of such control for non-linear systems do not exist as yet. Sliding mode control provides in most cases a simple and easier method of controller design. It also can be used to design optimal controllers. Some of the applications where sliding mode has been used are robot control, aircraft control, space control, engine control, nuclear control, etc.,.

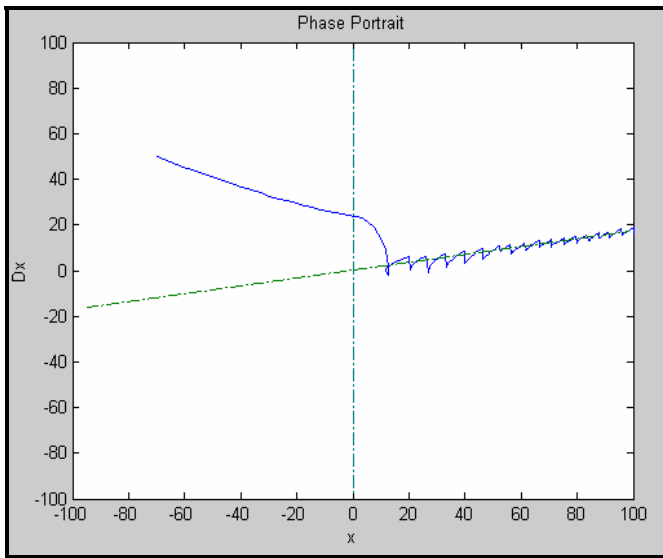

Fig. 11 Phase portrait for the model shown in Fig. 10.

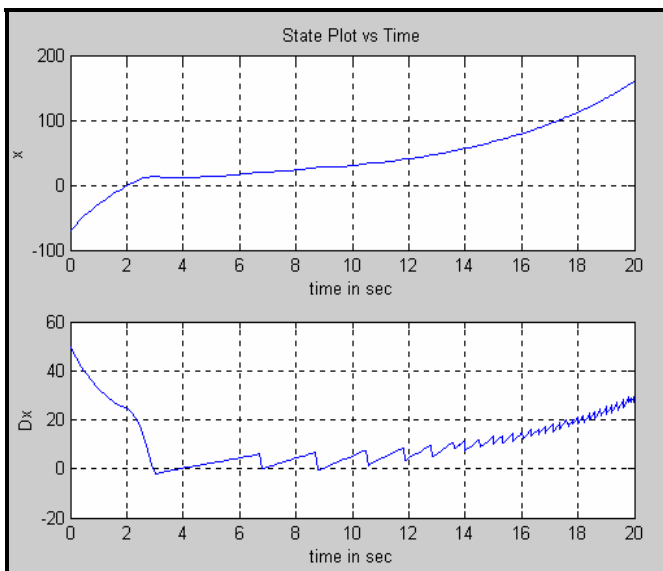

Fig. 12 Plot of states as a function of time.

#### REFERENCES

- [1] Andronov, A. A., Vitt, A. A., Khaikin, S.E. Teoriya kolebaniy, *Theory of Oscillation*, Fizmatgiz, Moscow, 1959.
- [2] Bernshtein, S. I., Theory of Vibrational Controllers of Electrical Machinery, *Proceedings of the Second All Union Conference on Control Theory*, Vol. 1, Izd-vo AN SSSR, Moscow, 1955.
- [3] Kulebakin, V. S., On the Theory of Automatic Vibrational Controllers for Electrical Machinery, *Teoreticheskaya i eksperimental'naya elektrotekhnika*, No. 4, 1932.
- [4] Gamkrelidze, R. V., On Optimal Sliding Modes, *DAN SSSR*, Vol. 143, No. 6, 1962.
- [5] Krotov, V. F., Methods to Solve Variational Problems by Using Sufficient Conditions of the Absolute Minimum 1, *Avtomatika itelemekhanika*, Vol. 23, No. 12, 1962.
- [6] S. V. Emelyanov, Variable Structure Control Systems. Moscow: Nauka, (in Russian), 1967.
- [7] Y. Itkis, Control Systems Of Variable Structures, New York: Wiley, 1976.
- [8] ---, Sliding Modes and their Applications in Variable structure Systems. Moscow: Nauka (in Russian) (also Moscow: Mir, 1978, in English).
- [9] V. I. Utkin, Sliding Modes and their Applications in Variable structure Systems. Moscow: Mir, 1978, in English.
- [10] K. K. D. Young, Asymptotic Stability of Model reference System with variable structure control, *IEEE trans. Automat. Contr.*, Vol. AC-22, No. 4, pp. 279-281, 1977.
- [11] ---, Controller Design for a Manipulator Using Theory of Variable Structure Systems, *IEEE trans. Syst. Man Cybern.*, Vol. SMC-8, No. 2, pp. 101-109, 1978.
- [12] R. G. Morgan, and U. Ozguner, A Decentralized Variable Structure Control algorithm for Robotic Manipulators, *IEEE J. Robotics and Automation*, Vol. 1, No. 1, pp. 57-65, 1985.
- [13] J. J. E. Slotine and S. S. Shastry, Tracking control of Nonlinear Systems using Sliding Surfaces with Application to Robot Manipulators, *Int. J. Contr.*, Vol. 38, No. 2, pp. 465-492, 1983.
- [14] Balestrino and A. Landi, Intelligent variable Structure Control in Electrical Drives, in 1990 *IEEE Int. Workshop on Intelligent Motion Control*, 1990.
- [15] D. Borojevic, H. Naitoh, and F. C. Lee, 1986, Soft Variable structure Based Adaptive PI Control for D.C. Motor position Control, *Proc. IEEE Industry Applications Society annual meeting*, pp. 283-288.
- [16] Feller, P. and U. Benz, Sliding Mode Position Control of a DC Motor, *Proc. 10th IFAC World Congress*, Vol. 3, pp. 333-338, 1987.
- [17] Hyeung-sik Choi, Yong-heon Park, Global Sliding Mode Control, Improved Design for Brushless DC Motor, *IEEE Control system magazine*, Vol. 1, pp. 27-35, 2001.
- [18] B. A. White, R. J. Patton, S. Mudge, and P. P. Aslin, Reduced Order Variable Structure Control of the Lateral motion of an Aircraft, *Proc. 25th Conf. Decision and Contr.*, Athens, Greece, 1986, pp. 322- 327.
- [19] S. N. Singh, Asymptotically decoupled Discontinuous Control of Systems and Nonlinear Aircraft Maneuver, *IEEE Trans. Aerosp. Electron. Syst.* Vol. AES-25, No. 3, pp. 380-391, 1989.
- [20] J. K. Hedric and S. Gopalswamy, Nonlinear Flight Control Design via Sliding Methods, *J. Guid. Contr. Dynamics*, Vol. 13, No.5, pp. 850-858, 1990.
- [21] T. A. W. Dwyer, III, and H. Sira-Ramirez, Variable Structure Control of Spacecraft Attitude Maneuvers, *J. Guidance*, Vol. 11, No 3, pp. 62- 270, 1980.
- [22] H. Sira-Ramirez and T.A. W. Dwyer, III, Variable Structure Controller Design for Spacecraft Rotation Damping, *IEEE Trans. Automat. Contr.*, Vol. AC-32, No. 5, pp. 435-438, 1987.
- [23] S. N. Singh and A. Iyer, Nonlinear Decoupling Sliding Mode Control and Attitude Control of Spacecraft, *IEEE Trans. Aerosp. Electron. Syst.* Vol. AES-25, No 5, pp. 621-633, 1989.
- [24] C. Lagoa and H. Che, Decentralized Optimal Traffic Engineering in the Internet *Electronic paper, PDF file*.
- [25] Utkin, V. I., Variable structure systems with sliding modes, *IEEE Trans. Automat. Contr.*, Vol. AC-22, Pg. 212-222, 1977.
- [26] Hung, J. Y., Gao W., Hung J.C., Variable structure control : A survey, *IEEE Trans. Ind. Electron.*, Vol. 40 (1), Pg. 2-21, 1993.
- [27] Young, K. D., Utkin, V. I., Ozguner, U., A control engineer's guide to sliding mode control, *IEEE Trans. Contr. Syst.*, Vol. 7 (3), Pg. 328-342, 1999.
- [28] T.C.Manjunath, Muddu. M., Arounasalome, G. Dattatreya Reddy, "Design of stable and optimal sliding surfaces in second order systems using sliding mode control", *Proceedings of the 1<sup>st</sup> National Conference on Process Identification, Control & Diagnosis (NCPICD-2005), Madras Institute of Technology, Chennai-44, Tamil Nadu, India*, Paper No. 4, Session 2, pp. 77 - 87, 16<sup>th</sup> Dec-17<sup>th</sup> Dec. 2005.



**T. C. Manjunath**, born in Bangalore, Karnataka, India on Feb. 6, 1967 received the B.E. Degree in Electrical Engineering from the University of Bangalore in 1989 in First Class and M.E. in Electrical Engineering with specialization in Automation, Control and Robotics from the University of Gujarat in 1995 in First Class with Distinction and Ph.D. from the Interdisciplinary Programme in

Systems and Control Engineering Department of Indian Institute of Technology Bombay in the year 2007, respectively. He has got a teaching experience of 17 long years in various engineering colleges all over the country (Karnataka, Tamil Nadu, Gujarat, Maharashtra) and is currently working as Professor and Head of the Department of Electronics and Communication Engineering in East West Institute of Technology in Bangalore, Karnataka, India. He also worked as a Research Engineer in the Systems and Control Engineering (IIT Bombay, India) for nearly a year and worked on control of space launch vehicles using FOS feedback technique. He has published 90 papers in the various national, international journals and conferences and published two textbooks on Robotics, one of which has gone upto the fourth edition, titled, 'Fast Track to Robotics' and the other, which has gone upto the fifth edition, titled, 'Fundamentals of Robotics' in 2 volumes, Vol.-1 and Vol.-2 along with a CD which contains about 150 C / C++ programs for performing various simulations on robotics. He also published a research monograph in the International level from the Springer-Verlag publishers based on his Ph.D. thesis topic titled, "Modeling, Control and Implementation of Smart Structures", Vol. 350, LNCIS, costing 79.95 Euros. He was a student member of IEEE for 6 years, SPIE student member and IOP student member for 4 years, life member of ISSS (India), life member of the ISTE (India), life member of ISOI (India), life member of SSI (India). He has visited Singapore, Russia, United States of America and Australia for the presentation of his research papers in various international conferences. His biography was published in 23<sup>rd</sup> edition of Marquis's Who's Who in the World in 2006 issue. He has also guided more than 2 dozen robotic projects. Many of his guided projects, interviews have appeared in various national newspapers and magazines. He has also presented a number of guest lectures and various seminars and participated in more than a dozen CEP / DEP courses, seminars, workshops, symposiums in the various parts of the country in different institutions and also conducted a few courses. His Ph.D. research work was based on the mathematical modeling, control and implementation of smart structures and its applications. His current research interests are in the area of Robotics, Smart Structures, Control systems, Network theory, Mechatronics, Process Control and Instrumentation, Electromagnetic fields and waves, MATLAB, Signals and systems (CT and DT), Industrial automation, Artificial intelligence, Digital signal processing, Periodic output feedback control, Fast output feedback control, Sliding mode control of SISO and multivariable systems and many of the control related subjects and its allied labs and their various applications.