

A Low Voltage High Linearity CMOS Gilbert Cell Using Charge Injection Method

Raheleh Hedayati, Sanaz Haddadian, and Hooman Nabovati

Abstract—A 2.4GHz (RF) down conversion Gilbert Cell mixer, implemented in a 0.18- μm CMOS technology with a 1.8V supply, is presented. Current bleeding (charge injection) technique has been used to increase the conversion gain and the linearity of the mixer. The proposed mixer provides 10.75 dB conversion gain (G_C) with 14.3mw total power consumption. The IIP3 and 1-dB compression point of the mixer are 8dbm and -4.6dbm respectively, at 300 MHz IF frequencies. Comparing the current design against the conventional mixer design, demonstrates better performance in the conversion gain, linearity, noise figure and port-to-port isolation.

Keywords—Mixer, Gilbert Cell, Charge Injection, RFIC, CMOS Technology.

I. INTRODUCTION

MIXERS are crucial parts of any typical front end circuit, as an example of such an application is shown in Fig. 1 [1].

In the RF transceivers, mixer, which is a nonlinear circuit, is used to perform an important frequency translation from the Radio Frequency (RF) to an Intermediate Frequency (IF) called “down-convert” for the receivers, or from IF to RF called “up-convert” for the transmitters.

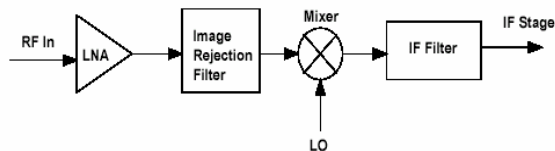

Fig. 1 Down Converter Mixer as a Multiplier in Receivers

Conversion process in time domain is performed by multiplying the RF signal by a signal named Local (LO). Nonlinearity effect of the mixer is necessary for this frequency translation in order to produce sum and difference frequencies.

Nowadays, with the development of the wireless communication technology devices, demand for the wireless service has been constantly increasing. Therefore, 2.4GHz is the frequency band which is set free for the industrial,

S. Haddadian and R. Hedayati are with Sadjad Institute of Higher Education, Mashhad, Iran (phone: +98-915-5077423; e-mail: s.haddadian@iee.org).

H. Nabovati, Department of Electrical Engineering, Sadjad Institute of Higher Education, Mashhad, Iran (e-mail: nabovati@sadjad.ac.ir).

scientific and medical applications. Due to the importance of these applications, in the present study the RF signal is selected to be in this frequency. Setting the ω_{LO} (which is the frequency of local oscillator signal) equal to 2.1 GHz, $\omega_{IF} = \omega_{rf} - \omega_{lo}$ would be 300MHz.

The most commonly used active mixer is double balance architecture, which is also known as the Gilbert Cell mixer which has some improvements over other architectures such as single balanced mixers.

This paper presents an improved architecture of the Gilbert Cell with cascode and current steering techniques to increase the linearity, conversion gain and port-to-port isolation. Fig. 2 illustrates the circuit of proposed mixer.

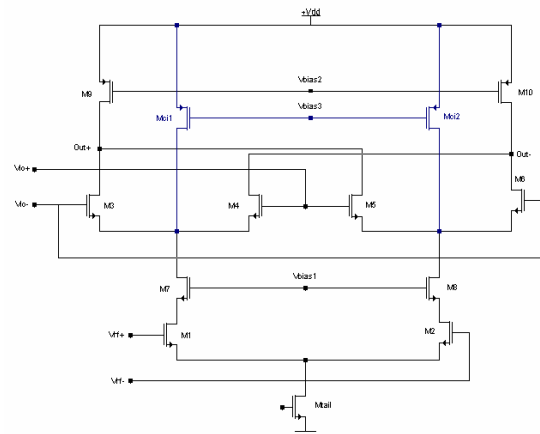

Fig. 2 Circuit of the proposed mixer using cascode and current steering techniques

II. QUALITATIVE DESCRIPTION OF THE PROPOSED MIXER

The proposed mixer circuit consists of three SCPs (Source Coupled Pairs) which form a typical Gilbert Cell mixer architecture. The bottom SCP (M_{1-2}) is used as a V-I converter and the other two SCPs (M_{3-6}) are used to do the switching operation. The V-I converter generates two current inputs from the V_{rf} input signal to the tail nodes of the switches, which are also 180° out of phase.

The switching quad consisting of two parallel connected NMOS pairs are controlled by the local signal. V_{lo} is a square wave which is assumed to be large enough to switch transistors M_{3-6} totally on when it is high and totally off when it is low. In summary, output currents have swapped polarity

synchronization with the controlling V_{lo} and mixing has occurred [2].

Cascode devices (M_{7-8}) are inserted to provide higher isolation between the LO and RF ports.

Three current sources are used in this circuit. The bottom current source (M_{tail}) provides bias current and the top two current sources (M_{ci1} and M_{ci2}) are used to implement the charge injection or the current bleeding technique to improve the performance of the mixer.

The third-order intercept point and the conversion gain of the mixer are proportional to the square root of the driver stage bias current, as follows [2]:

$$G_c = \frac{2}{\pi} g_m R_L = \frac{2}{\pi} R_L \left(\mu_n C_{ox} \frac{W_1}{L_1} I_{tail} \right)^{\frac{1}{2}} \quad (1)$$

$$IIP3 \propto A_{IP3} = \left(\frac{32}{3} \frac{I_{tail}}{\mu_n C_{ox} W_1 / L_1} \right)^{\frac{1}{2}} \quad (2)$$

As a result, the charge injection technique causes higher conversion gain and linearity due to the higher bias current without increasing the switching transistors current and reduction of r_{ds} . Furthermore, with bleeding, either the switching transistors could be operated at lower gate-source voltage or the smaller size transistors could be used.

The transistors M_9 and M_{10} act as loads to increase the voltage conversion gain. In order to achieve output impedance matching, two source-follower transistors are added, which are composed of M_{18-19} and M_{20-21} ; in other word, a buffer circuit is added to the output of mixer.

III. GILBERT CELL DESIGN

As the saturation region offers higher gain and makes the current less susceptible to the changing voltage across the transistors, almost all the transistors are designed to operate in this region [3].

The gain stage transistors should be biased such that they have enough head room to swing without leaving the saturation region; therefore the over drive voltage ($V_{gs}-V_t$) should be assumed around 200mv to 400mv.

The local voltage level should be large enough to make the conversion gain insensitive to the LO amplitude. But if A_{lo} becomes too large, it reduces the switching speed and increases the LO feedthrough. Thus for complete switching, A_{lo} should be between 100mv to 400mv.

If two switching pair transistors conduct at the same time, noise increases. Therefore the overdrive voltage for switching pairs should be as close to zero as possible. Fig. 3 illustrates the proper local switching [3].

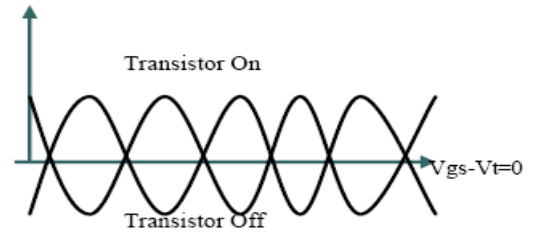

Fig. 3 Illustration of proper LO switching [3]

To choose the appropriate architecture for any mixer, the system's requirements are of the first priority.

In the present study, the required mixer design specifications are as follows:

The proposed mixer was designed based on the following equations [1], [2].

TABLE I
DESIGN TARGETS OF THE MIXER

Parameter	Value
RF Frequency (GHz)	2.4
Conversion Gain (dB)	>12
IIP3 (dbm)	>-5
1-dB Compression point (dbm)	>-8
Noise Figure (dB)	<24
LO-RF Isolation (dB)	>70
RF-LO Isolation (dB)	>70
LO-IF Isolation (dB)	>40
RF-IF Isolation (dB)	>40
Power Consumption (mw)	<20

$$I_{DS} = \frac{1}{2} \mu_n C_{ox} \frac{W}{L} (V_{GS} - V_t)^2 \quad (3)$$

$$G_c = \frac{2}{\pi} g_{m_{1,2}} R_L \quad (4)$$

Assuming that R_L is the input impedance of the IF filter (300Ω -500 Ω) and G_c is about 14dB, g_m can be calculated using the equation (3).

In calculating the aspect ratio of transistors, it has been assumed that:

$$\begin{cases} V_t = 0.5v - 0.8v \\ \mu_n C_{ox} = 3\mu_p C_{ox} = 240 \frac{\mu A}{v} \\ I_{tail} = 8mA \end{cases} \quad (5)$$

It should be mentioned that this value for the I_{tail} is the summation of the currents of both the bleeding transistors (2mA) and the switching pair transistors (6mA).

Assuming over drive voltage for each transistor and their determined currents, the aspect ratios can be simply calculated using (3) and (4); but it should be noticed that working in short channels have the effect that applying a simple voltage

may cause them to work in the velocity saturation conditions and the quadratic relation between I_{ds} and V_{gs} would no longer be as accurate as it is expected.

In calculating the aspect ratio it should be noted that the effective voltage should be in a range that changing different corners and temperature - which widely introduces changes in currents - wouldn't cause the transistors to enter the linear region.

Considering these facts, the bias voltages and the aspect ratios of the transistors are summarized in Table II.

TABLE II
ASPECT RATIOS AND BIAS VOLTAGES OF THE DESIGNED MIXER

Component	W(μm)
M ₁₋₂	130
M ₃₋₆	435
M ₇₋₈	130
M ₉₋₁₀	144
M _{tail}	160
M _{ci1-2}	97
M ₁₈₋₂₀	5.8
M ₁₉₋₂₁	10

Bias1	Bias2	Bias3	G _{tail}	V _{lo}	V _{rf}
1.8v	0.8v	1.2v	0.8v	1.8v	1.4v

IV. MIXER SIMULATION RESULTS

The performance of the mixer was analyzed using the Hspice2007 software. Table III shows the values obtained from the simulation results, which are in good agreement with the theoretical values.

TABLE III
ASPECT RATIOS AND BIAS VOLTAGES OBTAINED FROM THE SIMULATION

Component	W(μm)
M ₁₋₂	131
M ₃₋₆	435
M ₇₋₈	92.4
M ₉₋₁₀	144
M _{tail}	255
M _{ci1-2}	96.6
M ₁₈₋₂₀	5.85
M ₁₉₋₂₁	10

Bias1	Bias2	Bias3	G _{tail}	V _{lo}	V _{rf}
1.7v	0.85v	1v	0.72v	1.8v	1.3v

A. Conversion Gain

Fig. 4(a) shows the output signal at the IF port, and Fig. 4 (b) illustrates the output signal after using the IF filter at 300MHz.

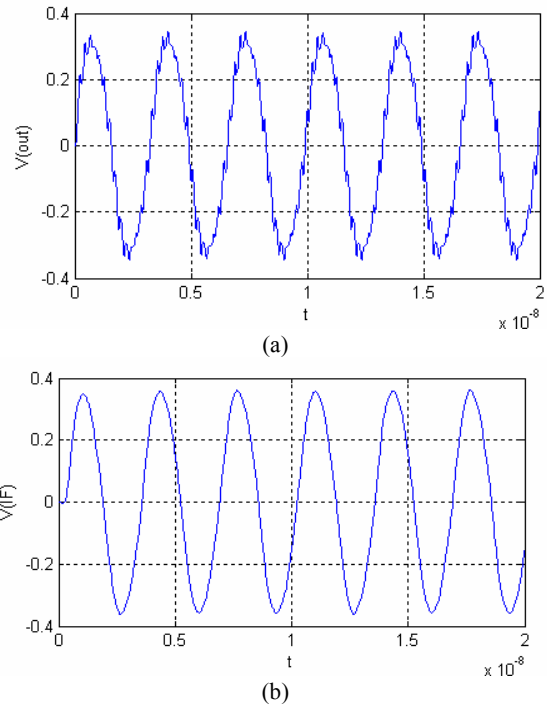

Fig. 4 Output waveform (a) without IF filter (b) with the IF Filter

Since the conversion gain of the mixer is defined as the ratio of the output signal at ω_{if} (345mv) to the amplitude of the RF signal (100mv), G_c is calculated equal to 10.75dB.

B. Port to Port Isolation

Isolation represents the amount of “Leakage” or “Feed through” between the mixer ports [5].

The proposed design for the mixer provides a high degree of LO to IF isolation and is facilitating the filtering requirements at the output.

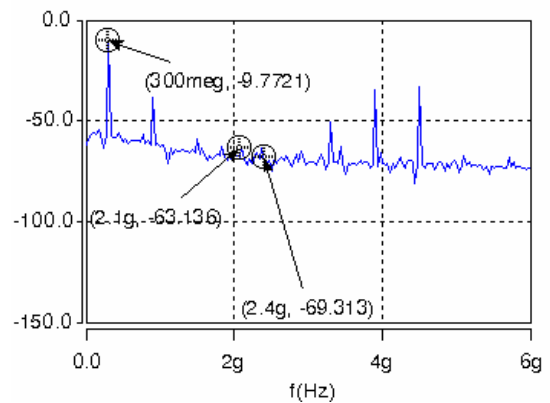

Fig. 5 Simulation Result for Output Frequency Spectrum with $\omega_{rf} = 2.4\text{GHz}$ and $\omega_{lo} = 2.1\text{GHz}$

Fig. 5 illustrates the output frequency spectrum of the mixer. LO-IF and RF-IF isolations are calculated considering the spectrum and equation below:

$$ISO_{LO-IF} = \frac{M_{LoatIF}}{M_{LoatLo}} \quad (6)$$

The M_{LoatIF} and M_{LoatLo} are the magnitude of the LO frequency component at the IF port and the magnitude of the LO signal, respectively.

It is also important to have isolation between the LO and RF ports. Since the LO signal is quite large, a significant amount of it may leak to the mixer's input and then leak back to the antenna through the reverse isolation of the LNA. This local signal at the antenna will radiate out and can interfere with other nearby receivers [4]. In the proposed mixer design, using cascade architecture provides higher isolation between the LO and RF ports. The values of the port-to-port isolation are presented in Table IV.

C. 1-dB Compression Point

Conversion compression relates to the RF input power level above which the curve of the IF output power versus the RF input power deviates from linearity. Above this level, additional increases in the RF input level do not result in proportional increases in the output level [5].

1-dB compression point is the input power level at which the output level reduction is 1dB below the linear characteristic. This parameter is one measure to the mixer's linearity which is shown in Fig. 6. and calculated -4.65dbm.

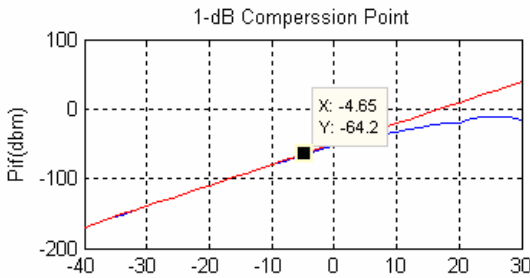

Fig. 6 Simulation result for calculating 1-dB compression Point (1-dB CP= -4.65 dbm)

D. Third Order Intercept Point

Intermodulation appears when the input contains more than one tone.

The two-tone intermodulation test is a relevant way to evaluate IIP3 which is also used to characterize the mixer's linearity.

To investigate the intermodulation properties of the mixer, a two tone intermodulation measurement system is used with the frequency offset of 10MHz. The measured IIP3 is 8dbm for RF two-tone of 2.4GHz and 2.41GHz which is shown in Fig. 7.

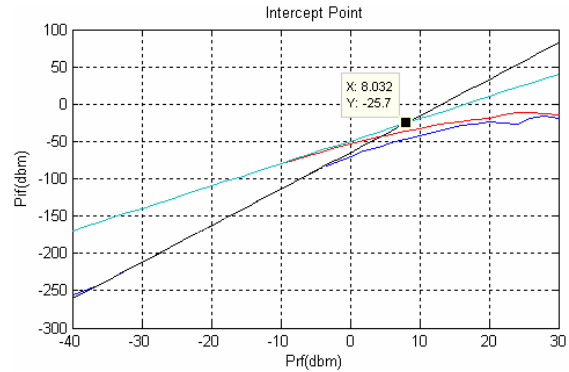

Fig. 7 Simulation Results for Third Order Intercept Point using Two-Tone Approach. Simulated result for IIP3 is 8dbm

For the proposed mixer and the bias circuit which provides the bias voltages, the total DC power consumption is 14.3mw. Table IV summarizes the simulation results.

TABLE IV
SIMULATION RESULTS

Parameter	Value
Conversion Gain(dB)	10.75
IIP3 (dbm)	8.032
1-dB Compression Point (dbm)	-4.65
RF-LO Isolation (dB)	74
LO-RF Isolation (dB)	93
LO-IF Isolation (dB)	52.7
RF-IF Isolation (dB)	49.3
Noise Figure (dB)	16
Power Consumption (mv)	14.3

V. CONCLUSION

Due to the importance of the mixers in the receivers, in this paper, a low voltage and low power fully integrated double-balanced Gilbert cell mixer was designed and simulated using a 0.18-μm CMOS process to achieve specific aspects (pre-specified working conditions).

Charge injection method was used to increase the linearity and conversion gain of the mixer. This topology allows the designer to easily adjust the bias current of the input transistors while maintaining the bias currents in other parts of the circuit. This technique also reduces the Noise Figure.

The second technique which was used to increase the RF and LO isolation is the cascade devices method which caused a higher port to port isolation.

As the active loads are also used to increase the conversion gain of the mixer; in order to have the output impedance matched, two source follower circuits were added to the designed system.

As the simulation results illustrated the total system performance and accuracy, all these techniques caused a better performance for the Gilbert Cell mixer in terms of the linearity, conversion gain, port to port isolation, noise figure and power consumption.

REFERENCES

- [1] V. Chandra, "A 2.5V High Linearity CMOS Mixer for 1.9GHz Applications", Carnegie Mellon University, 2002.
- [2] B. Leung, "VLSI for Wireless Communication", Prentice Hall, 2003.
- [3] B. Pham, "A 1.9GHz Gilbert Cell Mixer in 0.18 μ CMOS for a Cable Tuner", Carleton University, 2001.
- [4] S. Rose, "A CMOS sub-harmonic mixer for WCDMA", MS Thesis, University of California, Berkeley, March 2002.
- [5] H. L. Krauss, C.W. Bostian, "Solid State Radio Engineering", John Willey & Sons, 1980.
- [6] T. H. Lee, "The design of CMOS Radio-Frequency Integrated Circuit", Cambridge University Press, 1998.
- [7] B. Razavi, "RF Microelectronics", Prentice Hall, 1998.
- [8] A. A. Abidi, "Direct-conversion radio transceivers for digital communications," *IEEE Journal of Solid-State Circuits*, Vol. 30, pp. 1399–1410, Dec. 1995.
- [9] L. A. NacEachern and T. Manku, "A charge-injection method for Gilbert cell biasing," *IEEE Canadian Conference on Electrical and Computer Engineering*, vol. 1, pp. 365–368, May 1998.
- [10] J.H. Tsai, P.S. Wu, C.S. Lin, T.W. Huang, J.G.J. Chem, W.C. Huang, "A 25-75 GHz Broadband Gilbert-Cell Mixer Using 90-nm CMOS technology", *IEEE Microwave and Wireless Components Letters*, Vol. 17, No. 4, pp. 247-249, April 2007.
- [11] C. S. Lin, P. S.Wu, H. Y. Chang, and H. Wang, "A 9–50-GHz Gilbert cell down-conversion mixer in 0.13 μ m CMOS technology," *IEEE Microwave and Wireless Components Letter*, Vol. 16, No. 5, pp. 293–295, May 2006.
- [12] S. G. Lee and J. K. Choi, "Current-reuse bleeding mixer", *IEEE Electronics Letters*, vol. 36, no. 8, pp. 696–697, Apr.2000.
- [13] C.C. Tang, C.H. WU, W.S. Feng, S.I. Liu, "A 2.4GHz Low Voltage CMOS Down-Conversion Double-Balanced Mixer", *Proc. IEICE Trans, Electron*, vol.E84-c, No. 8, pp.1084-1091, 2001.