

2D Human Motion Regeneration with Stick Figure Animation Using Accelerometers

Alpha Agape Gopalai, and S. M. N. Arosha Senanayake

Abstract—This paper explores the opportunity of using tri-axial wireless accelerometers for supervised monitoring of sports movements. A motion analysis system for the upper extremities of lawn bowlers in particular is developed. Accelerometers are placed on parts of human body such as the chest to represent the shoulder movements, the back to capture the trunk motion, back of the hand, the wrist and one above the elbow, to capture arm movements. These sensors placement are carefully designed in order to avoid restricting bowler's movements. Data is acquired from these sensors in soft-real time using virtual instrumentation; the acquired data is then conditioned and converted into required parameters for motion regeneration. A user interface was also created to facilitate in the acquisition of data, and broadcasting of commands to the wireless accelerometers. All motion regeneration in this paper deals with the motion of the human body segment in the X and Y direction, looking into the motion of the anterior/ posterior and lateral directions respectively.

Keywords—Motion Regeneration, Virtual Instrumentation, Wireless Accelerometers.

I. INTRODUCTION

MOTION analysis methods are mostly depended on vision systems. However, this approach is often not practical in a sports training situation, because these vision system methods are time consuming to obtain results for sports performance analysis. It is due to this reason that the work in this paper was investigated, namely to shorten the period of time required for coaches to obtain required results for coaching purposes.

Motion analysis is very important for sports performance enhancement and injury prevention. Accelerometer has been proven to be a very useful for short term supervised monitoring and long term unsupervised monitoring [1]. Accelerometers have the advantage being resilient and robust in trying conditions, which makes it ideal to perform motion analysis on different types of sports [2]. Tri-axial accelerometers provide information on the acceleration in three planes, namely the vertical plane (Z-axis), anterior and posterior (Y-axis) and lateral direction (X-axis).

The need for a system that is capable of acquiring and

processing data in real time is clear. A soft real time system is a system that would still be able to perform, with minor degradation, if deadlines are not met. The type of system that a human motion analysis system would require, in the interest of cost and complexity, is ideally a soft real time system. Current available systems for accelerometry systems are restrictive when applying the system in real time. Outputs from these available systems are still in the raw accelerometer's data format – 'accelerobits'. Data conversion within the existing system is impossible and has to be done separately (post-processing) which puts a heavy time requirement tag on the system.

The accelerometry system developed in this paper is capable of retrieving data from the accelerometers in real time (soft real time) using virtual instrumentation techniques. These acquired data is then conditioned and processed with a relatively small and constant time requirement, within a single platform. Making the processed data available in the shortest possible time is essential in this application for the coaches/end user, to provide effective and meaningful feedback to the players [3]. Due to the nature of the end user, an interface that is capable of facilitating all wireless commands broadcast and data acquisition is required. This interface is to be simple and straight forward, which allows end user some level of freedom to set data-logging parameters and to view graphical representation of acquired data, as well as the stick figures displaying the regenerated figure.

II. HARDWARE DESCRIPTION

The device used to collect gait/motion data for the analysis methods consists of a G – Link tri-axial wireless accelerometer 5/10g that consists of 3 ADXL 210E accelerometers, which gives the unit 3 measuring axes. It is compact in size (25mm x 25mm x 5mm) which makes it possible for placement at critical points of interest on the subjects body without obstructing the natural motion of the subject, 2 MB of on board memory storage (stores up to 1 million data points), low power requirement – 9 Volt.

The accelerometers were placed on the test subject's body at points of interest, to measure the acceleration at that point; the accelerometers were strapped down to the test subject's body using elastic body straps. The accelerometers has to be securely strapped down to the test subject's body to ensure that the measurement obtained is purely due to the movement of the test subject and not due to the movement of the accelerometers within the body straps (noise) [4] and [5]. Fig.

Manuscript received March 31, 2008. This work was supported in part by Monash University, Sunway Campus.

Alpha Agape Gopalai is with Monash University Sunway Campus, Jalan Lagoon Selatan, 46150 Bandar Sunway (e-mail: agape84@gmail.com).

S. M. N. Arosha Senanayake is with Monash University Sunway Campus, Jalan Lagoon Selatan, 46150 Bandar Sunway (DID - +603 5514 6249; fax-+603 5514 6207; e-mail: Senanayake.namal@eng.monash.edu.my).

1 shows the measuring axes of the accelerometers, and Fig. 2 shows the various placements of the accelerometers on the test subjects' body.

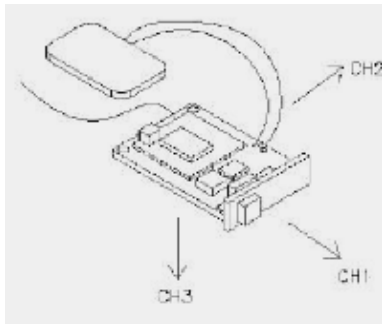

Fig. 1 The Accelerometer

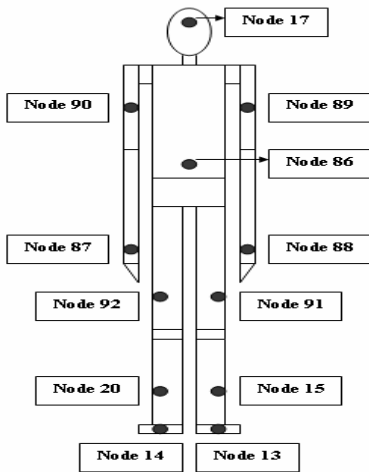

Fig. 2 Accelerometer Placements

The wireless sensors' establishes communication with a PC via a USB base station, Fig. 3, using radio frequency of 900 MHz as its communication medium. The USB base station attached to a computer enables end user to issue various commands to the accelerometers via the USB base station.

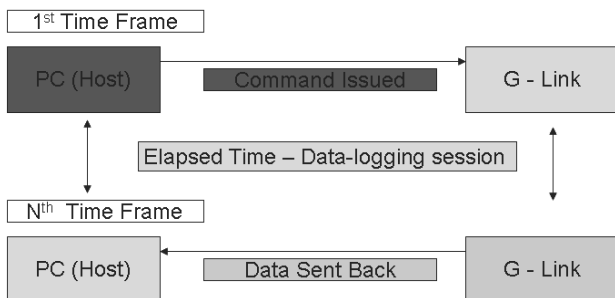

Fig. 3 Flow of data during a trigger session

III. SYSTEM REQUIREMENT AND CAPABILITIES

The basic requirement of the system is for real time (soft) data streaming to be conducted. The streamed data should be processed and interpreted for the ease of the end user. A

graphical representation of the data set is also required, to help facilitate the end user in monitoring gait patterns of the test subject.

A PC based accelerometry system was developed to obtain human motion (gait) data in real time from accelerometers that are physically attached to a test subject's body. Accelerometers communicate via Radio Frequency (RF) to the PC. Data obtained from accelerometers is then conditioned and converted into appropriate kinematical parameters and outputs, which then are displayed in a graphical form for ease of interpretation (numerical also available), the key feature in the designed system is, the systems runs on a single programming platform from the initial processes, data acquisition, to the its final processes if data interpretation.

The designed system will also be capable of performing 2 dimensional motion regeneration of the test subject on the similar programming platform. Motion of the subject will be recorded during the data logging session and plotted/ reconstructed in real time. The reason motion reconstruction is included as a feature of the system, is to enable the end user to make a better judgment/ observation on the motion of the test subject and to provide immediate and effective feedback to the subject if the end user may have detected a flaw in the motion or position of the test subject's body segments.

IV. DATA ACQUISITION METHODS

Data Acquisition is easily carried out with the aid of *LabVIEW VISA (VISA)* programming function that facilitates the communication of the accelerometer and PC, via the USB base station. The *VISA* function along with other functions such as the 'type cast', that converts ASCII codes to HEX values has allowed for significant progress to be made in this paper. The data acquisition method used for obtaining data in this paper is called Triggering. The following section will discuss the data acquisition method and its raw output data format in detail.

A. Triggering

When the trigger command is initiated by the user, the corresponding HEX values for this command will be generated, and transmitted via RF to the accelerometers at a remote location (test subject's body). This command then activates (Triggers) the sensor to begin performing a data logging session for a period of time specified by the user, within the software interface. During the entire process of data logging, data will be recorded onboard the sensor, as depicted in Fig. 4, and will be transmitted back to the computer via radio frequency for further processing.

The triggering function is designed to run indefinitely, whereby at the end of a data logging session the sensor would begin triggering once again until the user instructs it to turn off. The flow diagram in Fig. 5 depicts the designed triggering process. This feature allows for continuous monitoring of gaits to be carried out, and to monitor their dynamical properties.

Raw data obtained from the sensor, are in terms of byte streams, these byte streams are in ASCII format and have to be converted to the HEX values before converting into their

decimal representation as they are arranged in terms of Most Significant Bits (MSBs) and Least Significant Bits (LSBs) in alternating order. Converting these HEX values to Decimal values requires nothing more than a simple step as formulated in (1).

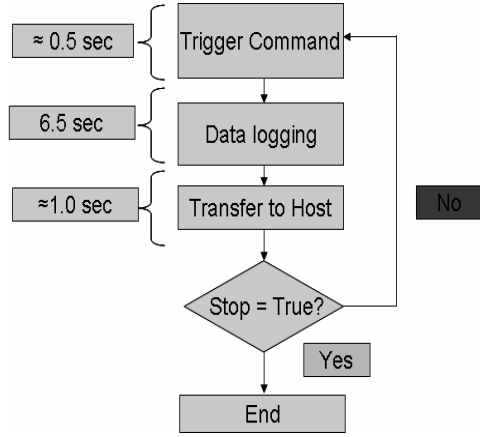

Fig. 4 Process flow for capturing data

$$Decimal = (MSB_byte * 256) + LSB_byte \quad (1)$$

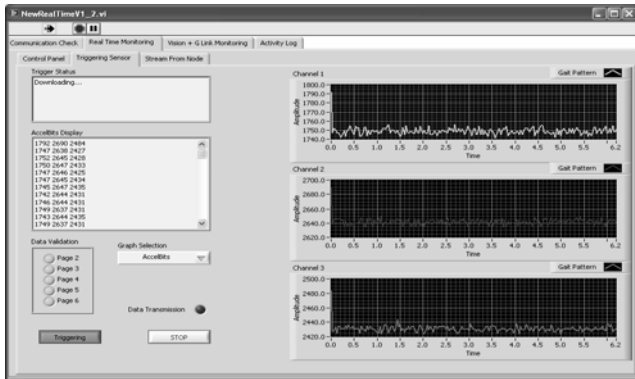

Fig. 5 Data Acquisition Panel

Once data has been converted from HEX to Decimal, the data is now represented as ‘accelerobits’ and is not a representation of acceleration as yet. In order to convert ‘accelerobits’ into a kinematical parameter such as acceleration, then the procedure as shown in (2) has to be carried out. The offset and gain values found in (2) refers to the calibration values of the accelerometers. These values are readily available when the accelerometers are calibrated, and remain constant till the next re-calibration routine. It is after these conversions that the data is ready to be represented as graphical outputs (Fig. 6). The acceleration obtained is channel specific depending on its orientation with respect to the gravitational field,

$$C1 = \frac{(Accelerobits_C1 - Offset_C1)}{Gain_C1} \times 9.81 \quad (2)$$

$$C2 = \frac{(Accelerobits_C2 - Offset_C2)}{Gain_C2} \times 9.81$$

$$C3 = \frac{(Accelerobits_C3 - Offset_C3)}{Gain_C_3} \times 9.81$$

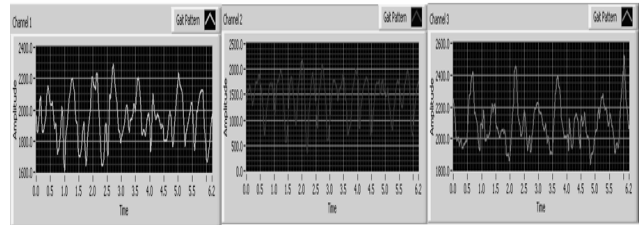

Fig. 6 Graphical Representation of acceleration after conversion in (2)

V. DATA RELIABILITY

When dealing with wireless (RF) data transmission the question to be addressed is the reliability issue of the transmission medium. A method, by which a system ensures that all data have been received, and that there has been no loss of data during transmission, is extremely important to ensure the validity of a certain data set. This section deals with the different methods by which data reliability is ensured for the wireless data transmission of this system.

TABLE I
TRIGGERING HEADER BYTES STRING

Value Pairs	MSB	LSB	(MSB*255) + LSB	Remarks
Bytes 1 & 2	255	255	65535	Fixed Header
Bytes 3 & 4	255	1	65281	Trigger ID
Bytes 5 & 6	5	20	1300	Samples per Data Set during session
Bytes 7 & 8	0	1	1	Internal consecutive session ID
Bytes 9 & 10	0	7	7	Channel mask during session
Bytes 11 & 12	0	4	4	Datalogging Sampling Rate during session

Data is stored on board the sensor in term of pages of 267 bytes in length. When raw data first arrives from the accelerometer, it is in the ASCII format where it will then be converted into its equivalent HEX representation as discussed previously. Once the data is in its HEX representation, the data logging header byte string has to be located; the header byte string is a 12 byte long string that contains user defined setting for the data logging session, such as sweep rate and duration of the data logging session. The first two bytes of this header byte string is always a constant with values of 0xFF. This is the basis used to identify the beginning of the data logging header byte string. Table I shows the representation of

the data in the data logging header byte string.

As indicated in Table I, data is arranged in terms of MSB and LSB, where byte 13 would be the MSB of the information in Channel 1 and byte 14 would contain the LSB of information in Channel 1. Bytes 15 and 16 would be the representation of Channel 2 while bytes 17 and 18, Channel 3. It is then obvious that information of Channel n will be obtained at intervals of 6 packets from its first MSB.

Besides formatting data in this manner, the introduction of a checksum (4) also increases the reliability of the data obtained in terms of error checking. Each page has 2 bytes of checksum (MSB and LSB), these check sums are a representation of the entire data within the page and are represented by equation

$$Check_sum = \frac{\sum(\sum C1, \sum C2, \sum C3)}{65535} \quad (3)$$

The check sum calculation value in (4) will be compared to that which is obtained from the data set using (1) for bytes 266 and 267. If these two values tally then the data in the downloaded data is valid, otherwise the data in the page will not be accepted. Possible errors that could happen in which the system would not be able to correct would be [6]:

- Battery draw-down in the accelerometer
- Radio interference between base station and accelerometers
- Accelerometer's power is switched off
- Out of radio range condition between the base station and the accelerometer.

VI. LAWN BOWLER IN STICK FIGURE

In order to display the results acquired from the accelerometer in terms of a regenerated motion, a stick figure is designed to function with the accelerometer control system. A stick figure is a simple type of drawing to depict the general form of humans. For this paper, a human stick figure is designed for displaying results of motion regeneration.

Some assumptions were made in this paper; the assumptions will be discussed in detail, in the following sections.

A. Right Hand Biased

All the test subject available were right handed players, therefore data for naturally left handed players were unavailable. It would be difficult to predict the way a left hander bowler would bowl so therefore the system is right handed biased.

B. Starting Point for Stick Figure Calculations

All tests that have been done has shown that the tip of the right foot does not move from its position, therefore all calculations for positions will start from the tips of the right foot.

C. Body Length Ratio

The ratio of the length of the body must also be considered

in the development of the stick figure program. Most drawings of the human body take the length of the head as the reference for calculating lengths of different parts of the body, Fig. 7. The average length for the head is assumed to be 230 mm. From the diagram above, the length of the body parts can be summarized in the Table II.

D. Trapezoidal Rules

Readings obtain from the accelerometers are in terms of acceleration. In order to plot the position of each segment the displacement is required. In this paper, a very simple numerical analysis method is employed to convert acceleration to displacement, using the trapezoidal rule by means of double integration.

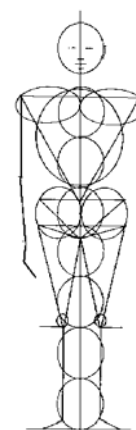

Fig. 7 Body Segment Lengths with Reference to the Head

TABLE II
LENGTH OF BODY SEGMENT

Body Part	Node	Length
Foot	14	Graphical length = 100mm
Shins	15 & 17	2 heads = 230 * 2 = 460mm
Thighs	91 & 92	2 heads = 230 * 2 = 460mm
Chest	20	2 heads = 230 * 2 = 460mm
Upper Arm	87 & 88	1 head = 230 mm
Lower Arm	89 & 90	1 head = 230 mm
Palm	94	Graphical length = 70 mm

VII. MOTION REGENERATION

From the various test conducted, it is concluded that the right foot never moves from its position when a lawn bowler is in motion [7], therefore the tip of the right foot will act as the starting point for the calculations for the stick figure. The calculation for the stick figure involves simple trigonometric functions such as sin and cosine rules.

The initial point of reference was taken to be at node 14 (Fig. 1 – the right foot) and moved upwards from that point to node 20, node 92, node 86, node 91, node 15 and node 13. This covers the calculation for the lower extremity of the

human body, the next stage would be to propagate the calculation upward, using the node situated at the centre of gravity of the human body, approximately at the hip (node 86). With reference to the readings obtained from the node at the hip the position of the two arms was calculated using nodes 90 and 87 for the right arm, while node 89 and 88 for the position of the left arm.

The motion is regenerated and plotted in the LabVIEW programming platform using the graphical output option which is available in LabVIEW. Fig. 8 shows a screen shot of the system plotting the 2D position of a lawn bowler.

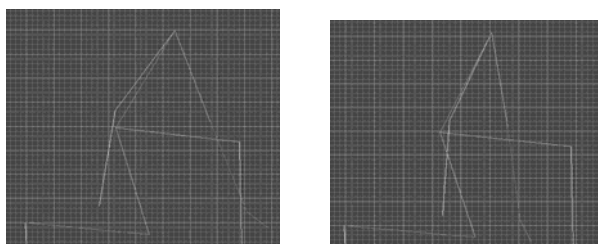

Fig. 8 Motion Regeneration in LabVIEW

VIII. LIMITATION & FUTURE WORK

The major limitation of this setup using only accelerometers is that accurate modelling can only be achieved in 2 dimensions. Although the equipped accelerometers are capable of measuring acceleration in 3 different axes, there has proven to be some limitation in the measurement during the experimental try-outs – Figs. 9 and 10. The limitation of the accelerometers is seen when a test subject is required to perform a certain amount of rotation on a certain body segment of the body while in motion [8]. All translation information can be accurately obtained, however when looking into the rotation of the body segment, the signals produced by the accelerometers do not produce much useful information.

In Fig. 9 and accelerometer was attached to the test subject's wrist, where channel 1 was pointing towards the ground, channel 2 points towards the subject's body, and channel 3 points into the arm. A simple motion was tested. The action was to bring the wrist up by 90 degrees, from the graph we can clearly see the angular changes in the readings from 90 degrees to 0 degrees for channel 1 and 0 degrees to 90 degrees for channel 3 – 0 degrees is assumed to be on the transverse plane. Fig. 10 shows a similar motion, except the motion now requires the arm to be lifted up by 180 degrees. Similar results as in Fig. 9 are observed.

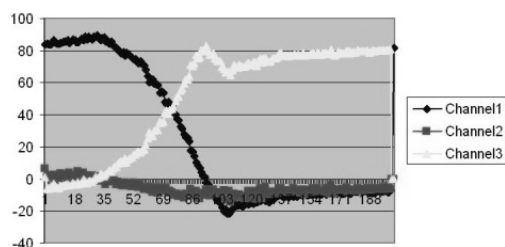

Fig. 9 Graph of Angle vs. Time for a 90 degree motion of the arm

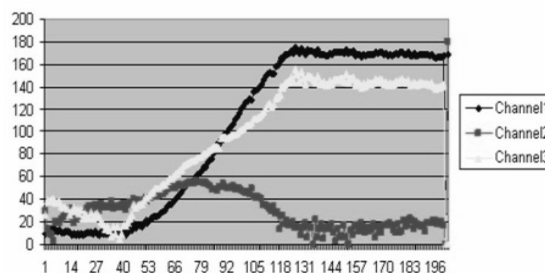

Fig. 10 Graph of Angle vs. Time for a 180 degree motion of the arm

A similar system can be constructed to perform the similar functions as this paper, however the inclusion of an additional type of sensor, gyroscope, is required in order to perform 3 dimensional human motion reconstruction.

IX. CONCLUSION

The position of each joint on the stick figure is obtained from the acceleration-time profile obtained directly from the sensors. The acceleration-time profile is converted first to velocity-time profile by means of numerical integration – Trapezoidal Rule. The displacement-time profile is obtained using the same method described above.

The designed system consists of easy-to-wear sensors to minimize the setup time. It uses minimum number of sensors to fully describe the upper extremities of the lawn bowling motion. The complete motion data of this system is able to be downloaded to a desktop PC via wireless USB base station. The proposed system is demonstrated the use of accelerometers for motion analysis.

In order to have a 3 dimensional motion representation, it is found that dependence on accelerometer readings alone is insufficient to provide a clear picture of the motion that is been monitor. The introduction of a second type of sensor, a gyroscope in particular, may improve the quality of the readings obtain due to its ability to measure the changes in angle with respect to the gravitational field.

REFERENCES

- [1] Merryn J. Mathie, Adelle C. F. Coster, Nigel H Lovell and Branko G Celler, "Accelerometry: providing an integrated, practical method for long-term, ambulatory monitoring of human movement", 2004 *Physiol. Meas.* **25** R1-R20 doi:10.1088/0967-3334/25/2/R01.
- [2] A. A. Gopalai and S.M.N.A Senanayake, "Real Time Instrumented System for Gait Analysis" Computer, Communication and Control Technologies (CCCT), Orlando, Florida, 2007.
- [3] Joel A. Delisa, "Gait Analysis in the Science of Rehabilitation" DIANE Publishing.
- [4] Abu Bakar, B. Amalus, "Real Time Soccer Gait Recognition Using Wireless Sensors and Vision System – Thesis Report", Monash University, Sunway Campus 2005.
- [5] Chong, Vincent "Pattern Classification of a Soccer player's action using wireless sensors – Thesis Report", Monash University, Sunway Campus, 2004.
- [6] MicroStrain "Agile-Link 900MHz Data Communication Protocol, Version 4.0"
- [7] Rod. Judson, "Bio-Mechanics of the Lawn Bowl Delivery Movement" June 2002.
- [8] Bachmann, E.R., Xiaoping Yun, Brumfield, A. "Limitations of Attitude Estimation Algorithms for Inertial/Magnetic Sensor Modules", *IEEE Robotics & Automation Magazine*, September 2007.

Alpha A. Gopalai (M'07) became a Member (M) of IEEE in 2007. The author did his first degree in engineering (Mechatronics) at Monash University Sunway Campus, Malaysia in 2007. The author is currently pursuing his Masters in Engineering Science (Research) at the same campus under the supervision of Arosha Senanayake, in the field of human motion and biomechanics.

Alpha is currently a member of the Intelligent, Integrated and Interactive Systems (IIS). His research interest includes the biomechanics of human motion, and humanoid motion control.

Arosha N. Senanayake (M'05, SM'06) became a Member (M) of IEEE in 2005 and a Senior Member (SM) in 2006. He is currently with Monash University Sunway Campus where he leads the research group Intelligent, Integrated and Interactive Systems (IIS). He has been recently appointed as the chairman of IEEE Asia-Pacific Robotics & Automation Development Council – Malaysia Section. Prior to Monash, he has been working with three different universities; Chalmers University of Technology, Sweden, Johannes Kepler University of Linz, Austria and University of Peradeniya, Sri Lanka holding key academic and research positions. During his 18 years of research experience, he managed to publish over 72 publications in international conferences, journals and book chapters. He was one of the editors of three books published based on the research outcomes. He was the special session organizer for various international conferences, in particular IEEE conferences. He is one of the reviewers in IEEE publications and Elsevier publications.

He has initiated research with Sports Biomechanics Centre, National Sports Complex, in which his research team carried out special research projects of national interest. Having engaged in this area of research, Interactive Multilayer Sensorized Smart Floor has been developed under his leadership and currently in the process of patenting the device. Dr. Arosha is the leader of MoU between Monash and National Instruments. He carried out various special research projects under this MoU which are mainly targeting industrial needs.

He is a member of research committee of Monash and he is the student counselor of IEEE student branch at Monash.