

# Real Time Force Sensing Mat for Human Gait Analysis

Darwin Gouwanda, S. M. N. Arosha Senanayake, M. M. Danushka Ranjana Marasinghe, Mervin Chandrapal, Jeya Mithra Kumar, Tung Mun Hon, and Yulius

**Abstract**—This paper presents a real time force sensing instrument that is designed for human gait analysis purposes. This instrument mainly consists of three main elements: the force sensing mat, signal conditioning and switching circuit and data acquisition device. In order to control and to process the incoming signals from the force sensing mat, Force-Logger and Force-Reloader program are developed using Labview 8.0. This paper describes the architecture of the force sensing mat, signal conditioning and switching circuit and the real time streaming of the incoming data from the force sensing mat.

**Keywords**—Force platform, Force sensing resistor, human gait analysis.

## I. INTRODUCTION

AS the study on biomechanics is growing, various methods and tools have been developed to collect either dynamics or kinematics parameters of the human gait. And force platform emerges as one of the most common tools used to provide information on three orthogonal forces and moments exerted by human body. It is widely used in engineering and medical research, orthopedics, rehabilitation evaluation, prosthetics and other general industrial uses. If it is mounted properly, force platform is a very reliable and accurate device.

However, despite of its capabilities and performances, force platform has several limitations. One of its limitation is that force platform does not provide either qualitative or quantitative information on how the ground reaction forces are distributed on the human foot, from toe to heel. Therefore, due to this reason, engineers and other various field researchers have designed and developed force sensing mat that is capable to visualize the force distribution of the human feet. Paradiso, et al used Polyvinylidene Fluoride polymer (PVDF) wires to develop a magic carpet that is capable of measuring human foot pressure [1]. Srinivasan, et al developed a pressure sensing floor that has one sensor per square centimeter, with sensor spaced 10 mm apart and each sensor has active area of 6 mm x 6 mm [2].

With similar functionalities as the force sensing mat mentioned earlier, a real time force sensing instrument that has different concept is introduced in this paper. This instrument contains an array of force sensing elements that is capable of monitoring and recording the movement pattern of a test subject in standing, walking, jumping and running. Additionally it is able to provide qualitative information on how the vertical ground reaction forces are exerted on each part of the human foot i.e. toe, middle foot and heel.

## II. FORCE SENSING MAT ARCHITECTURE

There are two similar force sensing mats have been developed. Each force sensing mat contains 144 Force Sensing Resistors (FSR) that are distributed evenly on 480 mm x 540 mm acrylic board. And each force sensing platform has an effective sensing area of 480 mm x 480 mm.

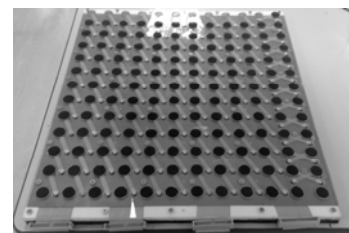

Fig. 1 Force Sensing Platform

In addition, each force sensing mat has a total of 5 layers that serve different purposes. The first layer is 3mm thick acrylic board with 144 through holes to expose the sensing area of the sensors. The second layer is a customized Printed Circuit Board (PCB) that connects the sensing elements to four 40 ways connectors where the links between the mat and the signal conditioning circuit is established. The third layer is a rubber mat that protects the connection beneath the circuit

Manuscript received April 9, 2008. This work was supported under Mechatronics Project II by Monash University Sunway Campus.

Darwin Gouwanda is with Monash University Sunway Campus as a Research Student leading to Master's Degree in Engineering Science (phone: +603 - 551461852; fax: +603 - 55146249; e-mail: darwin\_gouwanda@yahoo.com).

Namal A. Senanayake is with the Monash University Sunway Campus, Malaysia since 2002 (phone: +603-55146249; fax: +603-55146207; e-mail: senanayake.namal@eng.monash.edu.my).

M. M. Danushka Ranjana Marasinghe is currently with Monash University Sunway Campus pursuing Bachelor's degree in Mechatronics Engineering.

Mervin Chandrapal is currently with Monash University Sunway Campus pursuing Bachelor's degree in Mechatronics Engineering.

Jeya Mitra Kumar is currently with Monash University Sunway Campus pursuing Bachelor's degree in Mechatronics Engineering.

Tung Mun Hon is currently with Monash University Sunway Campus pursuing Bachelor's degree in Mechatronics Engineering.

Yulius is currently with Monash University Sunway Campus pursuing Bachelor's degree in Mechatronics Engineering.

board. And lastly, the fourth layer is a combination of thick acrylic board and rubber mat. Acrylic board ensures the stability and rigidity of the platform while rubber mat prevents the platform from sliding when test subject performs his/her activities.

Since both force sensing platforms utilize similar sensing elements and has similar dimensions with same effective sensing area, both platforms can be arranged to form a larger platform with dimension of 960 mm x 540 mm. And this arrangement is able to provide a larger movement area for the test subject to perform his activities.

III. SIGNAL CONDITIONING CIRCUIT

In overall, there are two major electrical circuitries. Both circuitries have their own functionality and purposes. The first electrical circuitry is the signal conditioning circuit. As the name implies, it contains numerous operational amplifiers that condition and amplify the incoming signals from the force sensing mat.

Since the data acquisition device only has limited analog inputs, switching circuit is implemented. It contains numerous multiplexers that are able to switch the readings among the 144 force sensing elements. Furthermore, to accommodate the readings of incoming signals, a double layer switching method is introduced. In this method, the force sensing platform is divided into 4 main regions. Each region has 36 sensing elements that are arranged in array. In the first layer of switching method, each layer has a total of six multiplexers which are in charge of switching readings among 36 sensing elements. In second layer, output signals from the multiplexers are then multiplexed and transmitted to data acquisition device using a single multiplexer.



Fig. 2 Signal Conditioning Circuit

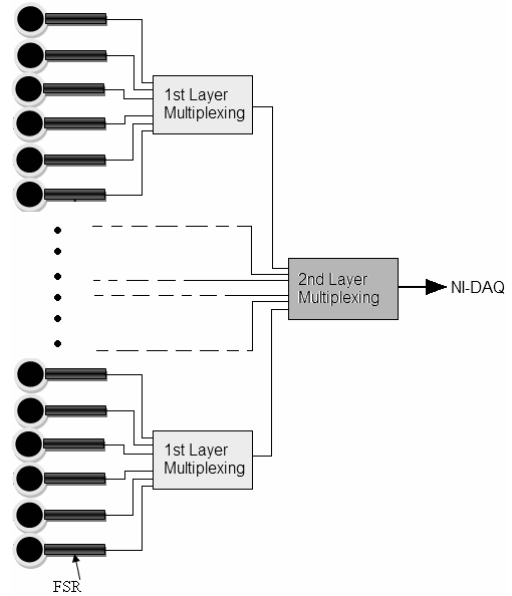

Fig. 3 Schematic diagram of double layer switching method for one region

The 144 sensors on the platform have been divided into four quadrants of 36 sensors each. Each quadrant will provide one output to the Data Acquisition (DAQ) device. The sensors were arranged in a 6x6 matrix order. These will be multiplexed in two stages as shown in Fig. 4.

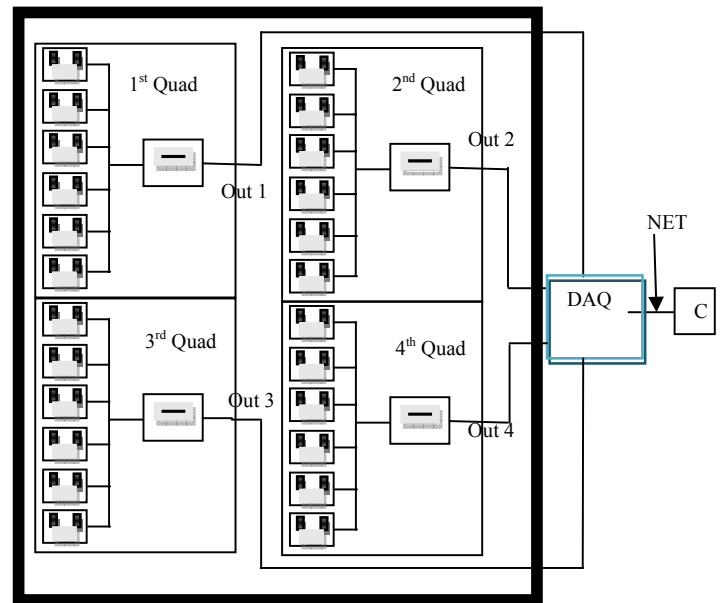

Fig. 4 Schematic diagram of arrangements of sensors into quadrants with connectivity to the ethernet

The state one of the multiplexing is the row selection. In the 6x6 matrix arrangement a single multiplexer is assigned to control one row (6 sensors). Two op-amps and 6 channels of a single multiplexer are used in the row selection process. There will be six outputs for 36 sensors (1 quadrant). The state two is row selection. The 6 outputs from the row

selection circuit are then multiplexed by using a single multiplexer. This acts as a column selector. When a digital state is selected in this multiplexer it will correspond to the particular row of stage one. The outputs from each quadrant will feed into the DAQ. The DAQ will then transfer the relevant data to the PC through Ethernet port.

Therefore, scanning sensor data from columns and rows will be done based on the following flow chart in Fig. 5.

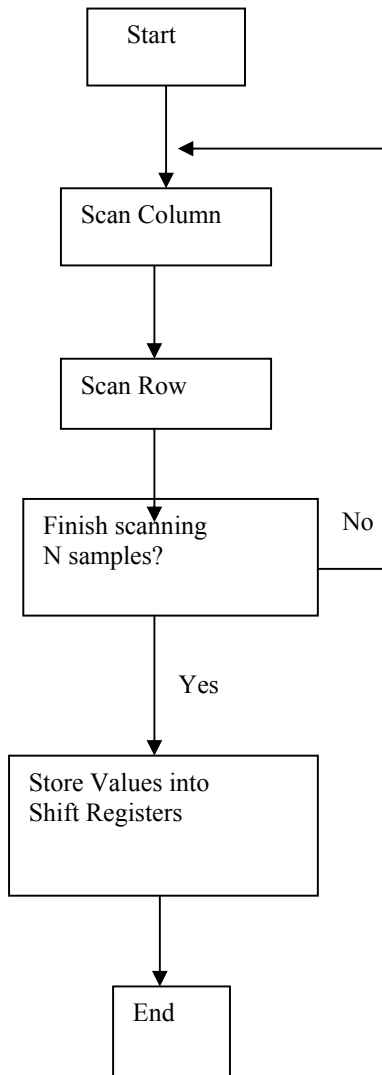

Fig. 5 Scanning process at the hardware level

Therefore, complete switching and multiplexing circuits of have been built and located in different control boxes as shown in Fig. 6. Fig. 6 shows the complete force mat with four control boxes.

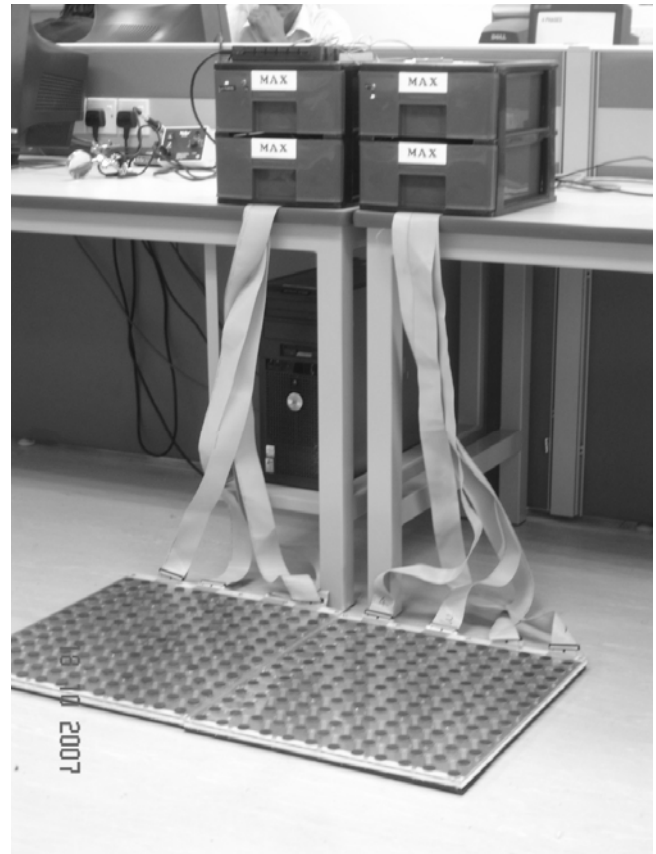

Fig. 6 Complete force platforms with four control boxes

#### IV. REAL TIME STREAMING THROUGH DATA ACQUISITION DEVICE

Real time streaming from the force sensing platform is achieved by using NI PCI-6070E Data Acquisition card (DAQ). This device is able to receive the incoming signal from the signal conditioning and switching circuit, perform analog-to-digital conversion and transmit them to a computer for further processing procedures.

To visualize the incoming signals from the platforms interactively, Force-Logger and Force-Reloader are developed using National Instrument LabVIEW as shown in Fig. 7. Both, software modules are capable of providing qualitative information on how ground reaction forces are exerted on each part of the foot i.e. toe, middle foot and heel. This information is essential as it is able to determine whether the test subject has good gait posture and to determine whether the test subject is exerting the correct amount of force on each part of the foot in walking, running and jumping. Additionally, both programs have similar features and Graphical User Interface (GUI) so that user that is familiar with Force-Logger is able to operate Force-Reloader and vice versa, without facing any difficulties. The only difference between Force-Logger and Force-Reloader is that Force-Logger is used to stream, process and display the incoming data graphically while Force-Reloader is used to reload the experiment data taken previously.

**A. Force-Logger**

Force-Logger is software that is capable of streaming, processing and displaying the incoming data graphically in real time. Based on the incoming data, Force-Logger is able to measure the maximum and minimum applied force, the jumping flight time and maximum jumping height. Additionally, Force-Logger will record the test subject's details i.e. name, age, height and weight and the time and date when the experiment is conducted.

To accommodate one of the strong features, where two force sensing mats can be merged to one mat to provide larger sensing area, Force-Logger has two different operational modes: single mode and combined mode. In single mode, each force sensing mat is treated individually as shown in Fig. 7. The signal acquisition and analysis are performed separately. In combined mode, both force sensing mat are merged to one and treated as one large sensing mat as shown in Fig. 8.

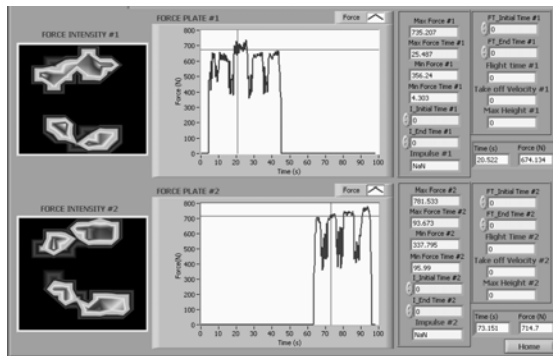

Fig. 7 Force-Logger in single mode

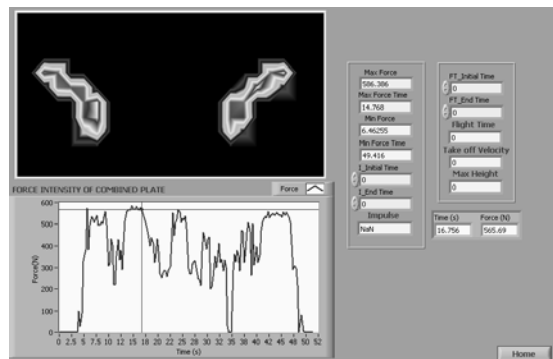

Fig. 8 Force-Logger in combine mode

**B. Force-Reloader**

Second software, Force-Reloader is used to load the experiment data taken previously. It displays the test subject's details i.e. names, age, height and weight, time and date when the experiment was conducted, the operational mode, and the force distribution data. Once the data is completely loaded, user can easily perform required analysis such as maximum and minimum applied forces, jumping flight time and maximum jumping height as well.

**C. Software Architecture**

The program codes designed for the force platforms perform three tasks sequentially when it is executed. The first task is to get the relevant data which from the data acquisition circuit via DAQ card. The data of interest here is the voltage values when there are forces exerted on the force platform. The second task is to convert the voltages obtained to appropriate force values and finally the third task is to display the information of the forces on the front panel. The full program codes can be summarized into the following main modules;

1. Prompt the user to key in relevant information, such as mass and number of samples to be taken as well as choose a specific activity to obtain the desired outputs
2. Scan the force platforms and obtain the voltage data from DAQ. The voltages are then converted into force values
3. Determine the total force exerted on both platforms at any instant
4. Compute instantaneous force information, such as maximum force, minimum force and mean force exerted on both platforms
5. Displays the force information in waveforms and intensity graphs for both platforms after each successive session
6. Stores the data obtained into a folder specified in a computer
7. Compute the parameters of the specific activity based on the force data obtained. For example, the hang time, take-off velocity for jumping activity
8. Display the computed parameters on the front panel
9. Replay simulation using the data stored earlier if the user wish to review back the simulation

In order to implement all above modules, interactive Graphical User Interface (GUI) was developed. GUIs developed can be divided into two main modules; run simulation and replay simulation. Run simulation GUI is shown in Fig. 9.

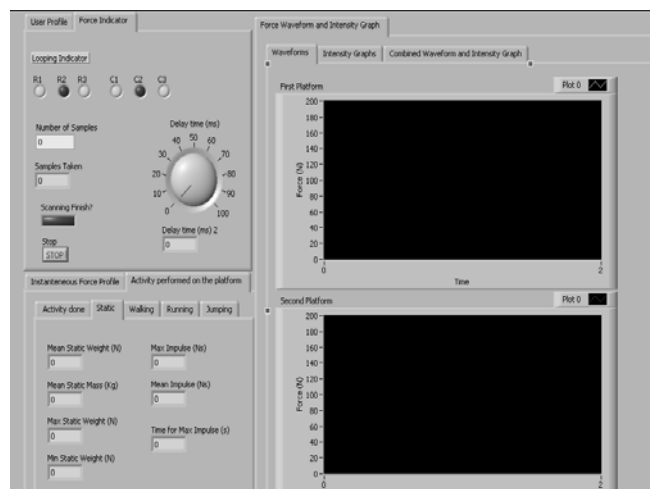

Fig. 9 Run Simulation Module

This GUI is divided into three main sub GUIs. One sub GUI is to deal with user profile and force indicator. Second sub GUI is to visualize waveforms (signals), Intensity Graphs and as well as for combined platforms visualization. Third sub GUI provides all derived parameters from force sensing data during walking, jumping and running.

Replay simulation GUI provides similar functions as run simulation GUI with fundamental difference of visualizing data based on previously stored data as shown in Fig. 10.

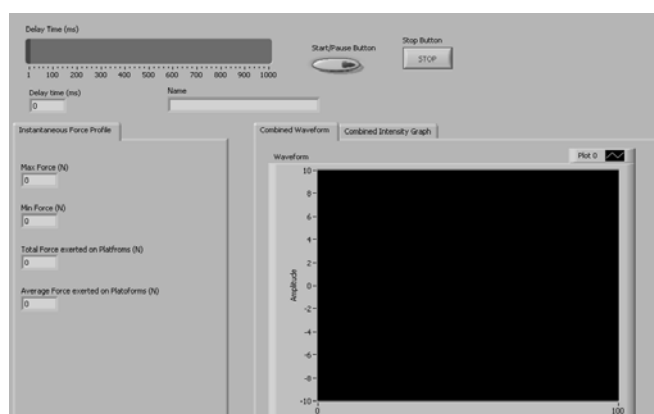

Fig. 10 Replay Simulation Module

## V. ACTIVITIES ON FORCE SENSING MAT

There are several activities have been performed on the force sensing platform. These activities include standing walking, running and jumping. Additionally, for jumping event, one leg jump, two leg jump and counter movement jump experiment have been considered as well. These experiments have been carried out successfully on 25 test subjects. In each experiment, test subjects are instructed to perform activities mentioned above in bare feet. Samples of force distributions of the human feet in several activities are shown in Figs. 11 and 12 below.



Fig. 11 Force distribution of human feet in standing

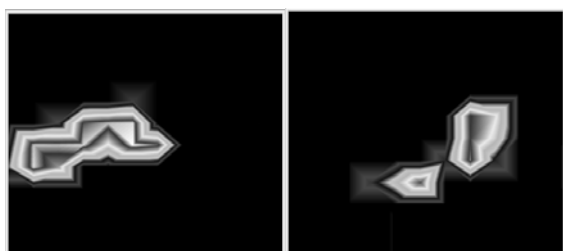

Fig. 12 Force distribution of human foot in one leg jump

One of the preliminary experiment dataset which contains data of 6 test subjects is presented in Table I and Table II. This dataset contains information on test subjects' jumping activities i.e. maximum jumping height (JH), jumping takeoff velocity (JV) and jumping flight time (JT).

TABLE I  
EXPERIMENT DATASET ON ONE LEG JUMP

No.	Weight (Kg)	Height (m)	JV(m/s)	JH(m)	JT(s)
1	51.70	163	1.518	0.112	0.312
2	57.00	163	1.393	0.107	0.281
3	62.60	165	1.711	0.152	0.351
4	69.10	170	1.772	0.161	0.366
5	74.00	175	1.621	0.138	0.442
6	76.50	179	1.675	0.142	0.349

TABLE II  
UNITS FOR MAGNETIC PROPERTIES

No.	Weight (Kg)	Height (m)	JV(m/s)	JH(m)	JT(s)
1	51.70	163	1.581	0.132	0.318
2	57.00	163	2.590	0.371	0.741
3	62.60	165	2.471	0.346	0.498
4	69.10	170	2.293	0.299	0.472
5	74.00	175	3.651	0.679	0.739
6	76.50	179	2.221	0.280	0.451

From Table I and Table II, it can be observed that different test subjects have different jumping capabilities regardless of their height and weight. By comparing Table I and Table II, it can be seen that all test subjects are able to jump higher and achieve larger takeoff velocity and longer jumping flight time in counter movement jump. Another observation that can be perceived is that real-time force sensing instrument is performing well in monitoring and recording human motion such as walking, running and jumping, in real time.

## VI. CONCLUSION

FSR, as force sensing elements have been successfully implemented in the force sensing mat. Array of FSR on the acrylic board has given effective force sensing area with dimension of 480 mm x 540 mm. It is able to display the force distribution of human feet in various activities. Furthermore, data acquisition device from National Instrument has enabled the real time monitoring of the foot pressure in standing, walking, running and jumping. Lastly, experiments results are satisfactory. And it shows that force sensing mat has a promising prospect. It clearly indicates that it can be used in various fields, such as sports, clinical rehabilitation and research as well as surveillance and security system.

## REFERENCES

- [1] J. Paradiso, C. Ablar, K. Y. Hsiao, M. Reynolds, "The Magic Carpet: Physical Sensing for Immersive Environments", *Proc. of the CHI '97 Conference on Human Factors in Computing Systems*, ACM Press, NY, 1997, pp 277-278.
- [2] P. Srinivasan, G. Qian, D. Birchfield, Kidanè A., "Design of a Pressure Sensitive Floor for Multimodal Sensing" *Proceedings of the*

*International Conference on Non-visual & Multimodal Visualization*, London, UK, 2005.

- [3] T. Lee, Y. Kwon, H. Kim, "Smart Location Tracking System using FSR (Force Sensing Resistor)" *International Conference on Artificial Reality and Telexistence*, Coex, Korea, 2004.
- [4] J. O. Robert, "Smart Floor: Future Computing Environments", available at <http://www-static.cc.gatech.edu/fce/smartfloor/>

**Darwin Gouwanda** received his degree in mechatronics engineering from Monash University Sunway Campus, Malaysia in 2006. The author is currently pursuing his Masters of Engineering Science (Research) under supervision of Dr. Arosha Senanayake. His research areas include human biomechanics and gait analysis, sports engineering and artificial intelligence.

**Namal A. Senanayake** is currently with Monash University Sunway Campus where he leads the research group Intelligent, Integrated and Interactive Systems (IIIS). He has been recently appointed as the chairman of IEEE Asia-Pacific Robotics & Automation Development Council – Malaysia Section. Prior to Monash, he has been working with three different universities; Chalmers University of Technology, Sweden, Johannes Kepler University of Linz, Austria and University of Peradeniya, Sri Lanka holding key academic and research positions. During his 18 years of research experience, he managed to publish over 72 publications in international conferences, journals and book chapters. He was one of the editors of three books published based on the research outcomes. He was the special session organizer for various international conferences, in particular IEEE conferences. He is one of the reviewers in IEEE publications and Elsevier publications.

He has initiated research with Sports Biomechanics Centre, National Sports Complex, in which his research team carried out special research projects of national interest. Having engaged in this area of research, Interactive Multilayer Sensorized Smart Floor has been developed under his leadership and currently in the process of patenting the device. Dr. Arosha is the leader of MoU between Monash and National Instruments. He carried out various special research projects under this MoU which are mainly targeting industrial needs.

Dr. Senanayake is a member of research committee of Monash and he is the student counselor of IEEE student branch at Monash.

**M. M. Danushka Ranjana Marasinghe** is currently pursuing his bachelor degree in mechatronics engineering at Monash University Sunway Campus.

**Mervin Chandrapal** is currently pursuing his bachelor degree in mechatronics engineering at Monash University Sunway Campus.

**Jeya Mithra Kumar** is currently pursuing his bachelor degree in mechatronics engineering at Monash University Sunway Campus.

**Tung Mun Hon** is currently pursuing his bachelor degree in mechatronics engineering at Monash University Sunway Campus.

**Yulius** is currently pursuing his bachelor degree in mechatronics engineering at Monash University Sunway Campus.