

# Electric Field and Potential Distributions along Surface of Silicone Rubber Polymer Insulators Using Finite Element Method

B. Marungsri, W. Onchantuek, and A. Oonsivilai

**Abstract**—This paper presents the simulation the results of electric field and potential distributions along surface of silicone rubber polymer insulators. Near the same leakage distance subjected to 15 kV in 50 cycle salt fog ageing test, alternate sheds silicone rubber polymer insulator showed better contamination performance than straight sheds silicone rubber polymer insulator. Severe surface ageing was observed on the straight sheds insulator. The objective of this work is to elucidate that electric field distribution along straight sheds insulator higher than alternate shed insulator in salt fog ageing test. Finite element method (FEM) is adopted for this work. The simulation results confirmed the experimental data, as well.

**Keywords**—Electric field distribution, potential distribution, silicone rubber polymer insulator, finite element method.

## I. INTRODUCTION

POLYMER insulators, which are being used increasingly for outdoor applications, have better characteristics than porcelain and glass types: they have better contamination performance due to their surface hydrophobicity, lighter, possess higher impact strength, and so on. However, since polymer insulators are made of organic materials, deterioration through ageing is unavoidable. Hence, ageing deterioration is a primary concern in the performance of polymer insulators. Artificial salt fog ageing tests have been most widely conducted on simple plates, rods, and small actual insulators for evaluating the anti-tracking and/or anti-erosion performance of housing materials for polymer insulators [1–7].

In previous work, salt fog ageing test have been conducted on specimens having different configurations [8]. Although tested specimens having the same leakage distance and made of the same material, obviously degree of surface ageing on tested specimens was obtained. Fully results and discussions are found in [8]. However, briefly results are illustrated in Section II.

In order to elucidate the effect of specimen configuration in the view point of electric field and potential distributions

along the specimen surface, Finite Element Method (FEM) is adopted as mathematical tool for simulation electric field and potential distributions.

## II. ARTIFICIAL SALT FOG AGEING TEST RESULTS

Two insulator-type specimens, having straight and alternate sheds, were prepared as shown in Fig. 1. All the specimens were made of high-temperature vulcanized silicone rubber (HTV SiR) with alumina trihydrate (ATH:  $\text{Al}_2\text{O}_3 \cdot 3\text{H}_2\text{O}$ ) filler contents of 50 parts per 100 by weight (pph). The insulator-type specimens were prepared by molding HTV SiR onto the FRP rods. Molding lines or parting lines were found on these insulator-type specimens. Two pieces of each specimen type were used in this investigation. All specimen surfaces were cleaned by ethyl alcohol 24 hours before starting the test.

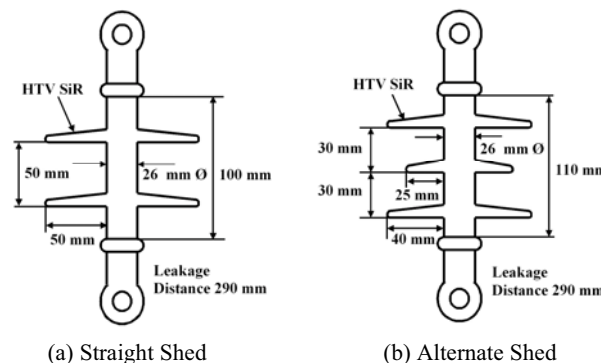

Fig. 1 Test Specimens

All specimens were hung vertically in a plastic chamber as shown in Fig. 2 and were tested together under the test conditions shown in Table I. The cyclic salt fog ageing test was conducted by injecting salt fog into the chamber for 8 hours and stopping it for 16 hours every day under AC 15kV. The salt fog, with a salinity of  $800 \mu\text{S}/\text{cm}$  and an injection rate of  $0.5 \text{ l}/\text{hr}/\text{m}^3$ , was generated using an ultrasonic humidifier and was injected from the top of the test chamber as shown in Fig. 2. Leakage currents were continuously measured on individual specimens.

B. Marungsri is with Suranaree University of Technology, Nakhon Ratchasima, 30000, Thailand (phone: +66 4422 4366; fax: +66 4422 4601; e-mail: bmsvhee@sut.ac.th).

W. Onchantuek and A. Oonsivilai are with Suranaree University of Technology, Nakhon Ratchasima, 30000, Thailand.

TABLE I  
 TEST CONDITIONS

|                                     |   |  |
|-------------------------------------|---|--|
| Test Chamber                        | 1590 mm×1560 mm ×1330 <sup>H</sup> mm, (2m <sup>3</sup> ) |  |
| Test Voltage                        | AC 15 kV, Continuously Applied                            |  |
| Voltage Stress                      | 60 V/mm for rod type, 51.3 V/mm for insulator types       |  |
| Salt Fog                            | Generation  | Ultrasonic Humidifier (Model WM – B NB 1000) |
|                                     | Injection Rate  | 0.5 l / hr / m <sup>3</sup>                  |
|                                     | Conductivity  | 800 μS / cm                                  |
| Test Sequence in 1 Cycle (24 hours) | Salt fog injected for 8 hours and stopped for 16 hours    |  |

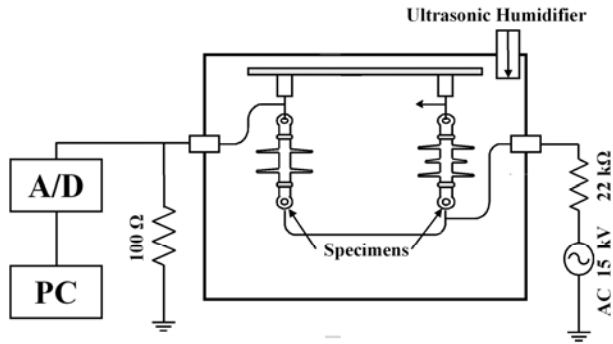
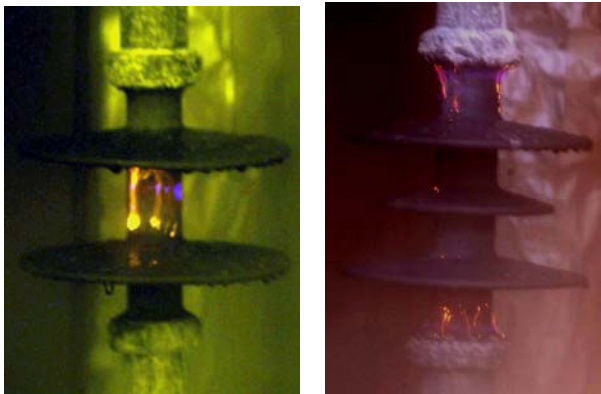
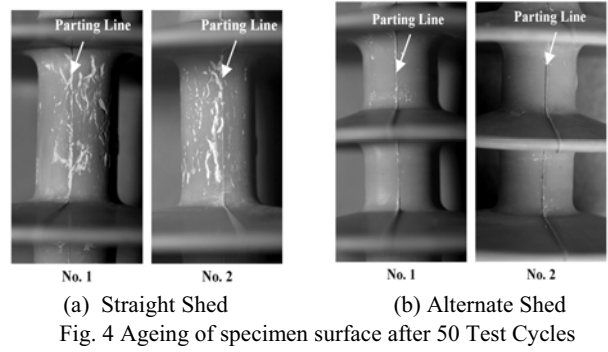

Fig. 2 Test Arrangement

During 50 test cycle of salt fog ageing test, stronger surface discharges were observed on the specimen having straight sheds comparing with the specimen having alternate sheds although all specimens having the same leakage distance and made of the same materials. The observation result is illustrated in Fig. 3. After 50 test cycles, severe surface ageing was observed on the trunk between sheds of specimens having straight shed comparing with the specimen having alternate sheds, as shown in Fig. 4. Considering the results, the assumption is electric field distribution along the specimen having straight shed higher than the specimen having alternated sheds.

 (a) Straight Shed (b) Alternate Shed  
 Fig. 3 Discharge on specimen surface during 50 Test Cycles

 (a) Straight Shed (b) Alternate Shed  
 Fig. 4 Ageing of specimen surface after 50 Test Cycles

### III. NUMERICAL EXPERIMENT

#### A. Equations for Electric Field and Potential Distributions Calculation

Simply way for electric field distribution calculation is calculate electric potential distribution. Then, electric field distribution is calculated by minus gradient of electric potential distribution. Due to electrostatic field distribution, electric field distribution can be written as follows [9]:

$$E = -\nabla V \quad (1)$$

From Maxwell's equation

$$\nabla E = \frac{\rho}{\epsilon} \quad (2)$$

where  $\rho$  is resistivity  $\Omega/m$ ,

$\epsilon$  is dielectric constant of dielectric material

( $\epsilon = \epsilon_0 \epsilon_r$ )

$\epsilon_0$  is air or space dielectric constant ( $8.854 \times 10^{-12}$  F/m)

$\epsilon_r$  is relative dielectric constant of dielectric material

Place equation (1) in equation (2) obtained Poisson's equation.

$$\nabla \epsilon \nabla V = -\rho \quad (3)$$

Without space charge  $\rho = 0$ , Poisson's equation becomes Laplace's equation.

$$\nabla \epsilon \nabla V = 0 \quad (4)$$

#### B. Equations for FEM Analysis of the Electric Field Distribution

The finite element method is one of the numerical analysis methods based on the variation approach and has been widely used in electric and magnetic field analyses since the late 1970s. Supposing that the domain under consideration does not contain any space and surface charges, the two-dimensional functional  $F(u)$  in the Cartesian system of coordinates can be written as follows[10]:

$$F(u) = \frac{1}{2} \int_D \left[ \varepsilon_x \left( \frac{du}{dx} \right)^2 + \varepsilon_y \left( \frac{du}{dy} \right)^2 \right] dx dy \quad (5)$$

where  $\varepsilon_x$  and  $\varepsilon_y$  are the  $x$ - and  $y$ -components of the dielectric constant in the Cartesian system of coordinates and  $u$  is the electric potential. In the case of isotropic permittivity distribution ( $\varepsilon = \varepsilon_x = \varepsilon_y$ ), Equation (5) can be rewritten as

$$F(u) = \frac{1}{2} \int_D \varepsilon \left[ \left( \frac{du}{dx} \right)^2 + \left( \frac{du}{dy} \right)^2 \right] dx dy \quad (6)$$

If the effect of dielectric loss on the electric field distribution is considered, the complex functional  $F(u)$  should be taken as

$$F(u) = \frac{1}{2} \int_D \omega \varepsilon_0 (\varepsilon - j \varepsilon \cdot \tan \delta) \left[ \left( \frac{du}{dx} \right)^2 + \left( \frac{du}{dy} \right)^2 \right] dx dy \quad (7)$$

where  $\omega$  is angular frequency,  $\varepsilon_0$  is the permittivity of free space ( $8.85 \times 10^{-12}$  F/m),  $\tan \delta$  is tangent of the dielectric loss angle, and  $u^*$  is the complex potential.

Inside each sub-domain  $D_e$ , a linear variation of the electric potential is assumed, i.e.

$$u_e(x, y) = \alpha_{e1} + \alpha_{e2}x + \alpha_{e3}y \quad ; (e = 1, 2, 3, \dots, ne) \quad (8)$$

where  $u_e(x, y)$  is the electric potential of any arbitrary point inside each sub-domain  $D_e$ ,  $\alpha_{e1}$ ,  $\alpha_{e2}$  and  $\alpha_{e3}$  represent the computational coefficients for a triangle element  $e$ ,  $ne$  is the total number of triangle elements.

The calculation of the electric potential at every knot in the total network composed of many triangle elements was carried out by minimizing the function  $F(u)$ , that is,

$$\frac{\partial F(u_i)}{\partial u_i} = 0 \quad ; i = 1, 2, \dots, np \quad (9)$$

where  $np$  stands for the total number of knots in the network.

Then we can get a metrical expression

$$[S_{ji}] \{u_i\} = \{T_j\} \quad i, j = 1, 2, \dots, np \quad (10)$$

where  $[S_{ji}]$  is the matrix of coefficients,  $\{u_i\}$  is the matrix vector of unknown values of the potential at the knots and  $\{T_j\}$  is the metrical vector of free terms. The metrical equation (10) can be solved using various methods, including the Gauss-Seidel iterative method.

### C. Implementation for FEM Analysis

The basic design of a polymer insulator is as follows; A fibre reinforced plastic (FRP) core having relative dielectric constant 7.1, attached with two metal fittings, is used as the load bearing structure. Weather sheds made of HTV silicone rubber having relative dielectric constant 4.3 are installed outside the FRP core. Surrounding of the insulator is air having relative dielectric constant 1.0. AC 15 kV is energized on the lower electrode while the upper electrode connected with ground. Two dimensions of the two type polymer insulators for FEM analysis are shown in Fig. 5.

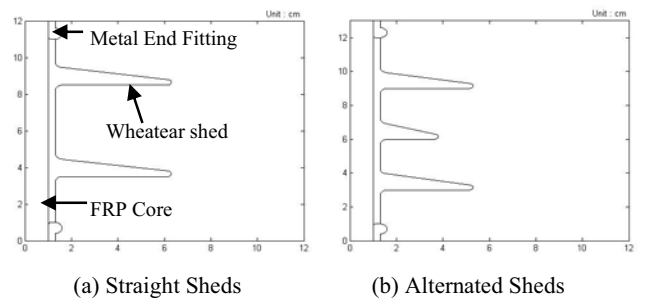
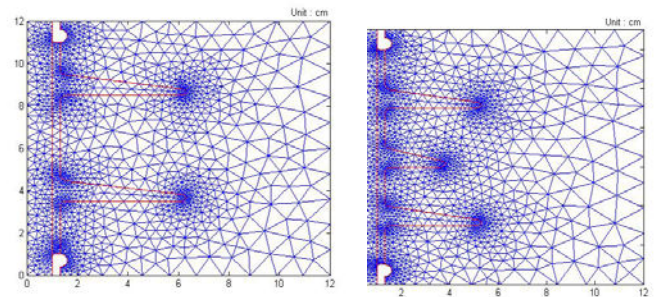

Fig. 5 Two dimension of the two type polymer insulators for FEM analysis

The whole problem domain in Fig. 5 is fictitiously divided into small triangular areas called *domain*. The potential, which is unknown throughout the problem domain, is approximated in each of these elements in terms of the potential in their vertices called *nodes*. Details of Finite Element discretization are found in [12]. The most common form of approximation solution for the voltage within an element is a polynomial approximation. PDE Tool in MATLAB is used for finite element discretization. The obtaining results are 1,653 nodes and 3,180 elements for straight sheds type insulator and 2,086 nodes and 4,030 elements for alternate sheds type insulator, respectively. The obtaining results are shown in Fig. 6



(a) Straight Sheds insulator (b) Alternate Sheds Insulators  
Fig. 6 Finite element discretization results

## IV. SIMULATION RESULTS AND DISCUSSIONS

Clean and contamination conditions are simulated in this study. Potential Distribution results are shown in Fig. 7 and electric field distribution are shown in Fig. 8. Although nonlinear potential distribution along leakage distance of the two type specimens, more nonlinear can be seen on the straight sheds specimen comparing with the alternate shed specimen, as shown in Fig. 9. In spite of clean condition, electric field distribution on the straight sheds specimen is higher than the alternate sheds specimen.

Contamination condition is simulated by place water droplets on the two type insulator surfaces as shown in Fig. 10 and Fig. 12. The simulation results of electric field and potential distributions are illustrated in Fig. 11 and Fig. 13, respectively.

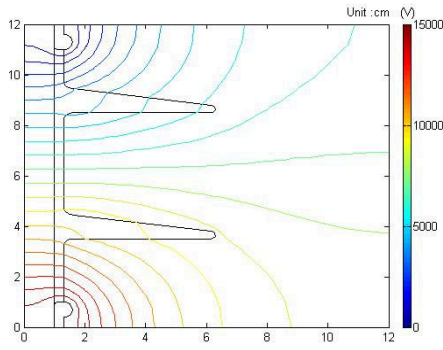

(a) Straight Sheds Insulator

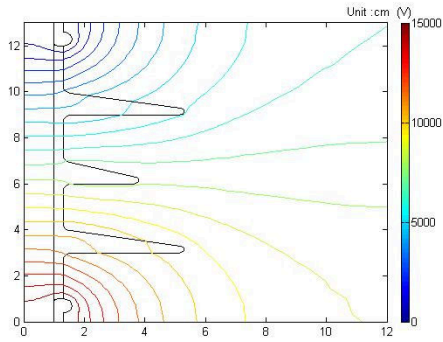

(b) Alternate Sheds Insulator

Fig. 7 Potential Distribution under Clean Condition

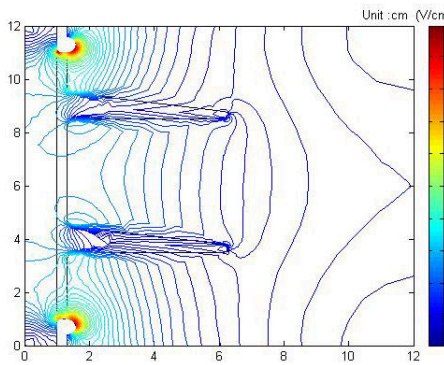

(a) Straight Sheds Insulator

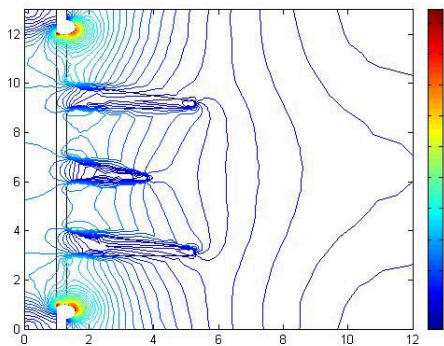

(b) Alternated Sheds Insulator

Fig. 8 Electric Field Distribution under Clean Condition

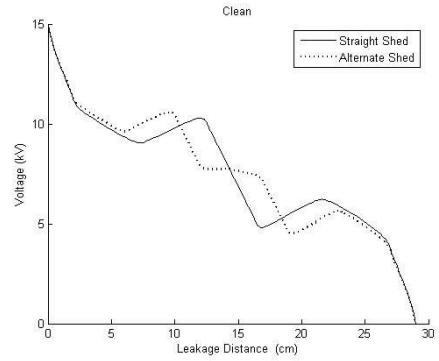

Fig. 9 Comparison of Potential Distribution

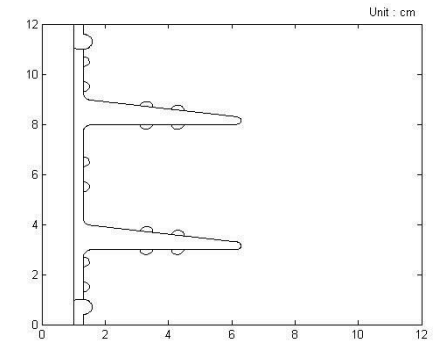
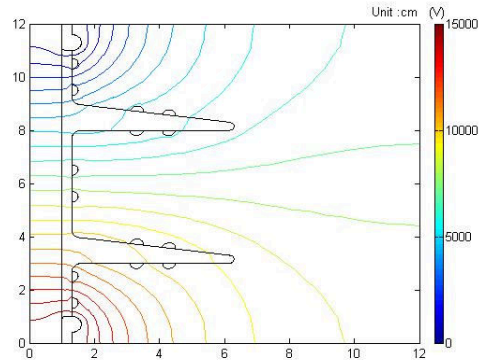
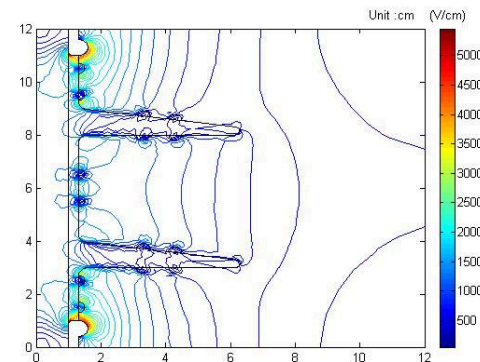

Fig. 10 Straight Sheds Insulator with Water Droplets on the Surface



(a) Potential Distribution



(b) Electric Field Distribution

Fig. 11 Straight sheds Insulator with Water Droplets on the Surface

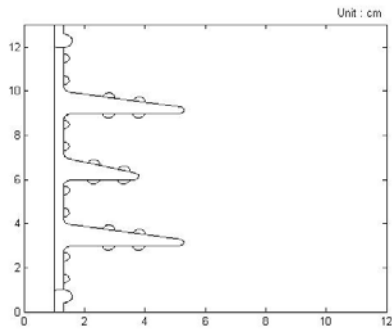
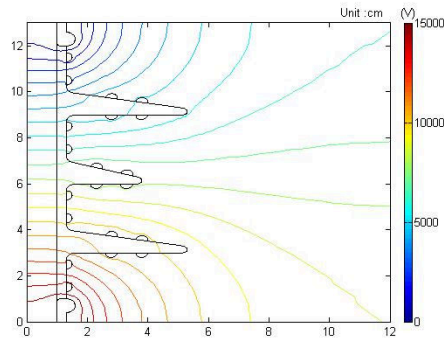
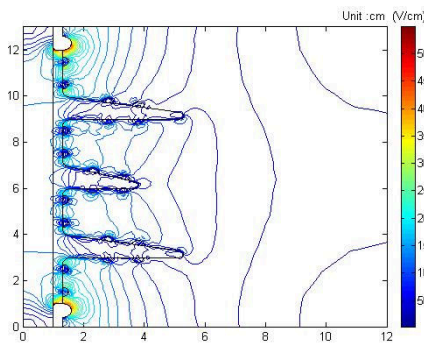

Fig. 12 Alternate Sheds Insulator with Water Droplets on the Surface



(a) Potential Distribution



(b) Electric Field Distribution

Fig. 13 Alternate Sheds Insulator with Water Droplets on the Surface

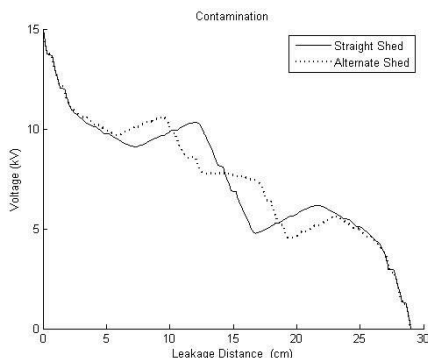

Fig. 14 Comparison of Potential Distribution under Contamination Condition

Comparison of potential distribution along leakage distance under contamination condition is illustrated in Fig. 14. Under

contamination condition, higher electric field distribution and more nonlinear potential distribution obtained from the straight sheds insulator comparing with the alternate sheds insulators. The simulation results are agreed with the experimental results. Higher magnitude of electric field caused more electric discharge on the insulator surface. More discharge activities caused severe surface damages.

V. CONCLUSION

Higher magnitude of electric field distribution and more nonlinear potential distributions on the straight sheds insulator comparing with the alternate shed insulators obtained from the simulation results by using Finite Element Method. The simulation results are agreed with the experimental results. In spite of the same leakage distance and the same material, different degree of surface aging obtained from polymer insulator having different configurations.

REFERENCES

- [1] CIGRE TF33.04.07, "Natural and Artificial Ageing and Pollution Testing of Polymer Insulators", CIGRE Pub. 142, June 1999.
- [2] G. G. Karady, H. M. Schneider and F. A. M. Rizk, "Review of CIGRE and IEEE Research into Pollution Performance of Non Ceramic Insulators: Field Ageing Effects and Laboratory Test Techniques", CIGRE 1994 Session Paper No. 33 – 103, August/September 1994.
- [3] I. Gutman, R. Harting, R. Matsuoka and K. Kondo, "Experience with IEC 1109 1000h Salt Fog Ageing Test for Composite Insulators", *IEEE Electrical Insulation Magazine*, Vol. 13, No. 3, May/June 1997, pp. 36 – 39.
- [4] T. Zhao and R. A. Bernstorf, "Ageing Tests of Polymeric Housing Materials for Non – ceramic Insulators", *IEEE Electrical Insulation Magazine*, Vol. 14, No. 2, March/April 1998, pp. 26 – 33.
- [5] R. S. Gorur, E. A. Cherney and R. Hackam, "A Comparative Study of Polymer Insulating Materials under Salt Fog Test", *IEEE Trans. on Electrical Insulation*, Vol. EI – 21, No. 2, April 1986, pp. 175 – 182.
- [6] M. C. Arklove and J. C. G. Wheeler, "Salt – Fog Testing of Composite Insulators", 7<sup>th</sup> *Int. Conf. on Dielectric Material, Measurements and Applications*, Conf. Pub. No. 430, September 1996, pp. 296 – 302.
- [7] S. H. Kim, R. Hackam, "Influence of Multiple Insulator Rods on Potential and Electric Field Distributions at Their Surface", *Int. Conf. on Electrical Insulation and Dielectric Phenomena 1994*, October 1994, pp. 663 – 668.
- [8] B. Marungsri, H. Shinokubo, R. Matsuoka and S. Kumagai, "Effect of Specimen Configuration on Deterioration of Silicone Rubber for Polymer Insulators in Salt Fog Ageing Test", *IEEE Trans. on DEI*, Vol. 13, No. 1, February 2006, pp. 129 – 138.
- [9] S. Sangkhasaad, "High Voltage Engineering", 3<sup>rd</sup> edition, Printed in Bangkok, Thailand, March 2006 (in Thai).
- [10] C. N. Kim, J. B. Jang, X. Y. Huang, P. K. Jiang and H. Kim, "Finite element analysis of electric field distribution in water treed XLPE cable insulation (1): The influence of geometrical configuration of water electrode for accelerated water treeing test", *J. of Polymer Testing*, Vol. 26, 2007, pp. 482 – 488.
- [11] P. Pao – la – or, "A New Design of Low Vibration Induction Motor using Finite Element Method", Doctoral Thesis, Suranaree University of Technology, Nakhon Ratchasima, Thailand, 2006.



**Boonruang Marungsri**, was born in Nakhon Ratchasima Province, Thailand, in 1973. He received his B. Eng. and M. Eng. from Chulalongkorn University, Thailand in 1996 and 1999 and D. Eng. from Chubu University, Kasugai, Aichi, Japan in 2006, all in electrical engineering, respectively. Dr. Marungsri is

currently a lecturer in School of Electrical Engineering, Suranaree University of Technology, Thailand. His areas of interest are electrical power system and high voltage insulation technologies.



**Winai Onchantuek** was born in Nakhon Ratchasima Province, Thailand in 1983. He received B. Eng. in Electrical Engineering from Suranaree University of Technology, Nakhon Ratchasima, Thailand in 2005. He has been teaching assistant in School of Electrical Engineering, Suranaree University of Technology for one year. Recently, he is graduate student in School of Electrical Engineering in the same university. His research interesting area are Finite Element Method and high voltage insulation technology.



**Anant Oonsivilai**, was born in Khon Kaen Province, Thailand, in 1963. He received his B. Eng. from Khon Kaen University, and M. Eng. from King Mongkut Institute of Technology North Bangkok, Thailand and PhD. from Dalhousie University, Canada, all in electrical Engineering, in 1986, 1992 and 2000, respectively. Dr. Oonsivilai is currently an Assistant Professor in School of Electrical Engineering, Suranaree University of Technology, Thailand. His areas of interest are electrical power system, stability, control technology, advance alternative, and sustainable energy.