

Dynamic Modeling and Simulation of Three-phase Small Power Induction Motor

Nyein Nyein Soe, Thet Thet Han Yee, and Soe Sandar Aung

Abstract—This paper is proposed the dynamic simulation of small power induction motor based on Mathematical modeling. The dynamic simulation is one of the key steps in the validation of the design process of the motor drive systems and it is needed for eliminating inadvertent design mistakes and the resulting error in the prototype construction and testing. This paper demonstrates the simulation of steady-state performance of induction motor by MATLAB Program Three phase 3 hp induction motor is modeled and simulated with SIMULINK model.

Keywords—Squirrel cage induction motor, modeling and simulation, MATLAB software, torque, speed.

I. INTRODUCTION

AN induction motor is simply an electric transformer whose magnetic circuit is separated by an air gap into two relatively movable portions, one carrying the primary and the other the secondary winding. Alternating current supplied to the primary winding from an electric power system induces an opposing current in the secondary winding, when the latter is short-circuited or closed through external impedance. Relative motion between the primary and secondary structure is produced by the electromagnetic forces corresponding to the power thus transferred across the air gap by induction.

The essential features which distinguish the induction machine from other type of electric motors is that the secondary currents are created solely by induction, as in a transformer instead of being supplied by a dc exciter or other external power sources, as in synchronous and dc machines.

The equivalent circuit of the induction motor is very similar to that for a transformer. Although the rotor currents are at slip frequency, the rotor is incorporated into the circuit in sample way. Three-phase induction motor is the most commonly used motor in industrial application for its simple design, reliable operation, rugged construction, low initial cost, easy operation and simple maintenance, high efficiency and having simple

control gear for starting and speed control. Induction motors are available with torque characteristics suitable for a wide variety of applications. Moreover, squirrel cage induction motors have more advantages than wound type. Squirrel cage induction motors have higher efficiency, less maintenances, better space factor in slots and lower cost. [1]

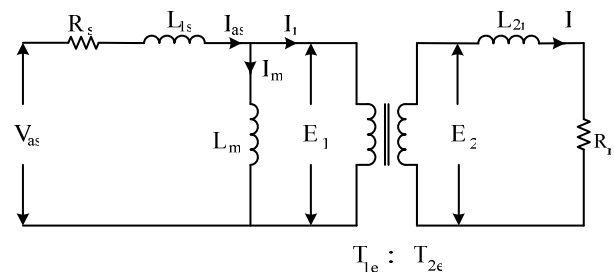

Fig. 1 Elementary equivalent circuit for induction motor

II. MEASUREMENT OF MOTOR PARAMETERS

A. Stator Resistance

With the rotor at standstill, the stator phase resistance is measured by applying a dc voltage and the resulting current. While this procedure gives only the dc resistance at a certain temperature, the ac resistance has to be calculated by considering the wire size, the stator frequency and the operating temperature.

B. No-load Test

The induction motor is driven at synchronous speed by another motor, preferably a dc motor. Then the stator is energized by applying rated voltage at rated frequency. The input power per phase is measured.

C. Locked-Rotor Test

The rotor of the induction motor is locked to keep it at standstill and a set of low three phase voltages is applied to calculate rated stator currents. The input power per phase is measured along with the input voltage and stator current. The slip is unity for the locked-rotor condition and hence the circuit resembles that of a secondary-shortened transformer. [2]

III. STEADY-STATE PERFORMANCE CALCULATION OF INDUCTION MOTOR

The required parameters for steady-state performance calculation of induction motor are received from laboratory

Nyein Nyein Soe is with the Electrical Power Engineering Department, Mandalay Technological University, Mandalay, Myanmar (corresponding author to provide phone: 095-067-22123; e-mail: nyeinnsoe@gmail.com, nyeintzaw@gmail.com).

Thet Thet Han Yee is with the Electrical Power Engineering Department, Mandalay Technological University, Mandalay, Myanmar (e-mail: thetthethanyee@gmail.com).

Soe Sandar Aung is with the Electrical Power Engineering Department, Mandalay Technological University, Mandalay, Myanmar (e-mail: soesandarag@gmail.com).

test results. Torque speed characteristic, power speed characteristic, efficiency speed characteristic of induction motor and magnitude of rotor and stator currents are shown in this paper.

TABLE I
INPUT PARAMETERS OF INDUCTION MOTOR

Symbol	Quantity	Input values
-	phase	3
p	Number of pole	4
f	frequency	50Hz
v_{ll}	Line to line voltage	380V
R_s	Stator resistance	3.5 Ω
R_r	Rotor resistance	3.16 Ω
R_c	Resistance to account for core losses	701 Ω
X_m	Magnetizing reactance	83.8 Ω
X_{ls}	Stator magnetizing leakage reactance	2.17 Ω
X_{lr}	Rotor magnetizing leakage reactance	2.14 Ω

A. Torque Speed Characteristic of Induction Motor

$$\text{Full load torque, } T_f = \frac{k_s R_r E_r^2}{R_r^2 + s^2 X_r^2} \tag{1}$$

$$\text{Maximum torque, } T_m = \frac{kE_2^2}{2X_r} \tag{2}$$

where, s= full load slip of motor

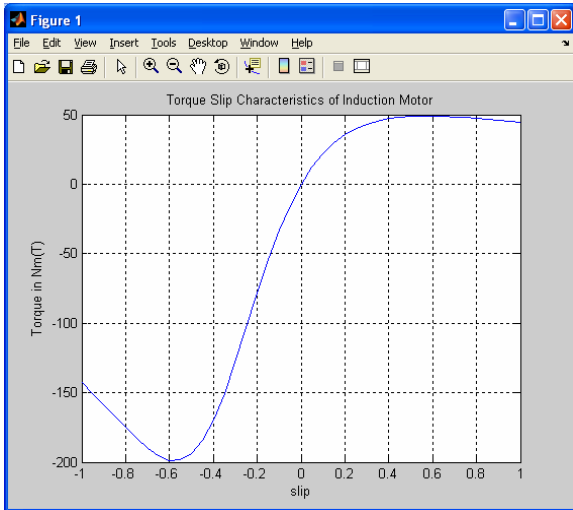

Fig. 2 Torque slip characteristic of induction motor

B. Power Speed Characteristic of Induction Motor

$$\text{Power} = \omega_m T \tag{3}$$

$$\text{where, rotor speed } \omega_m = \frac{\omega_r}{p/2} = \frac{\omega_s(1-s)}{p/2} \tag{4}$$

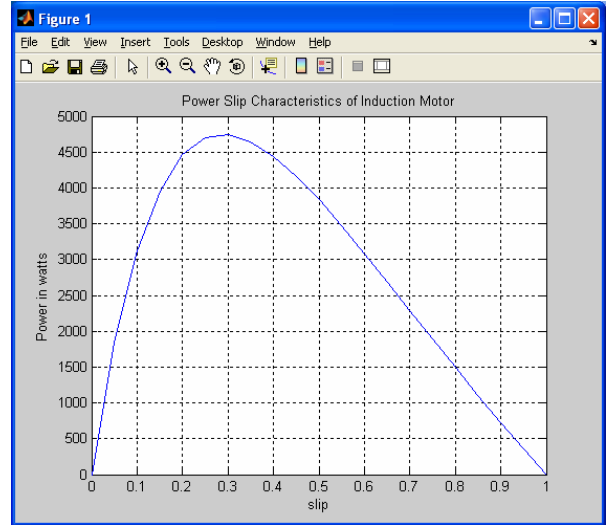

Fig. 3 Power slip characteristic of induction motor

C. Magnitude of Stator Current in Induction Motor

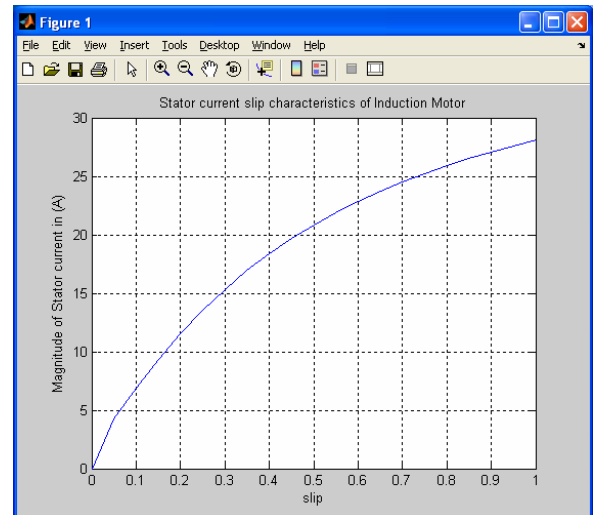

Fig. 4 Stator Current Vs slip characteristic of induction motor

D. Efficiency of Induction Motor

In an induction motor, copper losses, core losses and friction and windage losses are occurred. There are copper losses and core losses in the stator, and copper losses and frictional losses in the rotor. Actually there is some core losses in the rotor. Under operating conditions, however, the rotor frequency is so low that it may logically be assumed that all core losses occur in the stator only. The efficiency of induction motor can be determined by loading the motor and measuring the input and output directly.

$$\eta = P_{\text{output}}/P_{\text{input}} \tag{5}$$

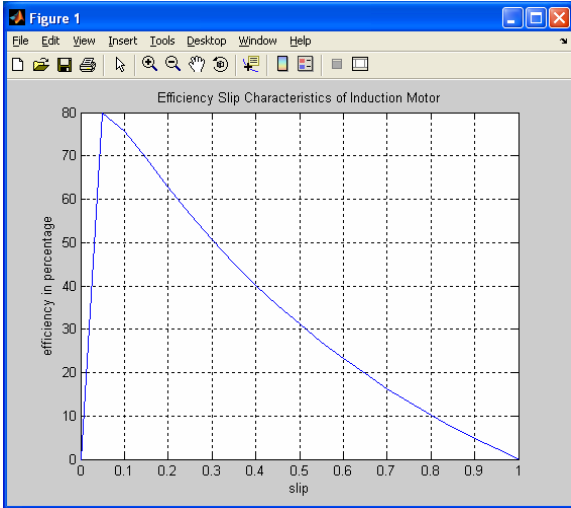

Fig. 5 Efficiency speed characteristic of induction motor

E. Magnitude of Rotor Current in Induction Motor

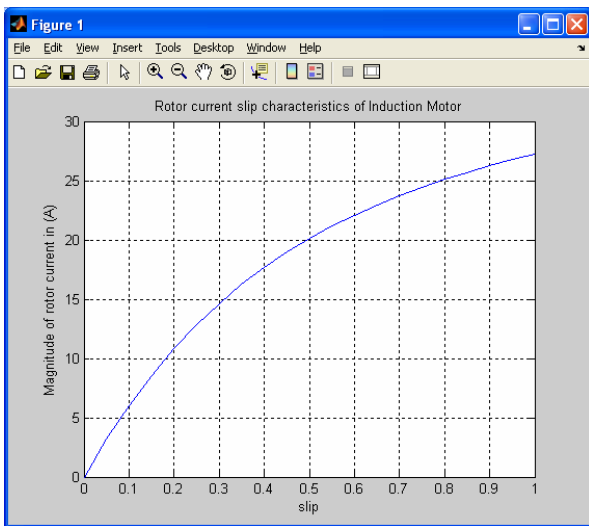

Fig. 6 Rotor Current Vs speed characteristic of induction motor

IV. COMPUTATION OF STEADY-STATE PERFORMANCE OF INDUCTION MOTOR

The slip is chosen in place of rotor speed because it is nondimensional and so it is applicable to any motor frequency. Near the synchronous speed, at low slips, the torque is linear and is proportional to slip; beyond the maximum torque, the torque is approximately inversely proportional to slip. [3]

A flow chart for the evaluation of the steady-state performance of the motor is shown in Fig. 7. The torque Vs slip characteristics are shown from point -1 to 1.

The maximum torque for induction motor is 0.2 slip position as shown in Fig. 2. The lowest value of torque is occurred at -0.2 slip point.

V. DYNAMIC SIMULATION OF THREE-PHASE INDUCTION MOTOR

The dynamic model of induction machine is built by SIMULINK model. Torque, speed, stator and rotor current are obtained from this model.

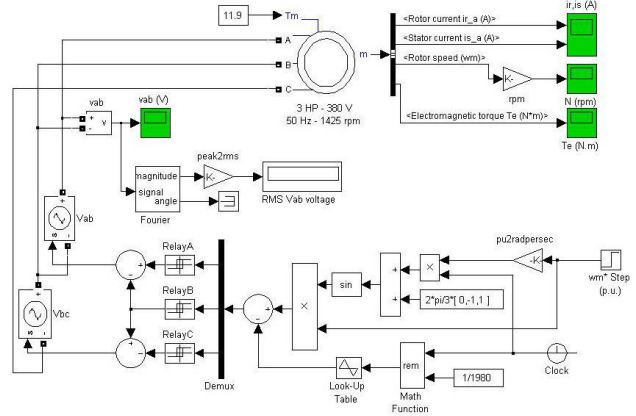

Fig.7 The SIMULINK block diagram of three-phase induction motor

TABLE II
BLOCK PARAMETERS OF INDUCTION MOTOR

Required Parameter	values
phase	3
Number of pole	4
frequency	50Hz
Line to line voltage	380V
Stator resistance	3.5 Ω
Rotor resistance	3.16Ω
Resistance to account for core losses	701 Ω
Mutual inductance	0.26674H
Stator magnetizing leakage inductance	6.90732mH
Rotor magnetizing leakage inductance	6.81183mH

A three-phase motor rated 3 hp, 380 V, 1425 rpm is fed by a sinusoidal PWM inverter. The base frequency of the sinusoidal reference wave is 50 Hz. The PWM inverter is built entirely with standard Simulink blocks. Its output goes through Controlled Voltage Source blocks before being applied to the Asynchronous Machine block's stator windings. The machine's rotor is short-circuited. Its stator leakage inductance L_{ls} is set to twice its actual value to simulate the effect of a smoothing reactor placed between the inverter and the machine. The load torque applied to the machine's shaft is constant and set to its nominal value of 11.9 N.m.

The motor is started from stall. The speed setpoint is set to 1.0 pu, or 1425 rpm. This speed is reached after 0.8 s.

The noise introduced by the PWM inverter is also observed in the electromagnetic torque waveform T_e . However, the

motor's inertia prevents this noise from appearing in the motor's speed waveform.

VI. ROTOR SPEED OF AN INDUCTION MOTOR

Fig. 8 shows the rotor-speed curve of three-phase induction motor (wound rotor type). With respect to the above figure, the rotor speed is gradually increased to the rated speed. The rated speed is 1425 rpm and it is reached at nearly 0.8 second.

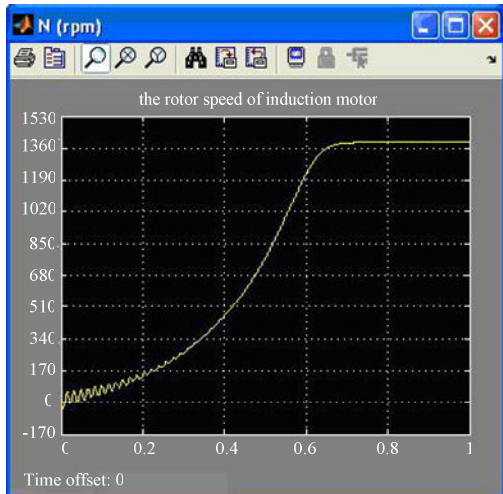

Fig. 8 Rotor speed of three-phase induction motor

VII. STATOR AND ROTOR CURRENT RESPONSE OF THREE-PHASE INDUCTION MOTOR

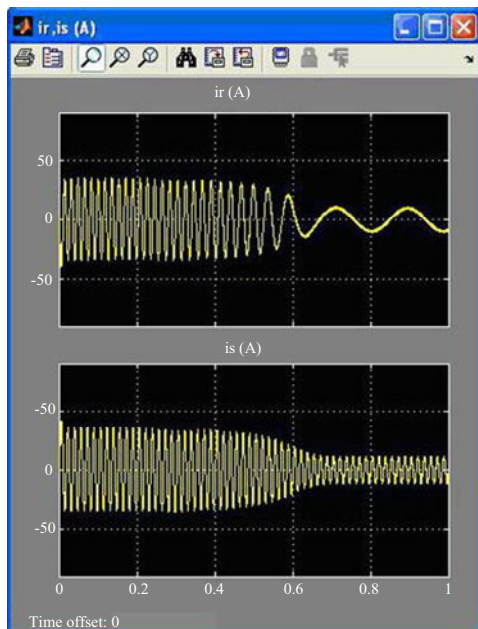

Fig. 9 Stator and Rotor current of three-phase induction motor

The stator and rotor current response of three-phase induction motor is described in Fig. 9. The rotor current

fluctuates between 0 and 0.6 second. The stator current is drawn about 10 A at 0.8 second as shown in this figure.

VIII. TIME RESPONSE OF ELECTROMAGNETIC TORQUE IN THREE-PHASE INDUCTION MOTOR

In Fig. 10, the time response of electromagnetic torque of three-phase induction motor is expressed. The electromagnetic torque of three-phase induction motor is firstly variable in 0 to 0.4 second. Then the rated torque is reached at 0.8 second. The rated torque can be seen 11.9 N.m as shown in Fig. 10.

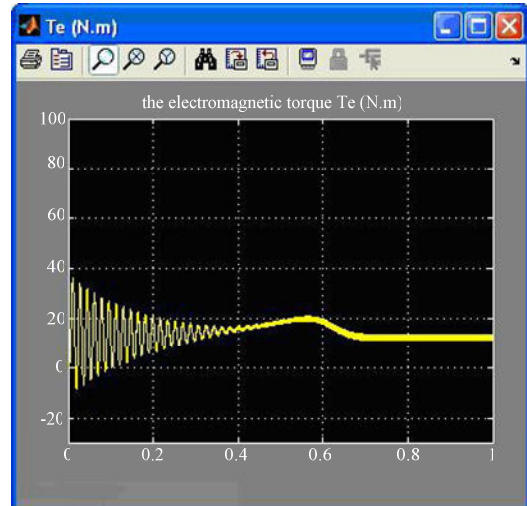

Fig. 10 Time Response of electromagnetic torque of induction motor

ACKNOWLEDGMENT

I would like to thank first and foremost my teacher Dr. Hla Myo Aung, for his patience, care and guidance given to me throughout the duration of my field study. Then, I would like to dedicate this to my parents who support everything to me. Lastly, I would like to think all teachers who give their tremendous moral supports during my study.

REFERENCES

- [1] R.K.Rajput, "Electrical Machines," first edition, New York: McGraw-Hill, 1993, pp. 352-353
- [2] R.Krishnan, "Electric Motor Drives Modeling, Analysis and Control", first edition, 2001 Prentice-Hall International, Inc. Upper Saddle River, New Jersey 07458.
- [3] Stephen D.Umans, " Electric Machinery", fourth edition, McGrew-Hill Series in Electrical Engineering.

Nyein Nyein Soe studied in Electrical Power Engineering major and held B.E degree in 2004 from Mandalay Technological University, Mandalay, Myanmar. Then I was awarded M.E degree of Electrical Power Engineering in 2006 from Yangon Technological University, Yangon, Myanmar. Now I am studying modeling and simulation program in Mandalay Technological University.