

A MATLAB Simulink Library for Transient Flow Simulation of Gas Networks

M. Behbahani-Nejad, and A. Bagheri

Abstract—An efficient transient flow simulation for gas pipelines and networks is presented. The proposed transient flow simulation is based on the transfer function models and MATLAB-Simulink. The equivalent transfer functions of the nonlinear governing equations are derived for different types of the boundary conditions. Next, a MATLAB-Simulink library is developed and proposed considering any boundary condition type. To verify the accuracy and the computational efficiency of the proposed simulation, the results obtained are compared with those of the conventional finite difference schemes (such as TVD, method of lines, and other finite difference implicit and explicit schemes). The effects of the flow inertia and the pipeline inclination are incorporated in this simulation. It is shown that the proposed simulation has a sufficient accuracy and it is computationally more efficient than the other methods.

Keywords—Gas network, MATLAB-Simulink, transfer functions, transient flow.

I. INTRODUCTION

NATURAL gas transportation and distribution are commonly accomplished in many countries through the gas pipelines and networks. Due to the on-line networks controlling and reasons that are incidental or/and accidental to the operation of gas transmission pipelines or networks, transient flows do commonly arise. Thus, pipeline operations are actually transient processes and in fact steady state operations are rarity in practice. The governing equations for a transient subsonic flow analysis of natural gas in pipelines are a set of two nonlinear hyperbolic partial differential equations. Many algorithms and numerical methods such as implicit and explicit finite differences, method of characteristics and so on, have been applied by several researchers for transient flow in gas pipelines [1]–[6], but unfortunately, almost all of these conventional schemes are time consuming especially for gas network analysis.

Some of investigators [1], [2] have neglected inertia term in momentum equation to linearize partial differential set of equations. However, it will result in loss of accuracy. Yow

introduced the concept of inertia multiplier to partially account the effect of the inertia term [3]. Osiadacz et al. simulated transient gas flow with isothermal assumption without neglecting any terms in momentum equation for gas networks [4]. Kiuchi used an implicit method to analyze unsteady gas networks at isothermal conditions [6]. Also, Dukhovnaya and A. Michael [7], and Zhou and Adewumi [8] did flow simulation with the same assumptions and using TVD schemes. Tentis et al. have used an adaptive method of lines to simulate the transient gas flow in pipelines [9]. Ke and Ti analyzed isothermal transient gas flow in the pipeline networks using the electrical models for the loops and nodes [10]. Recently and in a new work, Gonzales et al. [11] have used MATLAB-Simulink and prepared some S-functions to simulate transient flow in gas networks. At their work, two simplified models have derived containing Crank-Nicolson algorithm and method of characteristics.

Reddy et al. [12] have proposed an efficient transient flow simulation for gas pipelines and networks using the transfer functions in Laplace domain. They derived the equivalent transfer functions for the governing equations and then, using the convolution theorem, they obtained the series form of the output in the time domain. In the present study the transient flow transfer functions are employed with another efficient approach. The object of this paper is to prepare a MATLAB-Simulink library in order to simulate the transient flow in gas pipelines and networks. For this purpose, the transfer functions of a single pipeline are derived and applied to develop a MATLAB-Simulink library. Next, this library is used for a gas pipeline transient flow simulation and its accuracy and efficiency is compared with those results obtained by an accurate implicit nonlinear finite difference scheme. The idea is then extended for a typical network simulation. The results obtained show that proposed simulation has a sufficient accuracy and is more efficient than the other methods.

II. MATHEMATICAL MODEL

The set of partial differential equations describing the general one-dimensional compressible gas flow dynamics through a pipeline under isothermal conditions is obtained by applying the conservation of mass, momentum and an equation of state relating the pressure, density and the temperature. For a general pipe as shown in Fig. 1, these hyperbolic partial differential equations are [13]

Manuscript received July 4, 2008. This work was supported in part by the Khuzestan Gas Company and Shahid Chamran University.

M. Behbahani-Nejad, Assistant Professor, is with the Mechanical Engineering Department, Shahid Chamran University, Ahvaz, Iran (corresponding author to provide phone: (+98) 611-333-0011; fax: 611-333-5398; e-mail: bnmorteza@scu.ac.ir).

A. Bagheri is with the Mechanical Engineering Department, Shahid Chamran University, Ahvaz, Iran (e-mail: alibaqeri_j_a@yahoo.com).

$$\frac{\partial \rho}{\partial t} + \frac{\partial(\rho u)}{\partial x} = 0 \quad (1)$$

$$\frac{\partial(\rho u)}{\partial t} + \frac{\partial(\rho u^2 + P)}{\partial x} = -\frac{\rho u|u|}{2D}f - \rho g \sin \alpha \quad (2)$$

$$P = \rho Z R_g T \quad (3)$$

where ρ is the gas density, P is the pressure, u is the gas axial velocity, g is the gravitational acceleration, α is the pipe inclination, f is the friction coefficient, Z is the gas compressibility factor, and D is the pipeline diameter.

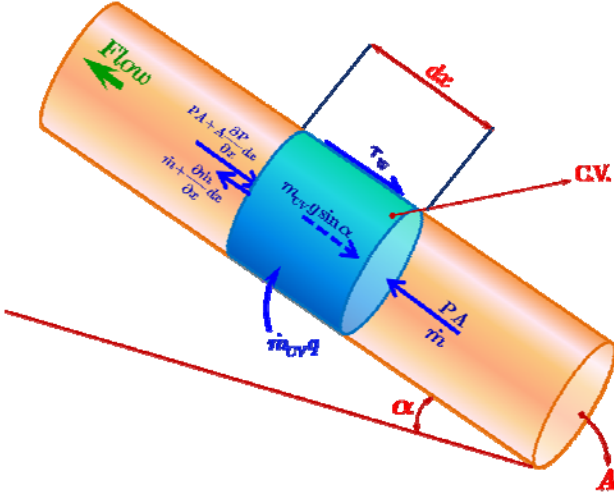

Fig. 1 A control volume in a general gas pipeline

The governing equations in matrix form are

$$\frac{\partial \mathbf{U}}{\partial t} + \frac{\partial \mathbf{F}}{\partial x} = \mathbf{R} \quad (4)$$

where

$$\mathbf{F} = \begin{bmatrix} \rho u \\ \rho u^2 + P \end{bmatrix}, \quad \mathbf{R} = \begin{bmatrix} 0 \\ -\frac{\rho u|u|}{2D}f - \rho g \sin \alpha \end{bmatrix} \quad (5)$$

Another form of the relations (1) and (2) versus the gas pressure and the mass flow rate can be written as [13]

$$\frac{\partial}{\partial t} \left(\frac{P}{(1 + \hat{k}P)RT} \right) + \frac{1}{A} \frac{\partial \dot{m}}{\partial x} = 0 \quad (6)$$

$$\frac{\partial P}{\partial x} = -\frac{1}{A} \frac{\partial \dot{m}}{\partial t} - RT \frac{\partial}{\partial x} \left(\frac{1 + \hat{k}P}{A^2 P} \dot{m}^2 \right) - \frac{f}{2DA^2} \frac{|\dot{m}| \dot{m}}{P} (1 + \hat{k}P) RT - g \frac{\Delta h}{L} \frac{P}{(1 + \hat{k}P)RT} \quad (7)$$

where \dot{m} shows the mass flow rate and \hat{k} is an experimental parameter which is used to compute the compressibility factor, i.e.

$$Z = 1 + \hat{k}P \quad (8)$$

III. FINITE DIFFERENCE SCHEME

The implicit Steger-Warming flux vector splitting method (FSM) in delta formulation has been used as the numerical scheme. This method is chosen, because it doesn't have the problem of numerical instability [14]. The finite difference form of the governing equations is

$$\begin{aligned} -\frac{\Delta t}{\Delta x} \mathbf{A}_{i-1}^+ \Delta \mathbf{U}_{i-1} + \left\{ \mathbf{I} + \frac{\Delta t}{\Delta x} (\mathbf{A}_i^+ - \mathbf{A}_i^-) - \Delta t \mathbf{B}_i \right\} \Delta \mathbf{U}_i \\ + \frac{\Delta t}{\Delta x} \mathbf{A}_{i+1}^- \Delta \mathbf{U}_{i+1} = \\ -\frac{\Delta t}{\Delta x} \left\{ (\mathbf{F}_i^+ - \mathbf{F}_{i-1}^+) + (\mathbf{F}_{i+1}^- - \mathbf{F}_i^-) \right\} + \Delta t \mathbf{R}_i \end{aligned} \quad (9)$$

where

$$\Delta \mathbf{U} = \mathbf{U}^{n+1} - \mathbf{U}^n \quad (10)$$

and subscript i indicates the spatial grid point, superscript n indicates the time level, and moreover

$$\begin{aligned} \mathbf{A}^+ &= \begin{bmatrix} \frac{c^2 - u^2}{2c} & \frac{u + c}{2c} \\ \frac{(u + c)^2 (c - u)}{2c} & \frac{(u + c)^2}{2c} \end{bmatrix}, \\ \mathbf{A}^- &= \begin{bmatrix} \frac{u^2 - c^2}{2c} & \frac{c - u}{2c} \\ \frac{(u + c)(c - u)^2}{2c} & -\frac{(c - u)^2}{2c} \end{bmatrix} \\ \mathbf{F}^+ &= \begin{bmatrix} \frac{\rho(u + c)}{2} \\ \frac{\rho(u + c)^2}{2} \end{bmatrix}, \quad \mathbf{F}^- = \begin{bmatrix} \frac{\rho(u - c)}{2} \\ \frac{\rho(u - c)^2}{2} \end{bmatrix} \end{aligned} \quad (11)$$

where c is the speed of acoustic wave in the gas flow. When (9) is applied to each grid point, a block tridiagonal system of algebraic equations will be obtained. This equations system can be solved at each time step using Thomas algorithm, which results in $\Delta \mathbf{U}$. Next, \mathbf{U} at the advanced time level can be calculated using (10).

IV. FLOW TRANSFER FUNCTIONS

To obtain the flow transfer functions, P_0 , T_0 , A_0 , and ρ_0 are considered as the reference values and the nonlinear partial differential equations (6) and (7) are linearized about them. Moreover, these reference values are also considered to define the corresponding dimensionless variables expressed as

$$\begin{aligned} \xi &= \frac{x}{L} \\ t^* &= \frac{tc}{L} \\ P^* &= \rho^* = \frac{P}{P_0} \end{aligned} \quad (12)$$

$$\dot{m}^* = \dot{m}c / P_0 A_0$$

$$u^* = \frac{u_0}{c}$$

where u_0 is the average gas velocity in the pipe and is calculated as [13]

$$u_0 = \frac{(\dot{m}_{in} + \dot{m}_{out})Z_0RT_0}{(P_{in} + P_{out})A_0} \quad (13)$$

When the governing equations (6) and (7) are linearized and the nondimensional variables are used, with some mathematical manipulations one obtains [13]

$$\frac{\partial \Delta \dot{m}^*}{\partial \xi} = -\frac{\partial \Delta P^*}{\partial t^*} \quad (14)$$

$$\left[1 - u^{*2}\right] \frac{\partial \Delta P^*}{\partial \xi} = -\frac{\partial \Delta \dot{m}^*}{\partial t^*} + 2u^* \frac{\partial \Delta P^*}{\partial t^*} - \left[u^* \left|fL^* \Delta \dot{m}^* + \left\{\frac{fL^*}{2} u^* |u^*| - \frac{g\Delta h}{c^2}\right\} \Delta P^*\right.\right] \quad (15)$$

where

$$\Delta P^* = P^* - P_o^* \quad (16)$$

$$\Delta \dot{m}^* = \dot{m}^* - \dot{m}_o^*$$

Since for the practical subsonic transient flows $u^* = u_0/c \ll 1$, one can omit u^{*2} at the left hand side of (15). Taking the Laplace transform of (14) and (15), yields the following two coupled linear ordinary differential equations

$$\frac{\partial \Delta \dot{m}^*(s)}{\partial \xi} = -s \Delta P^*(s) \quad (17)$$

$$\frac{\partial \Delta P^*(s)}{\partial \xi} = -\left[u^* \left|fL^* + s\right| \Delta \dot{m}^*(s) + \left\{\frac{fL^*}{2} u^* |u^*| - \frac{g\Delta h}{c^2} + 2u^* s\right\} \Delta P^*(s)\right] \quad (18)$$

After imposing the boundary conditions, the above system of ODE can be solved. For example, if the gas pressure at the inlet and the mass flow rate at the pipe outlet are specified as functions of time, the above system of ODE results in

$$\begin{cases} \Delta P_{out}^*(s) = e^{\gamma/2} \frac{2b}{2b \cosh(b) - \gamma \sinh(b)} \Delta P_{in}^*(s) + \\ \quad - \frac{2\alpha \sinh(b)}{2b \cosh(b) - \gamma \sinh(b)} \Delta M_{out}^*(s) \\ \Delta M_{in}^*(s) = \frac{2\beta \sinh(b)}{2b \cosh(b) - \gamma \sinh(b)} \Delta P_{in}^*(s) + \\ \quad + e^{-\gamma/2} \frac{2b}{2b \cosh(b) - \gamma \sinh(b)} \Delta M_{out}^*(s) \end{cases} \quad (19)$$

where α , β , b and γ are defined in appendix A. After Taylor-expansion of the hyperbolic terms in (19), the simplified transfer functions are

$$\begin{cases} \Delta P_{out}^*(s) = F_{P_{out},P_{in}} \Delta P_{in}^*(s) + F_{M_{out},P_{out}} \Delta M_{out}^*(s) \\ \Delta M_{in}^*(s) = F_{M_{in},P_{in}} \Delta P_{in}^*(s) + F_{M_{in},M_{out}} \Delta M_{out}^*(s) \end{cases} \quad (20)$$

where

$$F_{P_{out},P_{in}}(s) = k_1 \frac{1}{1 + a_1 s + a_2 s^2} \quad (21)$$

$$F_{M_{in},P_{in}}(s) = \frac{c_1 s + c_2 s^2}{1 + \hat{a}_1 s + \hat{a}_2 s^2} \quad (22)$$

$$F_{P_{out},M_{out}}(s) = k_2 \frac{1 + b_1 s + b_2 s^2}{1 + \hat{a}_1 s + \hat{a}_2 s^2} \quad (23)$$

$$F_{M_{in},M_{out}}(s) = \frac{1}{1 + d_1 s + d_2 s^2} \quad (24)$$

The coefficients of the above expansions are also presented in appendix A. For other types of the boundary conditions, similar relations can be obtained.

V. MATLAB SIMULINK MODEL

When the flow transfer functions are obtained, they can be used to make a MATLAB-Simulink model for transient analysis. Fig. 2 shows a Simulink model for a single pipe when the gas pressure at the inlet and the mass flow rate at the outlet are known. For other boundary conditions, similar models can be made.

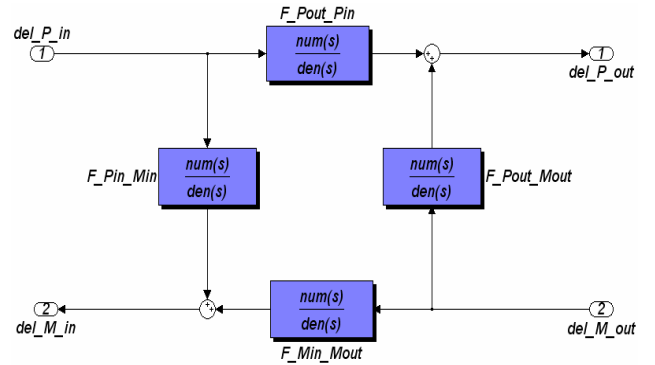

Fig. 2 A simulink model when the pipeline inlet pressure and the outlet gas flow rate are known

At the present work, a Simulink library for each type of the boundary conditions is made in the MATLAB-Simulink browser that is called as shown in Fig. 3. In this library each block has two inputs which are known from the boundary conditions, and two outputs as the results of the transient simulation. Then, the proposed approach is extended to simulate a gas network. A typical network which has been studied by Ke and Ti [10] is considered and simulated with the proposed approach. Fig. 4 shows a schematic of this network and its Simulink model is illustrated in Fig. 5. The accuracy of the obtained results and the computational efficiency of the proposed simulation are discussed in the next section.

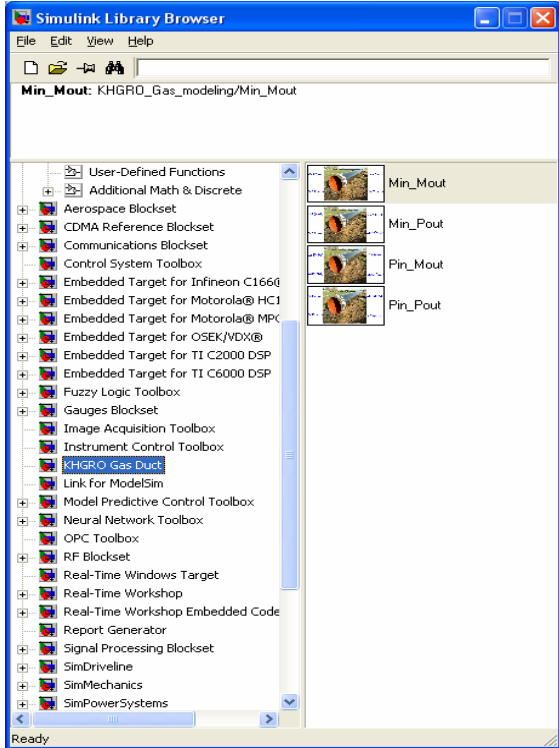

Fig. 3 The present MATLAB-Simulink

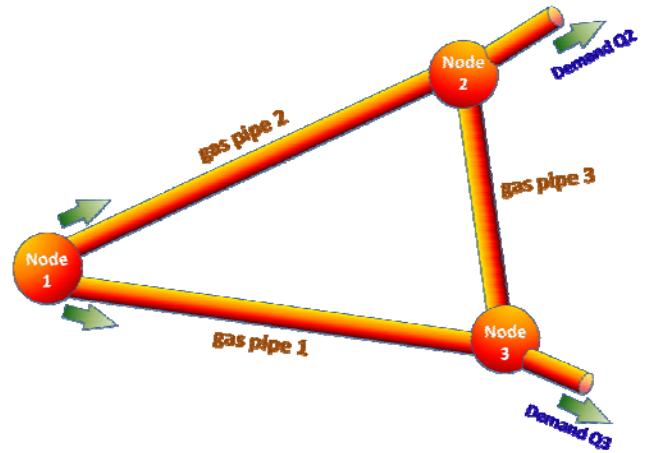

Fig. 4 The gas pipeline network

The pipeline transports natural gas of 0.675 specific gravity at 10°C. The gas viscosity is 1.1831×10^{-5} N.sec/m², while the pipeline wall roughness is 0.617 mm and isothermal sound speed equals 367.9 m/s. At the pipeline's inlet, the gas pressure is kept constant at 4.205 MPa, whereas the pipe's mass flow rate at the outlet varies with a 24-hour cycle, corresponding to changes in consumer demand within a day as is depicted in Fig. 6.

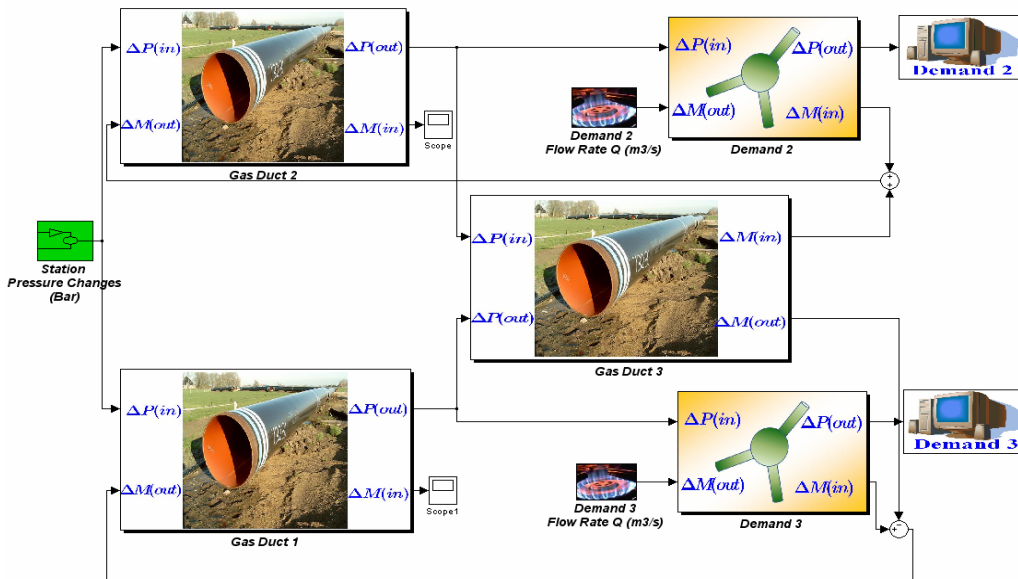

Fig. 5 Simulink model of the gas pipeline network

VI. RESULTS AND DISCUSSIONS

The results of the proposed transient simulation are compared with those of the implicit FSM as an accurate nonlinear finite difference scheme. In order to verify the accuracy of the present implicit FSM, a 72259.5 m long pipeline of 0.2 m diameter was considered as a test case. The test case which its experimental results are available, has been studied by Taylor et al. [15], Zhou and Adewumi [8], and also by Tentis et al. [9].

Fig. 7 illustrates the present results of FSM for pressure time changes at the pipe outlet, along with those of the others [8], [9], [15] and the experiments. There are some differences between the present nonlinear FSM results with those obtained by the others. However, when they are compared with the experiments, it seems that all of the numerical methods have the nearly similar differences with experiments. The interesting point is the accuracy of the results of the proposed transfer function model. As it is seen in Fig. 7, the

present transfer function model can predict the transient behavior of the outlet pressure as nearly accurate as the nonlinear finite difference models.

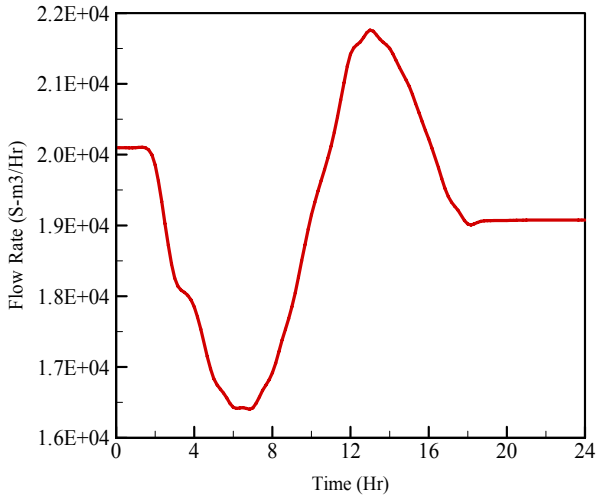

Fig. 6 A 24-hour irregular flow imposed at the pipe outlet

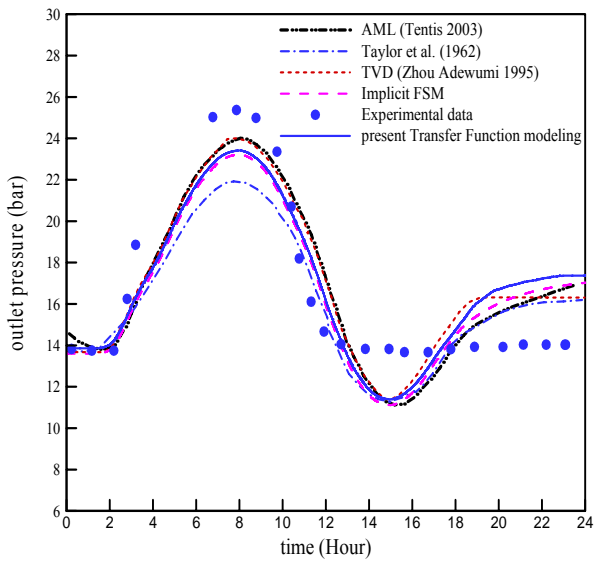

Fig. 7 Comparison of pressure time history at the outlet

A harmonic demand as shown in Fig. 8 was imposed at the pipe outlet as another test case. From Fig. 9, it is observed that the present transfer function model can well follow the results of the implicit FSM after a few minutes. The relatively large errors at the initial times are expected because at these times the outlet pressure does not achieve its purely harmonic behavior.

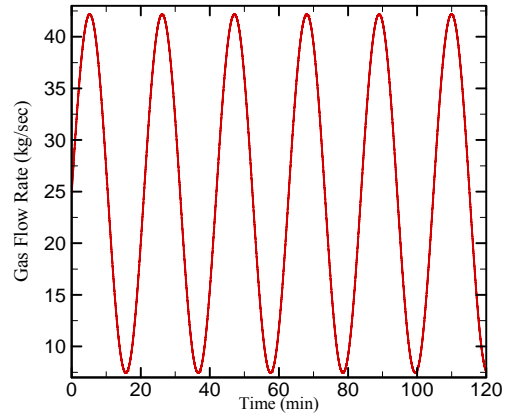

Fig. 8 A periodic demand imposed at the pipe outlet

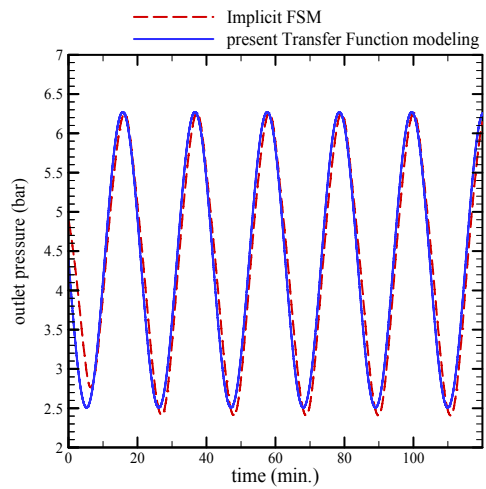

Fig. 9 The gas outlet pressure predicted by the present simulation and implicit FSM

Finally, a typical network as shown in Fig. 4 was considered to confirm the results of the present gas network simulation. The geometrical data of the network is introduced in Table I and the gas demand at the nodes 2 and 3 are illustrated in Fig. 10. The pressure source in the network is node 1 which is maintained at a constant pressure of 50 bar. The gas specific gravity is approximately 0.6, the operational temperature is 278 K, and the friction factor is considered to be constant and equal to 0.003. The present simulation results are compared with those obtained by Ke and Ti [10] in Figs. 11 and 12. As is shown in the figures a good agreement is observed although some differences exist at the sharp points. This behavior implies that the transfer function model results in the sharp changes in the outlet pressure if the demand at the outlet is sharp.

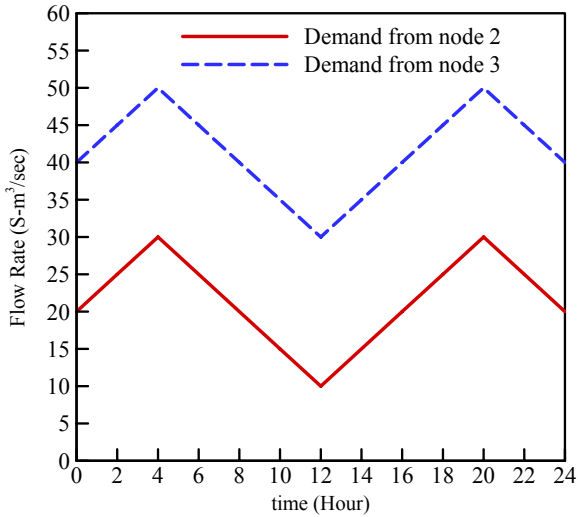

Fig. 10 Demands versus time for nodes 2 and 3 of the simulated network

TABLE I
PIPE GEOMETRICAL DATA FOR THE RELATED NETWORK

Gas Duct ID	From node	To node	Diameter (m)	Length (km)
1	1	3	0.6	80
2	1	2	0.6	90
3	2	3	0.6	100

The computational efficiency of the proposed simulation is compared with the implicit FSM through the results presented in Table II. It is observed that the proposed simulation is extremely efficient than the conventional finite difference methods.

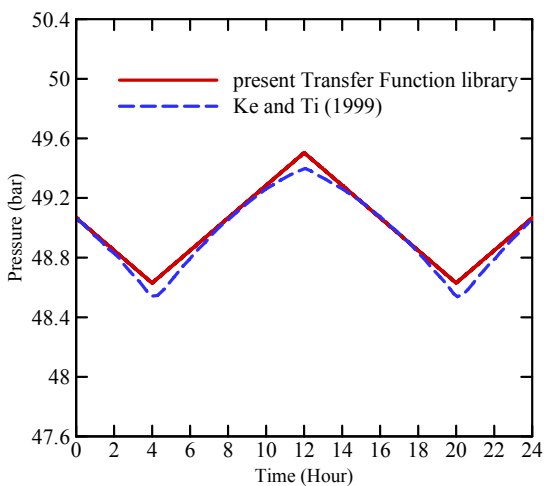

Fig. 11 Outlet pressure results for nodes 2

TABLE I
SPEED COMPARISON BETWEEN USED METHODS

method	CPU time (s)
transfer function (current study)	1.18
implicit method	34.52

VII. CONCLUSION

The proposed simulation can be applied to analyze the transient flow of natural gas in pipelines and networks with a sufficient accuracy. Since the proposed simulation is used the transfer functions of the transient gas flows, it is more computationally efficient than the other finite difference methods. On the other hand, it is an easy task to analyze the transient flows with any boundary condition types using the proposed MATLAB-Simulink library. Moreover, one can assemble the transfer functions of all the network pipes to simulate the dynamic behavior of a gas network. The present study is shown that the proposed simulation extremely reduces the computational time comparing the other numerical schemes. However, because the present simulation is based on the flow transfer functions it only gives the endpoints results and not those distributions along the pipelines.

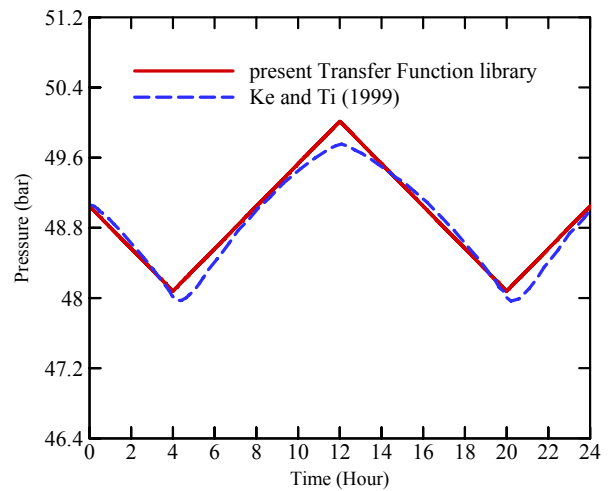

Fig. 12 Outlet pressure results for nodes 3

APPENDIX A

In this appendix, the algebraic expressions of the parameters used in (19) and (21)-(24) are presented. α , β , γ and b which are used in (19) are stated as [13]

$$\begin{aligned} \alpha(s) &= \alpha_1 + \alpha_2 s \\ \beta(s) &= \beta_1 s \\ \gamma(s) &= \gamma_1 + \gamma_2 s \\ b(s) &= \sqrt{\gamma^2 + 4\alpha\beta} / 2 \end{aligned} \tag{A-1}$$

where

$$\begin{aligned} \alpha_1 &= |u^*| fL^*, \quad \alpha_2 = L/c, \quad \beta_1 = L/c, \\ \gamma_1 &= \frac{fL^*}{2} u^* |u^*| - \frac{g\Delta h}{c^2}, \quad \gamma_2 = 2u^* L/c \end{aligned} \tag{A-2}$$

The other parameters which have been used in (21)-(24) are [16]

$$\hat{a}_1 = e^{\frac{\gamma_1}{2}} \left[\frac{1}{2} \alpha_1 \beta_1 \left(1 - \frac{1}{6} \gamma_1 + \frac{1}{24} \gamma_1^2 - \frac{1}{240} \gamma_1^3 + \dots \right) \right] - \frac{\gamma_2}{2} \tag{A-3}$$

$$\begin{aligned} \hat{a}_2 &= e^{\frac{\gamma_1}{2}} \left[\frac{1}{24} \alpha_1^2 \beta_1^2 \left(1 - \frac{1}{10} \gamma_1 \right) + \right. \\ &\quad \left. \frac{1}{2} \alpha_2 \beta_1 \left(1 - \frac{1}{6} \gamma_1 + \frac{1}{24} \gamma_1^2 + - \frac{1}{240} \gamma_1^3 + \dots \right) - \right. \\ &\quad \left. \frac{1}{12} \alpha_1 \beta_1 \gamma_2 \left(1 - \frac{1}{2} \gamma_1 - \frac{1}{16} \gamma_1^2 - \dots \right) \right] + \frac{1}{8} \gamma_2^2 \end{aligned} \tag{A-4}$$

$$k_1 = e^{\gamma_1} \tag{A-5}$$

$$a_1 = \hat{a}_1 - \frac{1}{2} \gamma_2 \tag{A-6}$$

$$a_2 = \hat{a}_2 + \frac{1}{8} \gamma_2^2 - \frac{1}{2} \gamma_2 \hat{a}_1 \tag{A-7}$$

$$k_2 = e^{\frac{\gamma_1}{2}} \alpha_1 \left(1 + \frac{1}{24} \gamma_1^2 + \frac{1}{1920} \gamma_1^4 \right) \tag{A-8}$$

$$b_1 = \frac{\alpha_2}{\alpha_1} + \frac{\left(\alpha_1 \beta_1 + \frac{1}{12} \gamma_1 \gamma_2 \right) \left(1 + \frac{1}{40} \gamma_1^2 \right)}{1 + \frac{1}{4} \gamma_1^2 + \frac{1}{320} \gamma_1^4} \tag{A-9}$$

$$\begin{aligned} b_2 &= \frac{1}{1 + \frac{1}{24} \gamma_1^2 + \frac{1}{1920} \gamma_1^4} \times \\ &\quad \left\{ \frac{\alpha_2}{\alpha_1} \left(\frac{1}{6} \alpha_1 \beta_1 + \frac{1}{12} \gamma_1 \gamma_2 \right) \left(1 + \frac{1}{40} \gamma_1^2 \right) + \right. \\ &\quad \left. + \frac{1}{120} \alpha_1^2 \beta_1^2 + \frac{1}{6} \alpha_2 \beta_1 \left(1 + \frac{1}{40} \gamma_1^2 \right) + \frac{1}{120} \alpha_1 \beta_1 \gamma_1 \gamma_2 + \right. \\ &\quad \left. + \frac{1}{4} \gamma_2^2 \left(\frac{1}{6} + \frac{1}{80} \gamma_1^2 \right) \right\} \end{aligned} \tag{A-10}$$

$$c_1 = e^{\frac{\gamma_1}{2}} \beta_1 \left(1 + \frac{1}{24} \gamma_1^2 + \frac{1}{1920} \gamma_1^4 \right) \tag{A-11}$$

$$c_2 = e^{\frac{\gamma_1}{2}} \beta_1 \left(\frac{1}{6} \alpha_1 \beta_1 + \frac{1}{12} \gamma_1 \gamma_2 \right) \left(1 + \frac{1}{40} \gamma_1^2 \right) \tag{A-12}$$

$$d_1 = \hat{a}_1 + \frac{1}{2} \gamma_2 \tag{A-13}$$

$$d_2 = \hat{a}_2 + \frac{1}{8} \gamma_2^2 + \frac{1}{2} \gamma_2 \hat{a}_1 \tag{A-14}$$

ACKNOWLEDGMENT

Khuzestan Gas Company and Shahid Chamran University are acknowledged for providing technical, administrative, and financial assistance.

REFERENCES

- [1] E. B. Wylie, M. A. Stoner, and V. L. Streeter, "Network Transient Calculation by Implicit methods", Soc. Pet Eng. J., 1971, 356-362.
- [2] C. A. Luongo, "An Efficient Program for Transient Flow Simulation in Natural Gas Pipelines", 15th Annual Meeting Pipeline Simulation Interest Group (PSIG), New Orleans, October 1986.
- [3] W. Yow, "Analysis and Control of Transient Flow in Natural Gas Piping System", Ph.D. dissertation, U. of Michigan, Ann Harbor, 1971.
- [4] A. J. Osiadacz, "Simulation and Analysis of Gas Networks", E. & F.N. Spon, London, 1987.
- [5] S. O. Ibraheem and M. A. Adewumi, "Higher-Resolution Numerical Solution for 2-D Transient Natural Gas Pipeline Flows", Soc. of Petroleum Eng., SPE 35626, 1996, pp. 473-482.
- [6] T. Kiuchi, "An Implicit Method for Transient Gas Flow in Pipe Networks", Int. J. Heat and Fluid Flow, Vol. 15, No. 5, 1994, pp. 378-383.
- [7] Y. Dukhovnaya and A. Michael, "Simulation of non-isothermal transient in gas/condensate pipelines using TVD schemes", Petroleum and Natural Gas Eng., The Pennsylvania State University, USA., 2000.
- [8] J. Zhou and M. A. Adewumi, "Simulation of Transient Flow in Natural Gas Pipelines", the Pennsylvania State University, Petroleum and Natural Gas Engineering, GRI-PA 16802, 1996.
- [9] E. Tentis, D. Margaris, and D. Papanikas, "Transient gas flow simulation using an Adaptive Method of Lines", U. of Patras, C. R. Mechanics J., 2003, pp. 481-487.
- [10] S. L. Ke and H. C. Ti, "Transient analysis of isothermal gas flow in pipeline network", chemical eng. J., 1999, 169-177.
- [11] A. H. Gonzales, J. M. De La Cruz, B. D. Andres-Toro, and J. L. Risco-Martin, "Modeling and simulation of a gas distribution pipeline network", Applied Mathematical Modeling J., article in press, 2008.
- [12] H. P. Reddy, S. Narasimhan, and S. M. Bhallamudi, "Simulation and State Estimation of Transient Flow in Gas Pipeline Networks Using a Transfer Function Model", Department of Chemical Engineering and Department of Civil Engineering, Indian Inst. of Technology, Madras, Chennai-600036, India, 2006.
- [13] J. Kralik, P. Stiegler, Z. Vostry, J. Zavorka, "Dynamic modeling of large scale networks with application to gas distribution", 1st ed., Inst. of Information Theory and Automation of the Czechoslovak Academy of Sciences Prague, Czechoslovakia, ELSEVIER Amsterdam-Axford, 1998.
- [14] A. K. Hoffman and S. T. Chiang, "Computational Fluid Dynamics for Engineers", Wichita, Kansas, 2000.
- [15] T. D. Taylor, N. E. Wood, and J. E. Power, "A Computer Simulation of Gas Flow in Long Pipelines", Soc. Pet. Eng. J., Trans. AIME, 225, 1962, 1962, pp. 297-302.
- [16] A. Bagheri, "Evaluation of Various Numerical Algorithms for Transient Flow Computation in Natural Gas Networks and Dynamic Analysis of a Typical Case", M. Sc. Thesis, Mech. Eng. Dept., Shahid Chamran University, Ahvaz, Iran, (in preparation).