

Interference Reduction Technique in Multistage Multiuser Detector for DS-CDMA System

Lokesh Tharani, R.P.Yadav

Abstract—This paper presents the results related to the interference reduction technique in multistage multiuser detector for asynchronous DS-CDMA system. To meet the real-time requirements for asynchronous multiuser detection, a bit streaming, cascade architecture is used. An asynchronous multiuser detection involves block-based computations and matrix inversions. The paper covers iterative-based suboptimal schemes that have been studied to decrease the computational complexity, eliminate the need for matrix inversions, decrease the execution time, reduce the memory requirements and uses joint estimation and detection process that gives better performance than the independent parameter estimation method. The stages of the iteration use cascaded and bits processed in a streaming fashion. The simulation has been carried out for asynchronous DS-CDMA system by varying one parameter, i.e., number of users. The simulation result exhibits that system gives optimum bit error rate (BER) at 3rd stage for 15-users.

Keywords—Multi-user detection (MUD), multiple access interference (MAI), near-far effect, decision feedback detector, successive interference cancellation detector (SIC) and parallel interference cancellation (PIC) detector.

I. INTRODUCTION

THE tremendous increase in demand for wireless services has caused a search for techniques to improve the capacity of current digital wireless communication. To bring this vision for future, major improvements in the current state of wireless technology are necessary. One type of wireless technology which has become very popular over the last few years is direct sequence code division multiple access (DS-CDMA). Code Division Multiple Access (CDMA) is one of the several methods of multiplexing wireless users [1]. In CDMA, users are multiplexed by distinct codes rather than by orthogonal frequency band as in frequency-division multiple accesses (FDMA), or by orthogonal time slots as in time-division multiple access (TDMA). In CDMA, all users can transmit at the same time. Also, each user is allocated the entire frequency spectrum for transmission; hence, CDMA is also known as spread spectrum communications [2]. The DS-CDMA multiplier multiplies each user's signal by a distinct code waveform as shown in Fig. 1.

Manuscript received on April 7, 2008.

Lokesh Tharani is Assistant Professor in Electronics & Communication Engineering Department at the JaganNath Gupta Institute of Engineering and Technology (JNIT), Sitapura, Jaipur, Rajasthan, India (phone: 009414238103; fax: +91-0141-2771618; e-mail: tharani123@gmail.com)

Dr. R.P.Yadav is Professor and Head of Electronics & Communication Engineering Department at Malaviya National Institute of Technology (MNIT), Jaipur, Rajasthan, India (e-mail: rp_yadav@yahoo.com).

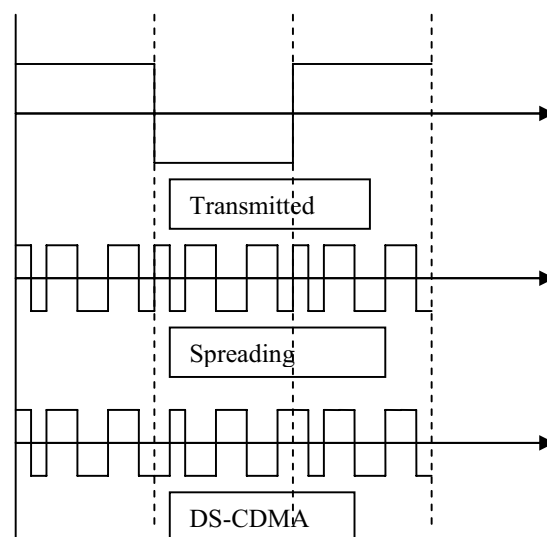

Fig. 1 DS-CDMA Modulation with spreading gain $N=7$

In DS-CDMA system multiple access interference (MAI) is the major factor limiting the performance and, hence, the capacity of the system. The interference from other users is known as multiple access interference (MAI). This interference is the result of random time offsets between signals, which makes it impossible to design the code waveform to be completely orthogonal. While the MAI caused by any one user is generally small, as the number of interference or their power increases, MAI becomes substantial. Therefore, analysis of the effect of MAI on the system performance as well as ways to suppress MAI has been the major focus of CDMA research. There are two basic approaches to solve this problem. The first approach is based on the concept of single user detection. In this approach, we identify one of the users in the system as the desired user and treat all signals from the other users as interference. The receiver (for the desired user) detects only the desired user signal. The second approach is called multi-user detection [3]. The code and timing (or amplitude & phase) information of multiple users are jointly used to better detection of signal of individual user is known as multiuser detection. The important assumption is that the codes of the multiple users are known to the receiver a priori. Theoretically, receivers based on multi-user detection [4, 5] usually outperform, but are usually more complex than receivers based on single-user detection. The applicability of multi-user receivers depends on system design issues, such as the security of joint detection, the

implementation complexity, and the availability of information required performing multi-user detection. For example, let us consider a typical wireless cellular system. It would be difficult to employ multi-user receivers at the mobile units for forward-link transmission because of the limitation on the implementation complexity and the availability of information about other users. However, multi-user detection could be a viable choice in the base-station for reverse-link transmission. Verdu's seminal work published in 1986, proposed and analyzed the optimal multi-user detector that proved to be much complex for practical DS-CDMA systems. Therefore, over the last two decades or so, research has focused on finding suboptimal multi-user detector solutions [6], which are more feasible to implement.

II. CONVENTIONAL DS-CDMA DETECTOR

Now-a-days single user matched filter detection technique is using in mobile communication. Although easy to implement, the performance severely degrades when the number of users goes up. The conventional detector [7] consists of a matched filter bank (a series of transversal filters in parallel), with one filter corresponding to each user as shown in Fig. 2. The received signal is correlated with the signature waveform of each user, and the output is used to determine the bits transmitted by each user.

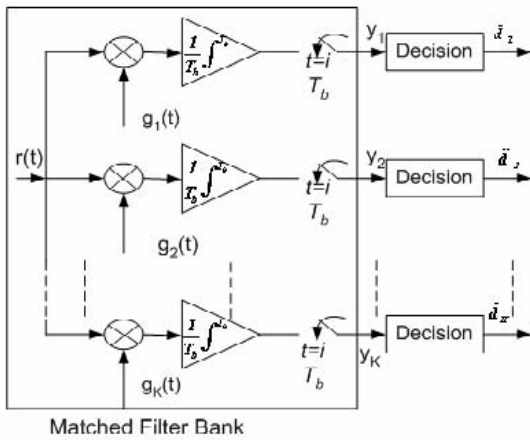

Fig. 2 The conventional DS-CDMA detector with a Matched Filter Bank

This detector relies on the fact that the signature sequences of any two users are close to orthogonal. It is to be noted that the matched filter receiver is not optimal (in the sense of maximizing the likelihood function) in the presence of MAI. Assuming there are K direct-sequence users in an asynchronous single path BPSK real channel, the base band received signal can be expressed as

$$r(t) = \sum_{k=1}^K A_k(t) g_k(t) d_k(t) + n(t) \tag{1}$$

where $A_k(t)$, $g_k(t)$, and $d_k(t)$ are the amplitude, signature code waveform and modulated data of the k' th user respectively and $n(t)$ is additive white Gaussian noise (AWGN), with a two

sided power spectral density of $N_0/2$ W/Hz. The conventional detector for received signal described in equation (1) is a bank of K correlators as shown in Fig..2. This figure shows that each code waveform is regenerated and correlated with the received signal in a separate detector branch of the matched filter detector. It is evident from this figure that the conventional detector follows a single user strategy, whereby each branch detects one user without regard to the existence of other users. Thus there is no sharing of multi-user information. The success of this detector depends on the properties of the correlations between codes [8]. We require the autocorrelation to be much larger than the cross-correlation of different codes [9]. The correlation value is defined as:

$$\rho_{i,k} = \frac{1}{T_b} \int_0^{T_b} g_i(t) g_k(t) dt \tag{2}$$

Here, if $i = k$, $\rho_{k,k} = 1$, and if $i \neq k$, $0 \leq \rho_{i,k} < 1$. The output of the k'th user's correlator for a particular bit interval is

$$\begin{aligned} y_k &= \frac{1}{T_b} \int_0^{T_b} r(t) g_k(t) dt \\ &= A_k d_k + \sum_{\substack{i=1 \\ i \neq k}}^k \rho_{i,k} A_i d_i + \frac{1}{T_b} \int_0^{T_b} n(t) g_k(t) dt \\ &= A_k d_k + MAI_k + Z_k \end{aligned} \tag{3}$$

The correlation with the k'th user itself gives rise to the recovered data term; correlation with all the other users gives rise to multiple access interference (MAI), and correlation with the thermal noise gives the term Z_k .

III. CONCEPT OF MULTISTAGE PARALLEL INTERFERENCE CANCELLATION

This Parallel Interference Cancellation (PIC) detector estimates and subtracts out all of the MAI got each user in parallel. The n'th stage of this detector uses decisions of the (n-1)'th stage to cancel MAI present in the received signal. Thus, maximization is over one bit a time, instead of over k bits. The Fig.3 shows this concept.

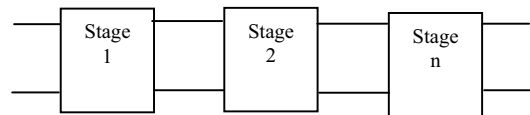

Fig. 3 The concept of multistage detector

For the first stage we use either decorrelator [10] or matched filter. So output of the first stage multistage detector for two-user case is given here for example.

$$\hat{d}_1^{(1)} = \text{Sgn}(r_1 - \rho_{12} r_2) \tag{4}$$

$$\hat{d}_2^{(1)} = \text{Sgn}(r_2 - \rho_{21} r_1) \tag{5}$$

Here ρ_{12} and ρ_{21} is the cross correlations between users, r_1 and r_2 are received signals at input of first stage and d_1 & d_2 are output of stages of detectors. The outputs of the next stages find as similar to previous equations.

$$\hat{d}_1^{(2)} = \text{Sgn} (r_2 - \rho_{21}A_1 \hat{d}_2^{(1)}) \tag{6}$$

$$\hat{d}_2^{(2)} = \text{Sgn} (r_2 - \rho_{21}A_1 \hat{d}_1^{(1)}) \tag{7}$$

$$n^{\text{th}} \text{ stage } \hat{d}_j^{(n)} = \text{Sgn} (r_j - \sum_{L \neq j}^K A_K \rho_{Kj} \hat{d}_K(n-1)) \tag{8}$$

where $j = 1, 2, \dots, K$, A_K is the amplitude of received signal. The n^{th} stage of this detector user decision of the $(n-1)^{\text{th}}$ stage to cancel MAI present in the received signal.

IV. MULTIUSER CHANNEL ESTIMATION AND DETECTION

The 3G wireless system such as third generation partnership project (3GPP) or universal mobile telecommunication system (UMTS) can provides variable data transmission rate such as from 32 kbps to 2 mbps depending on the spreading factors (N) which varies from 256 (vehicular traffic) to 4 (for indoor environment) respectively. We have taken binary phase shift keying (BPSK) modulation (1 bit/symbol) in own simulation, so data rates varies in the range from 16 kbps to 1 mbps. The base station receiver receives addition of the signal of all the active users after they travel through different paths in the channel [11]. The multipath is caused due to reflection, diffraction and scattering of the transmitted signal that arrives at the receiver along with the line-of-sight component.

These channel paths induce different delays, alternative and phase shifts to the signal and the mobility of the users causes fading in the channel. Moreover, the signals from different users also interfere with each other in addition to the additive white Gaussian noise (AWGN) percent in the channel. The channel estimation of multi user system refers to the joint estimation of these unknown parameters for all users to mitigate these undesirable effects and accurately detect the received bits of different users. Multiuser detection is the process of the detection of the received bits for all users jointly by canceling the interference between the different users. The performance of multiuser detection mainly depends on the accuracy of the channel estimation [12]. For an asynchronous system with binary phase shift keying modulation, the channel estimate of the multipath signal can be expressed as

$$r_i = A d_i + n_i \tag{9}$$

in matrix form equation (9) can be written as

$$r_i = [A_0 \ A_1] \begin{bmatrix} d_{1, i-1} \\ \vdots \\ d_{k, i-1} \\ d_{1, i} \\ \vdots \\ d_{k, i} \end{bmatrix} + n_i \tag{10}$$

where r_i is the received signal vector after chip matched filtering, A is the effective spreading code matrix of dimension $N \times 2K$ containing information about spreading codes, attenuation and delay from various paths, $d_i \in \{-1, +1\}^{2K}$ are the bits of K users to be detected and n_i is the AWGN. The bits d_i , of the K^{th} users to be detected lie between the received signal r_i and r_{i-1} boundaries.

A. Matched Filter (MF) Detector

The bits d_i , of the K users to be detected lie between the received signal r_i and r_{i-1} boundaries. The matched filter detector do a process of correlation of the input bits with the received bits. Hence, the matched filter detector shows as

$$\hat{d}_i = \text{Sgn} (\Re [A_1^H r_{i-1} + A_0^H r_i]) \tag{11}$$

The multistage detector user this matched filter output to get an initial estimate of the bits and then iteratively subtracted the interference from all other users.

B. Multistage Detector

The multistage detector performs parallel interference cancellation iteratively in stages [13]. Due to asynchronous users the desired user's bits suffers from interference caused by the past or future overlapping symbols. That's why the multishot detection [14] is needed to cancel these interferences. For multishot detection the described system in equation (9) should be extended to include multiple bits. Let us consider D bits at a time ($i = 1, 2, \dots, D$). So we form the multishot received vector matrix r of dimension of ND . Where A represent the new multishot channel matrix of dimension $ND \times KD$ and A_0 & A_1 it's odd and even columns.

$$r = \begin{bmatrix} A_0 & A_1 & 0 & 0 \\ 0 & A_0 & A_1 & 0 \\ \vdots & \ddots & \ddots & A_1 \\ 0 & 0 & 0 & A_0 \end{bmatrix} \begin{bmatrix} d_{1, 1} \\ \vdots \\ d_{k, 1} \\ d_{1, D} \\ \vdots \\ d_{k, D} \end{bmatrix} + n_i \tag{12}$$

The initial soft decision outputs $y^{(o)}$ and hard decision output $\hat{d}^{(o)}$ of the detector belongs to receive signal vector matrix of dimension KD and obtained from matched filter using the channel estimates as given in equations(13)-(16).

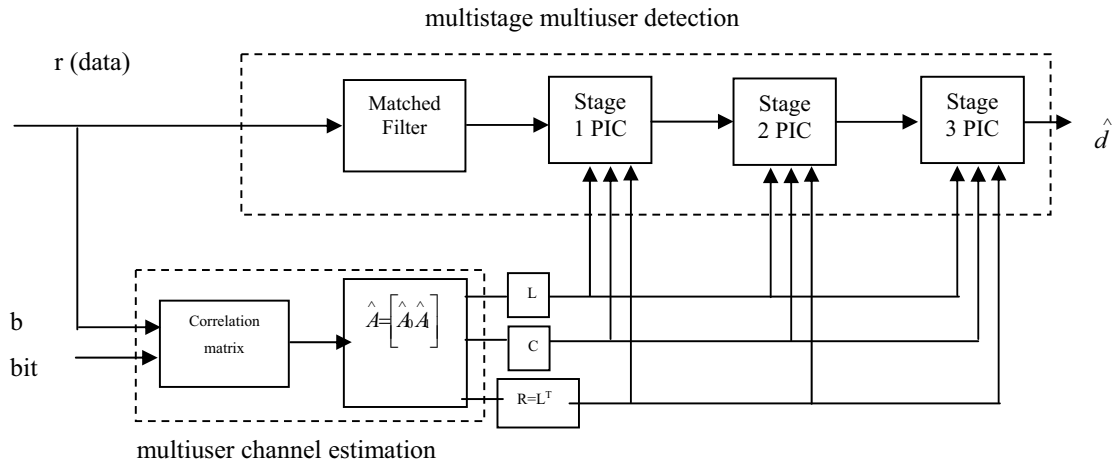

Fig. 4 The joint process of channel estimation and detection

$$y^{(0)} = \Re [A^H r] \tag{13}$$

$$\hat{d}^{(0)} = \text{Sgn} [y^{(0)}] \tag{14}$$

$$y^{(l)} = y^{(0)} - \Re [A^H A - \text{diag} (A^H A)] \hat{d}^{(l-1)} \tag{15}$$

$$\hat{d}^{(l)} = \text{Sgn} [y^{(l)}] \tag{16}$$

where $y^{(l)}$ and $\hat{d}^{(l)}$ are the soft and hard decision respectively after each stage of the multistage detector and l is the number of iteration (stages), $l = 1, 2, \dots, M$ were minimum number of iteration chosen for simulation (typically 4).

C. Cascade Multistage Detection

The stages in the multistage detector [15, 16, 17] can be efficiently cascading to avoid the edge computations and work on bit streaming basis. The computations performed on the intermediate bits in simulation reduced to

$$L = \Re \begin{bmatrix} \hat{A}_1^H & \hat{A}_0^H \\ \hat{A}_1 & \hat{A}_0 \end{bmatrix} \tag{17}$$

$$C = \Re \begin{bmatrix} \hat{A}_0^H & \hat{A}_0^H + \hat{A}_1^H & \hat{A}_1^H \\ \hat{A}_0 & \hat{A}_0 + \hat{A}_1 & \hat{A}_1 \end{bmatrix} \tag{18}$$

$$y_i^l = y_i^0 - L \hat{d}_{i-1}^{(l-1)} - C \hat{d}_i^{(l-1)} - L^T \hat{d}_{i+1}^{(l-1)} \tag{19}$$

$$\hat{d}_i^l = \text{sgn} [y_i^l] \tag{20}$$

where $L \in \mathbb{R}^{K \times K}$ shows the left matrix stands for the partial correlation between the past bit of the interfering user and the desired user. $C \in \mathbb{R}^{K \times K}$ shows the center matrix, stands for the correlation of the current bits of interfering users and the diagonal elements are made zeros since only the interference from other user exists and $R=L^T$ shows the partial correlation between the future bits of the interfering user and the desired user. The lower indexes i represent time while the upper index l , represent the iterations. The detection can now be cascading

as shown in Fig. 4. The first stage of initial estimate of the received signal is done using a matched filter detector. This only depends on the current and the past-received bits. The successive stages of multistage detector [18, 19] need future and past bits of all users to cancel the interference from present bit. Hence, the first stage can cancel the interference only after the bit 1 and 3 estimates of the matched filter are available. The similar structure follows by other stages. The detector takes the matched filter estimates Y_i and hard decision \hat{d}_i . The partial correlation matrixes L, C are also estimated and subtracts from iteratively in stages from the matched filter output. Each stage of the detector sends a delayed matched filter estimate and the updated hard decision to the next stage of the detector.

V. SIMULATION AND PERFORMANCE CRITERIA

The multistage multiuser detection for CDMA communication described in section 4 was simulated in MATLAB [20], particularly popular in wireless communication. In simulation process, mainly one parameters was varied, the number of users from 10 to 30 for multistage detector. The parameters were used for simulation as follows.

TABLE I
SIMULATION PARAMETERS FOR MULTISTAGE MULTIUSER DETECTOR

Parameter	Value
Window length (L)	128
Spreading gain (N)	32
Signal to interference noise ratio (SINR)	0 dB
Number of paths (P)	3
Signal to noise ratio (SNR)	3,5,7,8,9,10,12,14 & 16 dB
Number of users	10,15,20,25 & 30
Number of parallel interference cancellation (PIC) stages	4

The performance criteria for evolution of multistage multiuser detector [21, 22] is bit error rate (BER) has been taken for this paper. The reduced bit error rate shows reduced

multiple access interference, thus the capacity of the system will increase.

VI. SIMULATION RESULTS

Tables II-VI shown below the bit error rate for users 10, 15, 20, 25 and 30 respectively against different signal to noise ratios (SNR) for 4-stage multiuser detector.

TABLE II
BER OF MULTISTAGE DETECTOR FOR 10 USERS

SNR (dB)	Matched Filter (BER)	PIC Stage-1 (BER)	PIC Stage-2 (BER)	PIC Stage-3 (BER)	PIC Stage-4 (BER)
3	0.1485	0.1452	0.1429	0.1422	0.1525
5	0.1028	0.0926	0.0877	0.0891	0.0994
7	0.0674	0.0486	0.0453	0.0455	0.0563
8	0.0540	0.0336	0.0323	0.0323	0.0400
9	0.0439	0.0225	0.0206	0.0206	0.0280
10	0.0362	0.0143	0.0135	0.0135	0.0189
12	0.0243	0.0047	0.0036	0.0036	0.0092
14	0.0166	0.0011	0.0005	0.0005	0.0040
16	0.0126	0.0005	0.0002	0.0002	0.0011

TABLE III
BER OF MULTISTAGE DETECTOR FOR 15 USERS

SNR (dB)	Matched Filter (BER)	PIC Stage-1 (BER)	PIC Stage-2 (BER)	PIC Stage-3 (BER)	PIC Stage-4 (BER)
3	0.1303	0.1269	0.1195	0.1183	0.1323
5	0.0911	0.0759	0.0663	0.0661	0.0805
7	0.0669	0.0389	0.0327	0.0317	0.0442
8	0.0585	0.0232	0.0217	0.0199	0.0309
9	0.0524	0.0136	0.0133	0.0126	0.0231
10	0.0467	0.0127	0.0088	0.0081	0.0159
12	0.0407	0.0075	0.0044	0.0040	0.0093
14	0.0371	0.0044	0.0021	0.0019	0.0061
16	0.0347	0.0030	0.0013	0.0010	0.0045

TABLE IV
BER OF MULTISTAGE DETECTOR FOR 20 USERS

SNR (dB)	Matched Filter (BER)	PIC Stage-1 (BER)	PIC Stage-2 (BER)	PIC Stage-3 (BER)	PIC Stage-4 (BER)
3	0.1580	0.1635	0.1462	0.1470	0.1658
5	0.1211	0.1069	0.0892	0.0891	0.1148
7	0.0912	0.1621	0.0489	0.0487	0.0721
8	0.0806	0.0471	0.0349	0.0344	0.0560
9	0.0721	0.0344	0.0226	0.0234	0.0440
10	0.0645	0.0246	0.0155	0.0154	0.0336
12	0.0505	0.0127	0.0067	0.0064	0.0200
14	0.0425	0.0080	0.0029	0.0024	0.0127
16	0.0381	0.0052	0.0014	0.0008	0.0092

TABLE V
BER OF MULTISTAGE DETECTOR FOR 25 USERS

SNR (dB)	Matched Filter (BER)	PIC Stage-1 (BER)	PIC Stage-2 (BER)	PIC Stage-3 (BER)	PIC Stage-4 (BER)
3	0.1684	0.1885	0.1624	0.1657	0.1843
5	0.1325	0.1317	0.1117	0.1103	0.1314
7	0.1098	0.0884	0.0672	0.0690	0.0922
8	0.1011	0.0699	0.0510	0.0489	0.0718
9	0.0944	0.0571	0.0386	0.0351	0.0560
10	0.0889	0.0451	0.0286	0.0250	0.0482
12	0.0797	0.0304	0.0167	0.0126	0.0301
14	0.0736	0.0221	0.0103	0.0072	0.0162
16	0.0704	0.0181	0.0079	0.0052	0.0141

TABLE VI
BER OF MULTISTAGE DETECTOR FOR 30 USERS

SNR (dB)	Matched Filter (BER)	PIC Stage-1 (BER)	PIC Stage-2 (BER)	PIC Stage-3 (BER)	PIC Stage-4 (BER)
3	0.1779	0.1975	0.1701	0.1725	0.2046
5	0.1460	0.1442	0.1219	0.1231	0.1514
7	0.1233	0.1032	0.0827	0.0814	0.1122
8	0.1135	0.0869	0.0689	0.0655	0.0968
9	0.1054	0.0735	0.0570	0.0557	0.0860
10	0.0980	0.0631	0.0478	0.0443	0.0732
12	0.0888	0.0476	0.0355	0.0322	0.0581
14	0.0826	0.0399	0.0285	0.0261	0.0502
16	0.0785	0.0352	0.0246	0.0223	0.0441

Now Fig. 5 (a)- (e) shown below plot the graph between bit error rate and signal to noise ratio for users 10, 15, 20, 25 and 30 respectively for 4-stage multiuser detector.

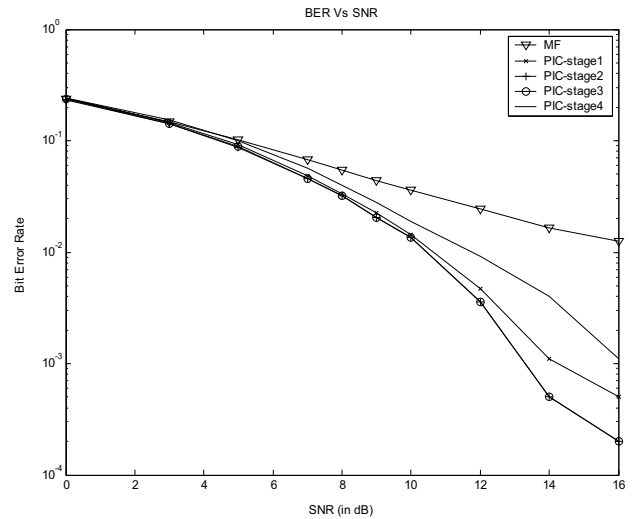

(a)

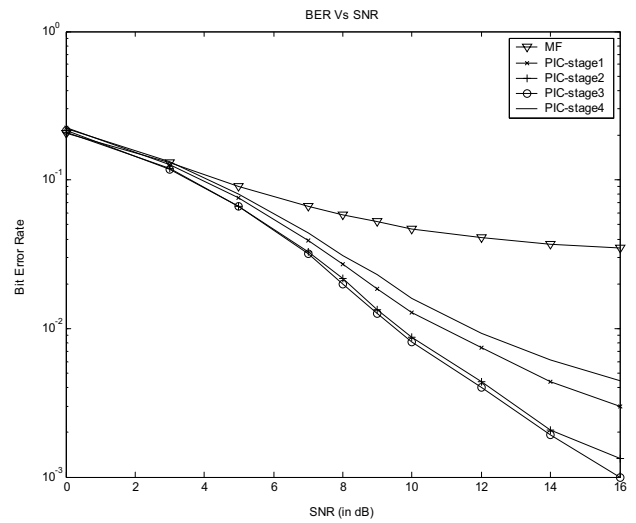

(b)

VII. CONCLUSION

Iterative technique has been used for the estimation of channel parameters that reduces the complexity, eliminates the matrix inversion process, decreases the execution time and reduces the memory requirements. The paper deals with two basic concepts, i.e., multistage detector and multiuser detector. In multistage detector the number of stages increases, the detection is more reliable and bit error rate (BER) also decreases but after 3rd stage, there is increase in BER because of increase in delay for computation and increases the multiple access interference between users. The multiuser concept gives mainly two advantages in comparison to single user detector; it eliminates the near-far problem and also it reduces the multiple access interference (MAI) so BER is reduced, thus the capacity of the system will increased. Table III and IV show that if the number of user increases from 15 to 20, BER is increases because of more multiple access interference. So it can be concluded that this 4-stage multiuser detector gives better performance at 3rd stage for 15-users.

ACKNOWLEDGMENT

The authors acknowledge the pioneer work done by Prof. Joseph R. Cavallaro, Prof. Behnaam Aazhang and many others researchers in this area.

REFERENCES

- [1] Lokesh Tharani and Dr. R.P.Yadav, "Performance evaluation of multistage multiuser detector for asynchronous DS-CDMA system" IEEE Proceeding of International Conference on Computational Intelligence and Multimedia Applications 2007 (ICCIMA-07), Volume IV, page No. 316-321, Sivakasi, Tamilnadu, India, Dec 2007
- [2] Andrew J. Viterbi, "CDMA Principles of Spread Spectrum Communication", Addison Wesley Longman, ISBN: 0201-63374-4.
- [3] Sergio Verdu, "Multi-user detection", Cambridge University Press. ISBN: 0521-59373-5.
- [4] Duel-Hallen, J. Holtzman, and Z. Zvonar, "Multi-user detection for CDMA systems,". IEEE Personal Communications Magazine, April 1995.
- [5] Louis G.F. Trichard, "Optimal Multistage Linear Multiuser Receivers", IEEE Transaction on Wireless Communication, Vol. 4, NO. 3, May 2005
- [6] S. Moshavi, "Multi-user detection for DS-CDMA communications", IEEE communications magazine, Vol. 34, No. 10, page no. 124-136, October, 1996.
- [7] H. V. Poor, S. Verdu, "Single-user detectors for multiuser channels," IEEE Trans. Comm. Vol. 36, no. 1, pp. 50-60, Jan. 1988.
- [8] R. Lupas, S. Verdu, "Near-far resistance of multiuser detectors in asynchronous channels," , IEEE Trans. Comm. Vol. 38, no. 4, pp. 496-508, April 1990.
- [9] Tan F. Wong: "Spread spectrum & CDMA". www.wireless.ece.ufl.edu/twong/Notes/CDMA/ch6.pdf.
- [10] John G. Prokis, "Digital communication", forth edition, McGraw-Hill International, 2001.
- [11] Zartash Afzal Uzmi, "Simplified multiuser detection for CDMA systems", Ph.D., Thesis, September, 2002
- [12] H.Y.Wu and A. Duel-Hallen," Performance comparison of multiuser detectors with channel estimation for flat rayleigh fading CDMA channels," Wireless Pres. Communication., July/august 1996
- [13] Shridhar Rajgopal, Shrikrishna Bhashyam, Joseph R. Cavallaro and Behnaam Aazhang, "Real-Time Algorithms and Architectures for Multiuser Channel Estimation and Detection in Wireless Base Station

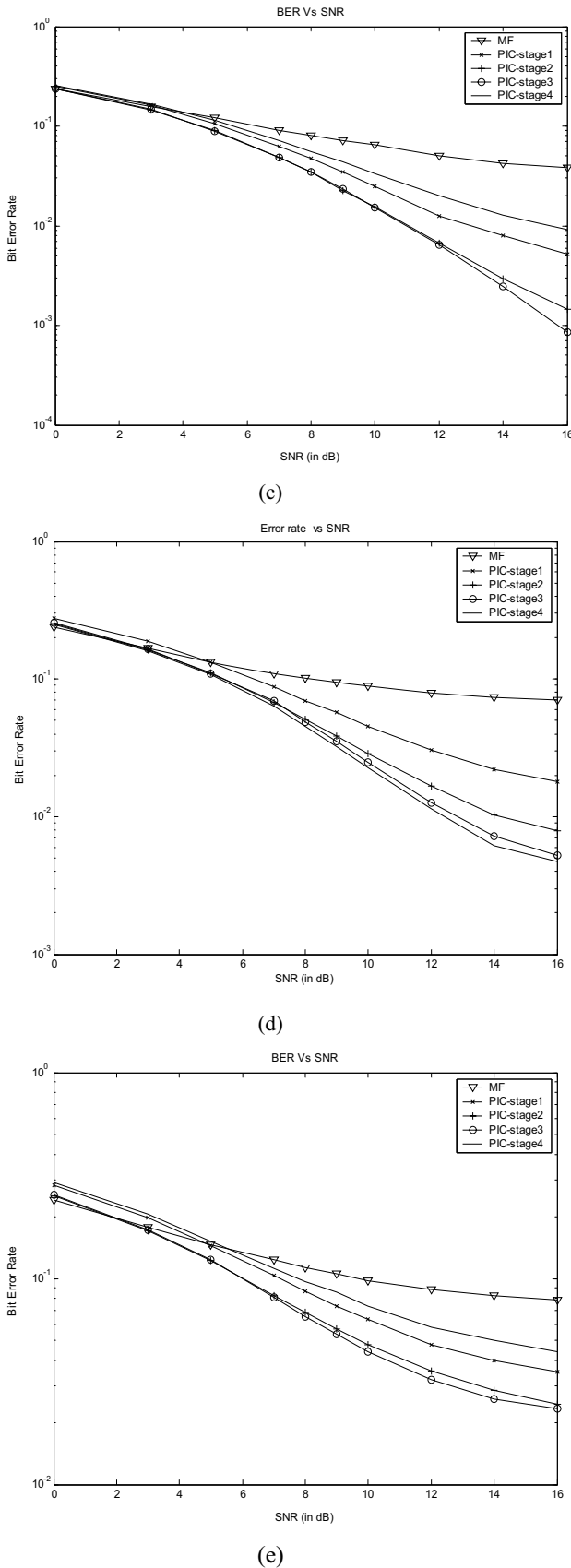

Fig. 5 BER Vs SNR for Multistage Detector with (a) 10- users, (b) 15- users, (c) 20- users, (d) 25- users and (e) 30- users

- Receivers”, IEEE Transactions on Wireless Communications, Vol. 1, No. 3, July 2002.
- [14] R..Michael Buehrer, Neiyer S. Correal-Mendoza and Brain D. Woerner,” A simulation comparison of multiuser receivers for cellular CDMA”, IEEE Transactions on Vehicular Technology, Vol. 49, No. 4, July, 2000.
- [15] Lokesh Tharani and Dr. R.P. Yadav, “Non- Linear suboptimal multiuser detectors for DS-CDMA systems”, Proceedings of International conference on soft computing and Intelligent System (ICSCIS-07), Jabalpur Engineering College, Jabalpur(M.P.), Vol. 3, page NO. 176-180, December, 2007.
- [16] Cottatellucci, Laura;Debbah, Merouane;Muller, Ralph R, “Linear multiuser detection for CDMA systems with correlated spatial diversity”, ISCCSP 2006, IEEE 2nd International Symposium on Communications, Control and Signal Processing, 13-15 March 2006, Marrakech, Morocco.
- [17] Cottatellucci, Laura;Debbah, Merouane;Müller, Ralf R, “Asymptotic design and analysis of multistage detectors for asynchronous CDMA systems”, ISIT 2004, IEEE International Symposium on Information Theory, June 27 - July 2, 2004, Chicago, USA , pp 509- 509.
- [18] Seung Hee Han and Jae Hong Lee, “Multi-stage partial PIC receivers for multi_rate DS-CDMA system with multiple modulation,” in Proc. of the IEEE WCNC 2003, pp. 591-594, Mar. 2003.
- [19] Jerome M. Shapiro and James Durnyak, “Soft Information in Interference Cancellation Based Multiuser Detection”, submitted for IEEE transaction on Wireless Communication, July 2005.
- [20] Stephen J. Chapman, “MATLAB Programming for Engineering”, Second Edition, Thomson Publication.
- [21] A. Rajeswari, K.Gunavathi and A.Shanmugam,“A Selective Survey on Multiuser Detection Techniques in CDMA Systems”, Academic Open Internet Journal, Volume 13, 2004.
- [22] Halil Tanyer Eyyuboglu,“MATLAB Simulation of Multiuser Detection in CDMA”, Proceeding of World Academy of Science, Engineering and Technology, volume 3, January 2005.

Lokesh Tharani has done BE (Honors) from Govt. Engineering College Kota (Now RTU) in 1999 and completed M.Tech. (Honors) in Electronics & Communication Engineering from Malaviya National Institute of Technology (MNIT), Jaipur, August 2003. He is also pursuing his Ph.D. in CDMA Technology from MNIT, Jaipur. He has a teaching experience of more than 8 years and has published several papers in national & international symposiums and conferences. He is also author of book “Wireless Communication “.

Dr. R.P.Yadav received M. Tech. degree in Integrated Electronics and Circuits in 1987 from Electrical Engineering Department, Indian Institute of Technology (IIT), Delhi and completed Ph.D. in Communication Engineering from University of Rajasthan in 2001. He is active member of various professional bodies like IEEE and IETE. He has published over 50 papers in national & international journals and conferences. He actively involves in research areas like MIMO, adhoc networking, multiuser detection, information theory & coding and microstrip antennas.