

# Artificial Voltage-Controlled Capacitance and Inductance using Voltage-Controlled Transconductance

Mansour I. Abbadi and Abdel-Rahman M. Jaradat

**Abstract**—In this paper, a technique is proposed to implement an artificial voltage-controlled capacitance or inductance which can replace the well-known varactor diode in many applications. The technique is based on injecting the current of a voltage-controlled current source onto a fixed capacitor or inductor. Then, by controlling the transconductance of the current source by an external bias voltage, a voltage-controlled capacitive or inductive reactance is obtained. The proposed voltage-controlled reactance devices can be designed to work anywhere in the frequency spectrum. Practical circuits for the proposed voltage-controlled reactances are suggested and simulated.

**Keywords**—voltage-controlled capacitance, voltage-controlled inductance, varactor diode, variable transconductance.

## I. INTRODUCTION

ONE of the most important inventions which introduced great advancements in modern telecommunication systems and other electronic systems is the varactor or varicap (variable capacitance). The varactor diode is a reverse biased PN junction whose depletion capacitance can be controlled by its bias voltage. Before the invention of the varactor diode, all communication transmitters and receivers are tuned manually (mechanically) to the desired operating frequency using bulky rotary variable capacitors or moving coil variable inductors [1]. The advent of the varactor diode in 1956 [2] made possible the design of voltage-controlled oscillators and phase-locked loop frequency synthesizers with the capability of controlling the operating frequency either remotely as in TV sets, or under the control of microprocessors and microcontrollers as in mobile telephone systems. However, varactor diode has many drawbacks such as its small depletion capacitance which ranges from few picofarads to several tens of picofarads which means small tuning range [3]. Another drawback is the nonlinear relation between the control bias voltage and the depletion capacitance. In spite of these drawbacks, the varactor diode remains unchallenged for the last fifty years where no other voltage-controlled capacitance device is found to replace it in the different applications.

Few attempts are reported in the literature which tried to find an alternative to the varactor diode and overcome some of its drawbacks specially the small tuning range. The first attempt is to use actively synthesized capacitor based on the Miller effect where the capacitance between the input and the output of an inverting amplifier is multiplied by a factor of  $(1 - A_v)$ , where

The authors are with the Department of Electrical Engineering, Jordan University of Science and Technology, Irbid, Jordan 22110, email: mabbadi@just.edu.jo, amjaradat@just.edu.jo.

$A_v$  is the voltage gain of the amplifier and by controlling the gain of the amplifier a variable capacitance can be obtained [4]. This technique is found to extend the tuning range larger than that of the varactor diode in GHz-range applications [5]. In the second attempt, a balanced variable impedance converter is used as a voltage-controlled capacitance where it is based on the idea that the signal current flowing through a floating capacitor is tuned with a current steering circuit [6].

In this paper, a novel technique is proposed to implement an artificial voltage-controlled capacitance or inductance reactance. The technique is based on injecting the current of a voltage-controlled current source onto a given fixed capacitor or inductor. By controlling the transconductance of this current source using an external bias voltage, a voltage-controlled capacitance or inductance reactance can be obtained. In section 2, the basic theory of the proposed voltage-controlled reactance is presented. Practical circuits for the proposed voltage-controlled reactance with the simulation results are given in section 3. Conclusions are given in section 4.

## II. THEORY OF THE PROPOSED VOLTAGE-CONTROLLED REACTANCE DEVICE

The proposed artificial voltage-controlled capacitive or inductive reactance devices are based on injecting the current of a voltage-controlled current source into a fixed capacitor or inductor. The voltage which controls the current source must be in phase with the input current to the fixed reactive device. This can be done by inserting a small resistor in series with the fixed reactive device and make the voltage drop across it to control the current source. The desired voltage-controlled reactance can be obtained by controlling the transconductance of the current source by an external bias voltage. Such voltage-controlled current source with a voltage-controlled transconductance can be easily implemented using BJT and FET amplifiers. In the following the basic circuits for the proposed voltage-controlled capacitive and inductive reactances are presented and analyzed.

### A. Voltage-controlled capacitive reactance

Fig. 1 shows the basic circuit which illustrates the operating principle of the proposed voltage-controlled capacitive reactance. It consists of a resistor  $R$  in series with a fixed capacitor  $C_o$  and a voltage-controlled current source which injects its current  $g_m V$  into the fixed capacitor. The control voltage  $V$  of the current source is taken across the resistor

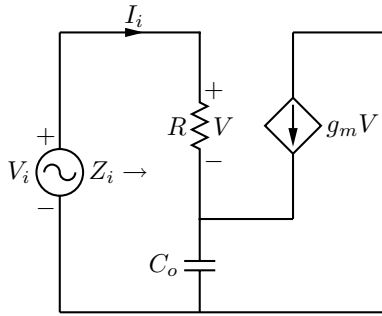

Fig. 1 A basic circuit for the artificial voltage-controlled capacitive reactance.

$R$  to ensure that the injected current has the same phase as the input current  $I_i$ . The input impedance looking across the combination of the resistor and the capacitor can be found using the following two equations:

$$V_i = I_i(R - jX_{C_o}) - jX_{C_o}g_m V \quad (1)$$

and

$$V = I_i R \quad (2)$$

Where  $g_m$  is the transconductance of the current source and  $X_{C_o} = 1/(\omega C_o)$  is the capacitive reactance of the fixed capacitor.

By substituting (2) in (1) and dividing both side by  $I_i$ , the input impedance  $Z_i$  of the circuit is found to be:

$$Z_i = R - jX_{C_o}[1 + g_m R] \quad (3)$$

It is obvious from (3) that the effective capacitive reactance of this circuit is increased by a factor of  $(1 + g_m R)$  over its original value due the injected current of the current source. The effective capacitance  $C_{eff}$  of this circuit is given by:

$$C_{eff} = C_o/(1 + g_m R) \quad (4)$$

The effective capacitance  $C_{eff}$  given in (4) can be controlled electronically (voltage-controlled) by using a voltage-controlled transconductance  $g_m$ . Such a voltage-controlled transconductance can be implemented using BJT or FET amplifiers whose transconductance is controlled linearly by an external bias voltage as we will discuss that in the next section. This artificial capacitor has many advantages over the well-known varactor diode. Firstly, the tuning range can be set anywhere in the frequency spectrum by choosing a proper value for the fixed capacitor  $C_o$  provided the availability of a voltage-controlled current source in that region. Secondly, the range of tuning can be increased easily by either widening the range of the transconductance or by increasing the value of the resistor  $R$ . Thirdly, the capacitive reactance has a linear relationship with the transconductance when the transconductance is controlled in a linear manner by the external bias voltage. Fourthly, small capacitances can be obtained from large capacitances by increasing the values of the transconductance  $g_m$  or the control resistance  $R$ .

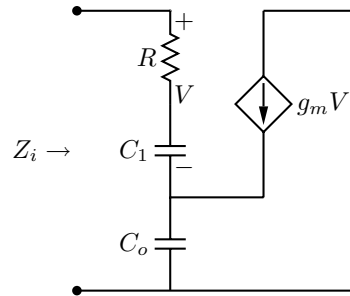

Fig. 2 A modified basic circuit for the artificial voltage-controlled capacitive reactance with negative resistance.

The input impedance  $Z_i$  in (3) has a resistance  $R$  which will degrade the  $Q$  factor of this circuit when it is used in some applications such as voltage-controlled oscillators. This impedance can be made either pure capacitive reactance or impedance with negative resistance by adding another capacitor  $C_1$  in series with the resistor  $R$  as it is shown in Fig. 2.

Notice that in this modified circuit, the current source injects its current onto capacitor  $C_o$  only and the control voltage of the current source is taken across both  $R$  and  $C_1$ . The input impedance of the modified circuit of Fig. 2 can be found using the following two equations:

$$V_i = I_i[R - j(X_{C_o} + X_{C_1})] - jX_{C_o}g_m V \quad (5)$$

and

$$V = I_i(R - jX_{C_1}) \quad (6)$$

By substituting (6) in (5) and dividing both side by  $I_i$ , the input impedance  $Z_i$  of the modified circuit is given by:

$$Z_i = (R - g_m X_{C_o} X_{C_1}) - j[X_{C_1} + X_{C_o}(1 + g_m R)] \quad (7)$$

The effective capacitive reactance of this circuit is the same as that of circuit in Fig. 1 except for the additional fixed reactance of the capacitor  $C_1$ . The second term in the real part of the impedance in (7) is a negative resistance whose value is determined by the product of  $g_m$ ,  $X_{C_o}$  and  $X_{C_1}$ . The magnitude of the negative resistance can be chosen to be equal to or higher than the positive resistance  $R$  to make the real part of the impedance zero or negative which is a necessary oscillation condition for oscillators. But since the transconductance has to be varied to get a variable capacitance, the real part of the impedance in (7) is also a varying quantity and this has to be taken into consideration in designing the circuit for the different types of application.

### B. Voltage-controlled inductive reactance

A voltage-controlled inductance can be obtained by using a similar circuit as that of the voltage-controlled capacitance where the capacitor  $C_o$  in Fig. 1 is replaced by an inductor  $L_o$ . Using a similar analysis, the input impedance looking across the resistor and the inductor is found to be:

$$Z_i = R + jX_{L_o}[1 + g_m R] \quad (8)$$

Where  $X_{L_o} = \omega L_o$  is the inductive reactance of  $L_o$ . The imaginary part of the impedance in (8) is an inductive reactance and it can be controlled by a voltage-controlled transconductance. It is obvious from (8) that the effective inductive reactance of this circuit is increased by a factor of  $(1 + g_m R)$  due the injected current from the voltage-controlled current source. The effective inductance of this circuit is given by:

$$L_{eff} = L_o(1 + g_m R) \quad (9)$$

The effective inductance  $L_{eff}$  given in (9) can be controlled electronically (voltage-controlled) by using a voltage-controlled transconductance  $g_m$ . This artificial voltage-controlled inductive reactance has similar advantages as that mentioned for the voltage-controlled capacitive reactance. One additional advantage of the proposed voltage-controlled inductive reactance is that large artificial inductors can be obtained from small inductors and this can solve some of the problems in RF chip design [3].

By using a circuit similar to that of Fig. 2 but with replacing the capacitors  $C_o$  and  $C_1$  by the inductors  $L_o$  and  $L_1$ , respectively, a voltage-controlled inductance with the capability of making the real part of the impedance zero or negative can be obtained. The input impedance of this modified circuit is found to be:

$$Z_i = (R - g_m X_{L_o} X_{L_1}) + j[X_{L_1} + X_{L_o}(1 + g_m R)] \quad (10)$$

The effective inductive reactance of this circuit is the same as that in (8) except for the additional fixed reactance of the capacitor  $L_1$ .

### III. PRACTICAL CIRCUITS AND SIMULATION RESULTS

Fig. 3 shows a practical circuit for the implementation of the voltage-controlled capacitance shown in Fig. 2 which has the inherent capability of producing negative resistance. If the negative resistance is not needed, the capacitor  $C_1$  has to be replaced by a DC blocking capacitor with very large value compared to  $C_o$ . The common collector BJT amplifier is used as a current source with a voltage-controlled transconductance. The transconductance is controlled by the bias voltage which is applied to the base of the transistor through the resistance  $R_B$ . The radio frequency choke (RFC) with its high impedance is used to divert the whole ac current of the current source through the capacitor  $C_o$ .

The AC equivalent for this circuit is shown in Fig. 4 where  $R_B$ ,  $R_E$ , and RFC are not shown in the circuit because of their relative high impedance. If  $(R - jX_{C_1})$  is much smaller than  $r_\pi$  and  $(-jX_{C_o})$  is much smaller than  $r_o$ , the equivalent circuit of Fig. 4 is reduced to that of Fig. 2 and therefore, the input impedance of the practical circuit is the same as that given by (7).

The voltage-controlled transconductance of this circuit can be easily found from its DC analysis and it is given by the following relation:

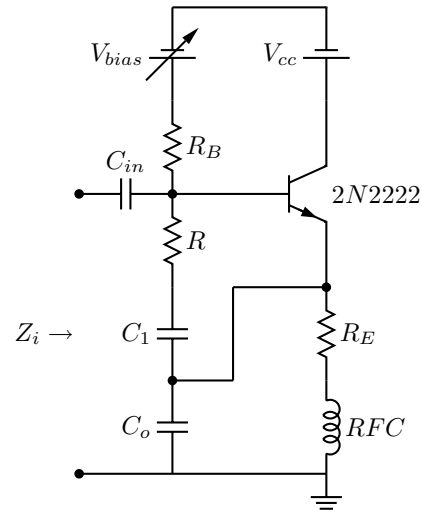

Fig. 3 A practical circuit for the artificial voltage-controlled capacitive reactance.

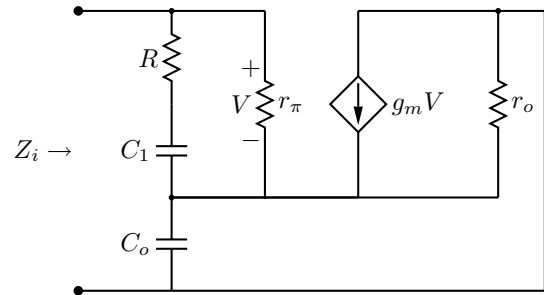

Fig. 4 The ac equivalent circuit for the circuit in Fig. 3

$$g_m = \frac{I_C}{V_T} = \frac{(V_{bias} - 0.7)}{(R_E + \frac{R_B}{\beta})V_T} \quad (11)$$

where  $V_T$  is the thermal voltage ( $V_T = \frac{kT}{e} = 0.026V$  at room temperature),  $\beta$  is the current gain of the transistor, and  $I_C$  is the DC collector current. The range over which the transconductance  $g_m$  can be varied is determined by the range of the bias voltage  $V_{bias}$  and the values of  $R_E$ ,  $R_B$  and  $\beta$  provided that the transistor will not enter the saturation region. It is obvious from (11) that the transconductance of the amplifier is a linear function of the bias voltage and hence the input capacitance reactance given by (7) is also a linear function of the bias voltage. The circuit of Fig. 3 can be converted to a voltage-controlled inductance by replacing the capacitors  $C_o$  and  $C_1$  by inductors  $L_o$  and  $L_1$ , respectively, provided blocking capacitors are inserted in the right places to prevent the inductors from short circuiting the DC bias of the transistor.

The circuit in Fig. 3 is simulated using the PSpice software with the following values for its components:  $R = 100\Omega$ ,  $R_E = 1K\Omega$ ,  $R_B = 100K\Omega$ ,  $C_o = C_1 = 1nF$ ,  $C_{in} = 10\mu F$  and  $L_{RFC} = 1mH$ . The simulated input resistance and input capacitive reactance for this circuit are plotted as function of the bias voltage for different frequencies as it is shown in Fig.5.

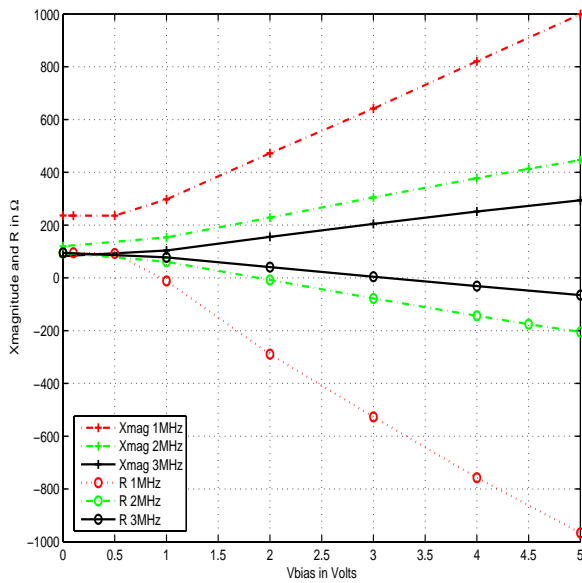

Fig. 5 The simulated input resistance and capacitive reactance for the circuit in Fig. 3.

It is obvious from Fig. 5, that except for the low bias voltage region where the transistor is in cutoff ( $V_{bias} < 0.6V$ ), the input capacitance reactance is linearly related to the control bias voltage and this is in full agreement with the relation given by (7). Since the transconductance  $g_m$  is linearly related to  $V_{bias}$ , the slope of the capacitive reactance curve is determined by the product ( $X_{C_o}R$ ) and it is inversely proportional to the frequency since  $X_{C_o} = \frac{1}{\omega C_o}$ . For a given frequency, the slope can be increased by lowering the value of the bias resistor  $R_B$  provided that the transistor will not enter the saturation region over the desired control voltage range. The maximum value of the artificial capacitive reactance is found from the simulation results to be six times larger than reactance of the fixed capacitor  $C_o$ . According to (7), the maximum amount of increase in the capacitive reactance is determined by the value of the factor  $(1 + g_m R)$ . Since the maximum value of  $g_m$  is limited by the power consumption of the circuit, the resistor  $R$  is used to control the maximum amount of increase in the capacitive reactance. But since larger values of  $R$  degrade the  $Q$  factor of the circuit, the negative resistance of this circuit is used to make the overall input resistance zero or negative. The input resistance of the circuit of Fig. 3 is shown in Fig. 5 at different frequencies and it has a negative value above certain threshold bias voltages which depend on the frequency i.e. 1V for 1 MHz, 2V for 2 MHz and 3V for 3 MHz. The reason behind the reduction of the negative resistance range at higher frequencies is the reduction in the magnitude of the negative resistance term ( $g_m X_{C_o} X_{C_1}$ ) in (7) since the capacitive reactance decreases with increasing the frequency. But by choosing the proper values of  $C_o$  and  $C_1$ , the voltage-controlled capacitance or inductance reactance with the necessary negative resistance can be set to work anywhere in the frequency spectrum for the different applications provided a current source with a

voltage-controlled transconductance is available in that region of the spectrum. The circuit of Fig. 3 can be easily modified to work as an artificial voltage-controlled inductance reactance by replacing  $C_o$  and  $C_1$  by  $L_o$  and  $L_1$  and similar simulation results are expected.

#### IV. CONCLUSION

In this paper, we proposed a new technique by which an artificial voltage-controlled capacitive or inductive reactance can be obtained. The proposed device has many advantages over the varactor diode such as a wide range of tuning and a linear relation between the reactance and the bias voltage. Moreover, the proposed devices can set to work at any frequency in the frequency spectrum. Simulation results of practical circuits show a full agreement with the theoretical analysis.

#### REFERENCES

- [1] K. R. Thrower, "History of tuning," IEE International Conference on 100 Years of radio, September, 1995.
- [2] L. J. Giacoletto, and J. O'Connel, "A variable capacitance germanium junction diode for UHF," RCA Review, vol. 17, March, 1956, pp. 68-85.
- [3] B. Razavi, "Challenges in the design of frequency Synthesizers for Wireless Application," in Proc. IEEE CICC '97, May, 1997, pp. 395-402.
- [4] K. Stadius, R. Kaunisto, and V. Porra, "A High frequency harmonic VCO with an Artificial Varactor," in Proc. 5<sup>th</sup> ICECS '98, vol. 3, September, 1998, pp. 161-164.
- [5] K. Stadius, R. Kaunisto, and V. Porra, "Varactor diodeless harmonic VCOs for GHz-range applications," Analog Integrated Circuits and Signal Processing, Vol. 27, Issue 1-2, April/May 2001.
- [6] W. Z. Chen, J. T. Wu, "A 2-V 2-GHz BJT variable frequency oscillator," IEEE JSSC, vol. 33, no. 9, 1998, pp. 1406-1410.