

# Tuning of PV Array Layout Configurations for Maximum Power Delivery

Hadj Bourdoucen , Adel Gastli

**Abstract**—In this paper, an approach for finding optimized layouts for connecting PV units delivering maximum array output power is suggested. The approach is based on considering the different varying parameters of PV units that might be extracted from a general two-diode model. These are mainly, solar irradiation, reverse saturation currents, ideality factors, series and shunt resistances in addition to operating temperature. The approach has been tested on 19 possible  $2 \times 3$  configurations and allowed to determine the optimized configurations as well as examine the effects of the different units' parameters on the maximum output power. Thus, using this approach, standard arrays with  $n \times m$  units can be configured for maximum generated power and allows designing PV based systems having reduced surfaces to fit specific required power, as it is the case for solar cars and other mobile systems.

**Keywords**—Photovoltaic, PV unit, optimum configuration, maximum power, Orcad.

## I. INTRODUCTION

PHOTOVOLTAIC (PV) systems are widely used in different applications for their many advantages as they provide clean energy sources and also for their competitive costs in many remote sites as well as in mobile applications. With the progressive reduction in their fabrication costs, PV systems are currently knowing tremendous increase in different applications [1], [2]. The maximum efficiency of utilization of solar panels is obtained at the maximum power operating point, which is a function of the panel physical characteristics, solar irradiation, and temperature. To design a PV-based system, an accurate model of the panel is often required. Some PV cell and panel equivalent circuit approximations based on a single-diode model have been studied [3]-[7]. However, the simple models presented give acceptable results only for single crystalline cells. However, for some cost effective materials, the model presented is not accurate enough and the use of two-diode model gives better results [5]. In addition to this, a precise determination of the internal physical parameters of cells and panels is not always possible and the different errors introduced on all the parameters during the extraction process induce non negligible errors in the models of the PV units. In addition to this, the different modules mounted using different cells will not therefore have the same physical parameters which will

affect the efficiency of the module and hence the array output power. Furthermore, the effects of increasing temperature will further reduce the output power. Some tentatives have been presented in the literature to address the problem of the array layout configuration however the problem has been only partially analyzed. For instance, the authors of reference [12] concentrated on the maximum voltage, average voltage and current or maximum current as they directed this parameter to acceleration of a solar car. In the paper of reference [11], the problem was focused on only one parameter, which is temperature, and the authors presented a simple analysis approach of two simple cases of cells connected in series, and two others connected in parallel. The conclusions presented in the two papers are not amenable to be generalized to more complex PV layouts' configurations.

In this paper, an approach to finding the optimized configuration layout of PV panels is presented to determine the best configuration which gives maximum array output power. The approach is based on finding all possible PV array layout configurations for an  $n \times m$  cells/panels layout. These configurations are first analyzed then the layouts which give the maximum power output are then determined. As the selected  $n \times m$  cells/panels will be used anyway to construct the array, the approach identifies the best configuration layout to produce from these cells/panels the maximum output power. The idea is based on using a two-diode model for each unit, weather it is a cell or a panel, or even a module. ORCAD software program is used to simulate the different possible layouts and determine the layout which gives the maximum output power. To demonstrate the feasibility and efficiency of the suggested approach, a sample layout of 6 units of dimension  $n \times m$  cells/panels having different physical parameters has been considered.

It is worth noting that an experimental attempt connecting solar cells based on their powers to form panels has been conducted and it was demonstrated that performance of panel is improved using screened cells compared to panels obtained with randomly selected cells. However, there was no approach developed to deal with general layouts for connecting cells and panels to obtain best layouts providing maximum output power [6], [14]. The approach considered in this paper addresses this problem and deals with obtaining the optimized layouts' connection of solar array with no need for screening to generate the maximum output power from a set of solar

H. Bourdoucen and A. Gastli are with the Electrical and Computer Engineering Department, College of Engineering, Sultan Qaboos University, P.O. Box 33, Al-Khod, Muscat 123, Sultanate of Oman (corresponding author e-mail: hadj@squ.edu.om).

cells. This will therefore minimize the surface to be covered by the solar units as the power to be generated will be maximized. This is the case for solar cars and many other PV-based systems where the amount of surface needed is of main concern.

II. MATHEMATICAL MODELING

A PV array is composed of a connection of units or modules to deliver a given output power. The PV modules existing in the market have typical output power characteristics within certain rated values. However, the slight differences in their physical and design characteristics might induce not negligible changes in the output power of the array if a non-optimal configuration layout is adopted. This can also become critically important in PV systems where the available area of the array is of major concern. This is mostly the case in solar cars and in many other mobile PV systems including satellites and some telecommunication stations.

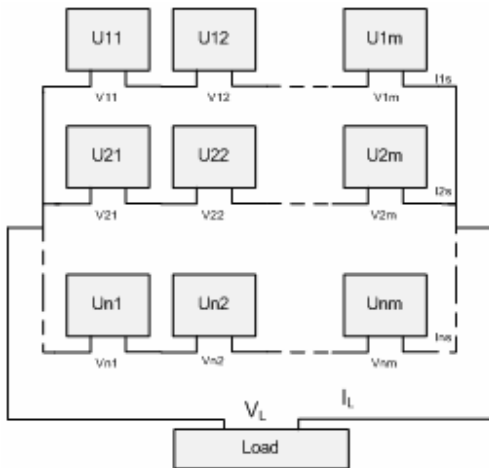

Fig. 1 General layout of a PV array constructed from U<sub>ij</sub> modules to be optimized for maximum output power.

The model presented hereafter is based on a typical layout of an  $n \times m$  PV array where  $n$  is the number of units in a given row (connected in parallel) and  $m$  is the number of units in a given column (connected in series). Figure 1, shows a standard configuration which can be used to construct any other desired shape such as L, U or T layout configuration. The PV units (modules) U<sub>ij</sub> are supposed to have at least one physical parameter different from each other. Each unit is modeled using the circuit shown in figure 3. More details on this model is given in a subsequent section. With reference to the array layout of figure. 1, the units U<sub>11</sub>, U<sub>12</sub>, ..., U<sub>1m</sub> connected in series will have the same current going through them represented by I<sub>1s</sub>. The same approach is valid for the second row constituted of modules, U<sub>21</sub>, U<sub>22</sub>, ..., U<sub>2m</sub>, as well as for the last row of modules, U<sub>n1</sub>, U<sub>n2</sub>, ..., U<sub>nm</sub> where the currents are respectively I<sub>2s</sub>, ..., I<sub>ns</sub>. The following sets of

voltage equations can be written for the modules placed at the different rows 1 to  $n$  as,

$$\begin{cases} V_{11} + V_{12} + \dots + V_{1m} = V_{1s} \\ V_{21} + V_{22} + \dots + V_{2m} = V_{2s} \\ \dots \\ V_{n1} + V_{n2} + \dots + V_{nm} = V_{ns} \end{cases} \quad (1)$$

Since all these modules are connected in parallel, it comes out that,

$$V_{1s} = V_{2s} = \dots = V_{ns} = V_L \quad (2)$$

The equations of the currents for the modules U<sub>11</sub> to U<sub>nm</sub>, can be expressed in the same way as:

$$\begin{cases} I_{11} = I_{12} = \dots = I_{1m} = I_{1s} \\ I_{21} = I_{22} = \dots = I_{2m} = I_{2s} \\ \dots \\ I_{n1} = I_{n2} = \dots = I_{nm} = I_{ns} \end{cases} \quad (3)$$

The total current, which is the load current I<sub>L</sub>, generated by all these modules is expressed as

$$I_L = I_{1s} + I_{2s} + \dots + I_{ns} \quad (4)$$

Thus, the power delivered to the load can be expressed by the following relation

$$P_L = I_L \times V_L = \sum_{j=1}^m I_{nj} \times (V_{1s} \text{ or } V_{2s} \dots \text{ or } V_{ns}) \quad (5)$$

Considering the array formed by  $n \times m$  units as shown on figure. 1, it is desired to find the best layouts which give maximum output power using the same units numbered U<sub>11</sub>, ... to U<sub>nm</sub>. This means that each module of the  $n \times m$  units needs to be placed at the right locations to contribute efficiently to deliver the array maximum output power.

A direct approach is to consider finding all possible layout connections that might be generated using these  $n \times m$  units to build a typical panel layout. For instance, the general layout configuration of figure. 1, composed of  $m$  units in series and  $n$  in parallel, the total number of units is  $N = n \times m$  to be arranged in different layouts. It is worth noting that the total number of possible connections needs to be reduced by  $(n-1)!$  combinations as the parallel connections do not depend on the order of the  $n$  parallel units. The total number  $N_L$  of possible different layouts to connect the  $n \times m$  units can be determined by the following expression:

$$N_L = \frac{(n \times m)!}{(n \times m - m) \times m!} - (n-1)! = \frac{(N)!}{(N-m) \times m!} - (n-1)! \quad (6)$$

Where,  $n=1,2,\dots$  and  $m=1, 2,\dots$

For instance, if the considered PV array is composed of 6 units to be connected as a  $2 \times 3$  matrix as shown in figure. 2, the total number of possible layouts using equation (6) turns

out to be 19. A tabular representation of all the different layout connections is shown in figure. 2, where  $C_k$  is the unit number  $k$  placed as shown. Note that  $k=1, 2, 3, \dots, N_L$ . The objective is to find which configuration of these  $N_L$  layouts is delivering the maximum output power.

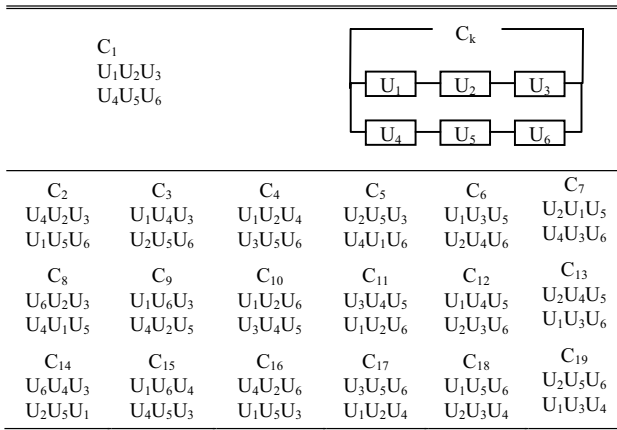

Fig. 2 All possible configurations  $C_k$ , corresponding to  $k=1, 2, \dots, N_L=19$ , constructed from units  $U_1, \dots, U_6$  considering arrays of  $2 \times 3$  units.

Each PV module  $U_{ij}$  may be described in terms of a set of electric parameters that represent its physical properties. Most of solar cell models available in the literature represent the cell by a single diode in parallel with a current source. However, in order to have more generalized model and obtain improved accuracy in the simulation results, the two-diode equivalent circuit model shown in figure 3 has been adopted [5]-[7].

Note that the shunt and series resistances are two important parameters in PV modules. This is because the shunt resistance mostly affects the module output power and the series resistance affects the efficiency and the fill factor [4], [8].

With reference to figure 3, and in connection to the array layout of figure. 1, the current  $I_{ij}$  of the unit  $U_{ij}$  can be expressed as,

$$I_{ij} = I_{phij} - I_{D1ij} - I_{D2ij} - I_{shij} \tag{7}$$

These current components above will be expressed by equations (9)-(12) below, where,  $R_{Sij}$  and  $R_{SHij}$  are the series and shunt resistances respectively,  $I_{SD1ij}$  and  $I_{SD2ij}$  are diffusion and saturation currents respectively,  $n_{1ij}$  and  $n_{2ij}$  are the diffusion and recombination diode ideality factors,  $k$  is the Boltzman's constant,  $q$  is the electronic charge,  $T_{ij}$  is temperature in Kelvin,  $C_{0ij}$  and  $C_{1ij}$  are constants, and  $G_{ij}$  is the irradiation in  $W/m^2$ .

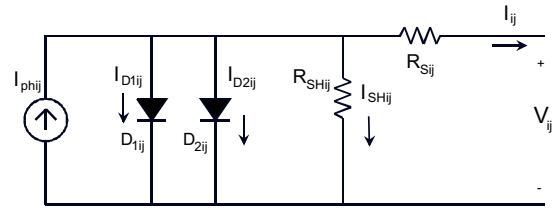

Fig. 3 Electric model for PV module based on two-diode approach

Based on the models developed elsewhere [3]-[5] and by taking into account the change of  $R_{Sij}$  and  $R_{SHij}$  from one cell/panel to another, an improved panel model was proposed [9]. The expressions to be used for the model together with (7) are given in (9)-(12) below. Typical figures for changes on the above two parameters have been suggested and their effects were studied by simulation using Matlab/Simulink software [9].

Note that the formulation presented below with regard to changes induced on the units' physical parameters is supported by practical considerations where these values are affected by the way external connections of modules are done as well as by aging time of the array. Following on the formulation presented in [9], the expressions of the different current components of equation (7) are expressed as follows for every PV unit  $U_{ij}$

$$I_{D1ij} = I_{S1ij}(T) \left[ \exp\left(\frac{q}{n_{1ij}kT_{ij}}(V_{ij} - I_{ij}R_{Sij})\right) - 1 \right] \tag{8}$$

$$I_{D2ij} = I_{S2ij}(T) \left[ \exp\left(\frac{q}{n_{2ij}kT_{ij}}(V_{ij} - I_{ij}R_{Sij})\right) - 1 \right] \tag{9}$$

$$I_{shij} = \frac{V_{ij} - I_{ij}R_{Sij}}{R_{SHij}} \tag{10}$$

$$I_{phij} = (C_{0ij} + C_{1ij}T) \times G_{ij} \tag{11}$$

Note also that  $R_{Sij}$  and  $R_{SHij}$  are supposed to vary with both solar irradiance and temperature. A formulation of this dependency can be found in [10].

Expressions (8) to (11) are included in (7) to give the following equation which governs the output I-V characteristics of any module  $U_{ij}$  as indicated in figure 2. Hence,

$$I_{ij} = (C_{0ij} + C_{1ij}T) \times G_{ij} - I_{S1ij}(T) \left[ \exp\left(\frac{q}{n_{1ij}kT_{ij}}(V_{ij} - I_{ij}R_{Sij})\right) - 1 \right] - I_{S2ij}(T) \left[ \exp\left(\frac{q}{n_{2ij}kT_{ij}}(V_{ij} - I_{ij}R_{Sij})\right) - 1 \right] - \frac{V_{ij} - I_{ij}R_{Sij}}{R_{SHij}} \tag{12}$$

This equation has to be considered in simulation for every module  $U_{ij}$  to solve the system of equations (5). It is important to note that this is a nonlinear system to be solved for the output load power  $P_L$ . To benefit from the optimized solving tools available in Orcad / Spice, the system has been solved for a set of typical array layouts as indicated above.

Some simplifying assumptions might always be thought of to minimize the number of cases to be computed, as this will affect the simulation time and memory requirements and may rise some convergence problems for some critical connection layouts.

However, with the existing speed and memory available in current computing machines, this issue will be of minor concern. For instance, the total simulation time to compute all the 19 layouts above was less than 1.50 seconds for OrCad ver. 9.2. This will assure fast reconfiguration of PV array layout in response to any parameter change.

TABLE I  
TYPICAL BOUNDARY VALUES FOR THE SEVEN PHYSICAL PARAMETERS OF A PV UNIT

Variable	Typical value	Minimum Value	Maximum Value	Step Change
$I_{ph}$ (A)	1.64	1.09	2.19	$2.20 \times 10^{-1}$
$n_1$	0.95	0.90	1.00	$2.00 \times 10^{-2}$
$n_2$	1.90	1.80	2.00	$4.00 \times 10^{-2}$
$I_{s1}$ (A)	$6.2 \times 10^{-9}$	$4.80 \times 10^{-10}$	$1.20 \times 10^{-8}$	$2.30 \times 10^{-9}$
$I_{s2}$ (A)	$1.30 \times 10^{-4}$	$1.00 \times 10^{-5}$	$2.50 \times 10^{-4}$	$4.80 \times 10^{-5}$
$R_{sh}$ ( $\Omega$ )	200	100	300	40.0
$R_s$ ( $\Omega$ )	$3.0 \times 10^{-2}$	$1.00 \times 10^{-2}$	$5.00 \times 10^{-2}$	$8.00 \times 10^{-3}$

TABLE II  
PHYSICAL VALUES USED FOR THE DIFFERENT PARAMETERS OF SIX UNITS U1 TO U6, DETERMINED FROM THE CONSTRAINTS INDICATED ON TABLE I

Variable / Unit	U <sub>1</sub>	U <sub>2</sub>	U <sub>3</sub>	U <sub>4</sub>	U <sub>5</sub>	U <sub>6</sub>
$I_{ph}$ (A)	1.09	1.31	1.53	1.75	1.97	2.19
$n_1$	0.90	0.92	0.94	0.96	0.98	1.00
$n_2$	1.80	1.84	1.88	1.92	1.96	2.00
$I_{s1}$ (A)	$4.8 \times 10^{-10}$	$2.78 \times 10^{-9}$	$5.09 \times 10^{-9}$	$7.39 \times 10^{-9}$	$9.70 \times 10^{-9}$	$1.20 \times 10^{-8}$
$I_{s2}$ (A)	$1.0 \times 10^{-5}$	$5.8 \times 10^{-5}$	$1.06 \times 10^{-4}$	$1.54 \times 10^{-4}$	$2.02 \times 10^{-4}$	$2.50 \times 10^{-4}$
$R_{sh}$ ( $\Omega$ )	100	140	180	220	260	300
$R_s$ ( $\Omega$ )	$1.00 \times 10^{-2}$	$1.80 \times 10^{-2}$	$2.60 \times 10^{-2}$	$3.40 \times 10^{-2}$	$4.20 \times 10^{-2}$	$5.00 \times 10^{-2}$

The parameters of the six PV units considered U<sub>1</sub> to U<sub>6</sub> are given in Table 2. These values of  $I_{ph}$ ,  $n_1$ ,  $n_2$ ,  $I_{s1}$ ,  $I_{s2}$ ,  $R_{sh}$  and  $R_s$  in addition to temperature were generated based on a uniform linear interpolation scheme from the boundary typical values indicated on Table 1.

### III. SIMULATION RESULTS

All nineteen configurations have been simulated with OrCAD software with temperature  $T$  that varies from 27, 40, 60 and 80 °C and irradiation  $G$  kept constant.

Note that a Spice model has been generated for every unit of the six units based on the expressions (8)-(11) indicated above.

It is also worth noting that typical values of the constants  $C_0$  and  $C_1$  were taken from reference [6]. These are  $C_0=4.38 \times 10^{-3}$  A.m<sup>2</sup>/W,  $C_1=0$  A.m<sup>2</sup>/W.K. On the other hand, the load resistance is kept variable to determine the output power profile and hence determine for every unit the maximum power that can be delivered.

Both voltage and current at the load of the array are determined and the maximum power operating point is calculated from the I-V characteristic which is given by,

$$P_{max|k} = \max\{V \times I\}|_k = (V_{opt} \times I_{opt})|_k \quad (13)$$

Where,  $V_{opt}$  and  $I_{opt}$  are respectively the optimum operating point voltage and current for the unit  $k$ .

The nineteen different layout configurations have been simulated using OrCad and the results of the maximum power for each unit at different temperatures are shown in figure. 4. One can see from this figure that for the considered units' arrangement, the maximum power is fluctuating between low and high values. This trend is valid for the range of temperatures varying from 27 to 80 degree Celsius.

The top highest maximum power of the units is obtained for U<sub>1</sub> where all the values of the seven above parameters have minimum values (refer to Table 1). For instance the curve at 27°C have elevated powers for the configurations C<sub>1</sub>, C<sub>17</sub>, C<sub>4</sub>, C<sub>14</sub>, C<sub>7</sub>, C<sub>11</sub>, C<sub>10</sub>, with power values changing from 2.5074 W to 2.4524 W. However, low powers occur for configurations C<sub>2</sub>, C<sub>18</sub>, C<sub>5</sub>, C<sub>15</sub>, C<sub>8</sub>, C<sub>12</sub>, with power changing from 2.387 W to 2.384 W. This trend is observed for the three other higher temperatures, i.e., 40, 60 and 80°C. It appears from the above observations that there is no clear trend on how to classify the units having maximum power output when the seven above parameters are all changing.

For instance configuration C<sub>1</sub> giving maximum power and configuration C<sub>2</sub> with minimum power are obtained by just swapping units 1 and 6, where unit 1 has minimum values of all seven parameters and unit 6 has maximum values. As for the other combinations the trend becomes more complex as the system is highly non linear. It is why in the absence of any simplifying assumptions, the proposed approach needs to be used to determine the best configurations, which gives maximum output power.

Figure 5, shows the percentage change in maximum output power for all the different layouts, U<sub>1</sub> to U<sub>19</sub> at the four temperatures indicated above.

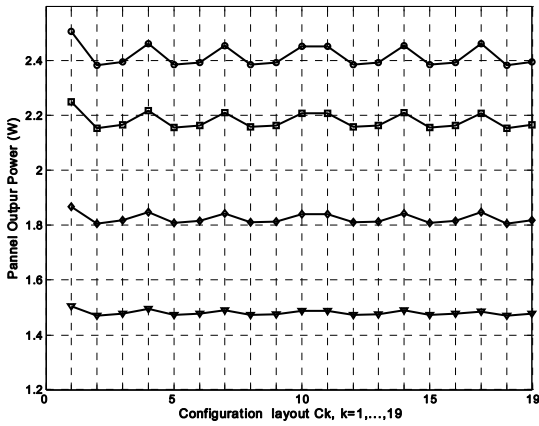

Fig. 4 Maximum output power for all possible units,  $U_1$  to  $U_{19}$  at temperatures 27, 40, 60 and 80°C designated by the symbols: o, □, ◇ and ∇ respectively.

Note from this figure that for the considered layouts and given parameters, the change in delivered maximum power can exceed 5%. This figure might increase considerably for configurations with higher number of units.

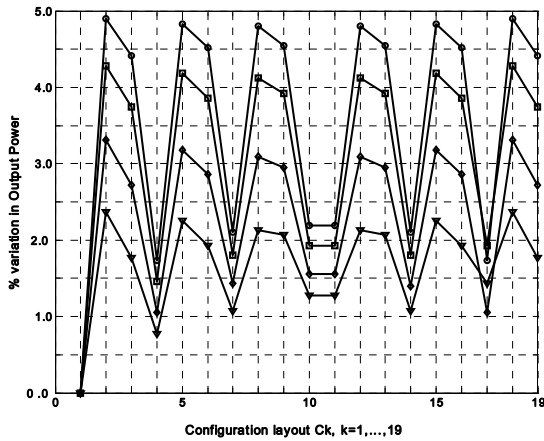

Fig. 5 Percentage change in maximum output power for all layouts,  $U_1$  to  $U_{19}$  at temperatures, 27, 40, 60 and 80°C designated by the symbols: o, □, ◇ and ∇ respectively.

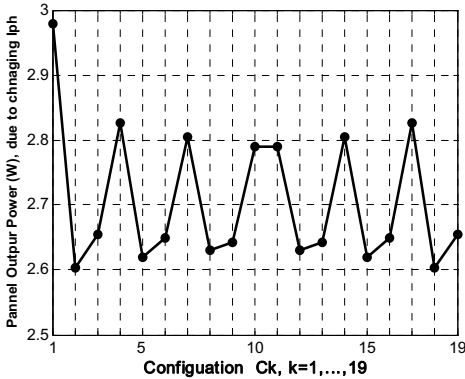

Fig. 6 Variation of panel output power for all layouts,  $U_1$  to  $U_{19}$  due to changing  $I_{PH}$  from 1.09A to 2.19A for a temperature of 27°C

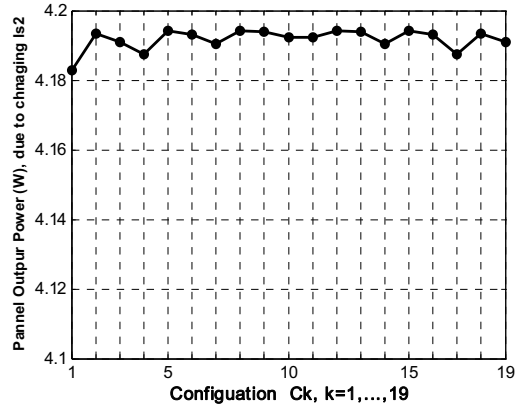

Fig. 7 Variation of panel output power for all layouts,  $U_1$  to  $U_{19}$  due to changing  $I_{S_2}$  from  $10^{-5}$  A to  $2.5 \times 10^{-4}$  A for a temperature of 27°C

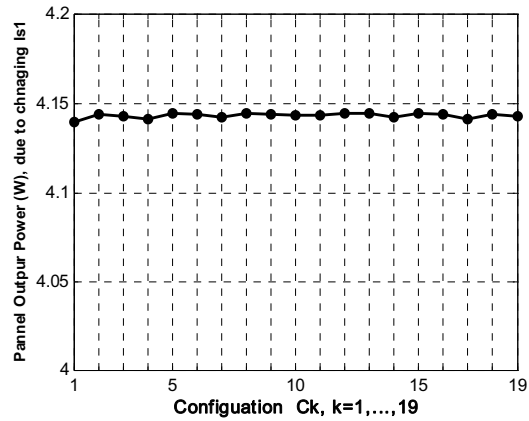

Fig. 8 Variation of panel output power for all layouts,  $U_1$  to  $U_{19}$  due to changing  $I_{S_1}$  from  $4.8 \times 10^{-10}$  A to  $1.2 \times 10^{-8}$  A for a temperature of 27°C.

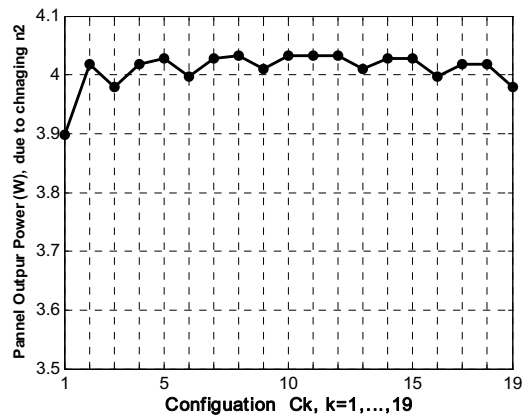

Fig. 9 Variation of panel output power for all layouts,  $U_1$  to  $U_{19}$  due to changing  $n_2$  from 1.8 to 2.0 for a temperature of 27°C

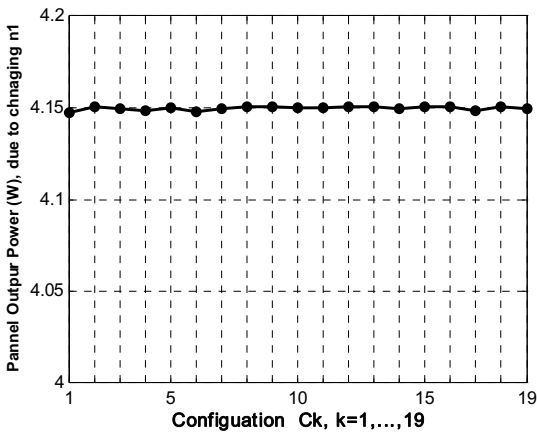

Fig. 10 Variation of panel output power for all layouts,  $U_1$  to  $U_{19}$  due to changing  $n_1$  from 0.9 to 1.0 for a temperature of 27°C

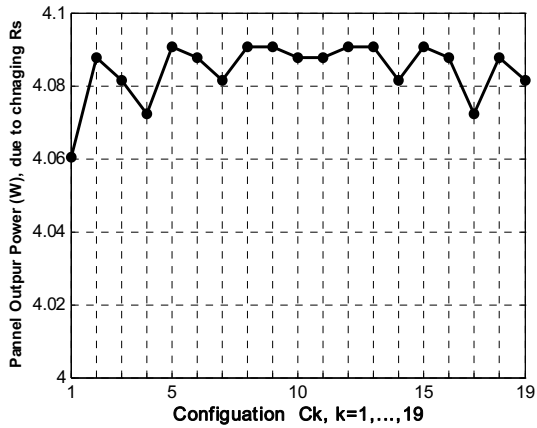

Fig. 11 Variation of panel output power for all layouts,  $U_1$  to  $U_{19}$  due to changing of series resistance  $R_s$  from 0.01Ω to 0.05Ω for a temperature of 27°C

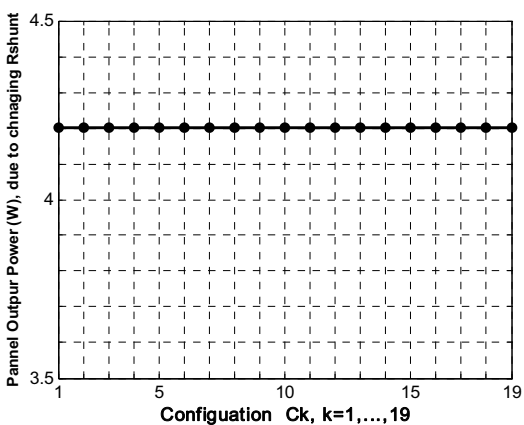

Fig. 12 Variation of panel output power for all layouts,  $U_1$  to  $U_{19}$  due to changing shunt resistance  $R_{SH}$  from 100Ω to 300Ω for a temperature of 27°C.

It is worth noting that if all the units  $U_1$  to  $U_{19}$  are equivalent and have the same typical parameters values as indicate in Table 1, the output power of the panel is 4.2012 W. The maximum output power that can be obtained from the configuration shown in Figure 4, where all the units' parameters are changing, is less by more than 40% of this value. In order to examine which parameters of the units have more significant effects on this drop, a set of simulations have been performed. These consist of varying one parameter at a time among the seven totals for the six units.

The simulation results of the nineteen possible configurations are show in figures, 6 to 12 configurations. Figure 6 shows the Variations of the output power for all layouts,  $U_1$  to  $U_{19}$  due to changing  $I_{PH}$  from 1.09A to 2.19A at a temperature of 27°C. It appears from this figure the significant effect of illumination on the output power. The highest power output is obtained for configuration 1 where the cells are connected in ascending order with regards to  $I_{PH}$  values.

Figures, 8, 10 and 12 show the variations of output power for all layouts,  $U_1$  to  $U_{19}$  due to changing respectively,  $I_{S1}$ ,  $n_1$  and  $R_{SH}$ . Note the very insignificant effect of these three parameters on the layout configuration. However, a relatively more significant effect of the parameters  $I_{S2}$ ,  $n_2$  and  $R_s$  is noticed respectively in Figures 7, 9 and 11. The above observations apply for the configuration considered and might be extended to more complex ones presented here may constitute the basic building bloc for more complex configurations.

Some typical case studies on how to connect solar cell units based on their main physical and environmental parameters namely, solar irradiations, temperatures, series resistances, or shunt resistances to obtain maximum power have been investigated using Matlab in reference [13]. This has bee done in case where the parameters,  $n_1$ ,  $n_2$ ,  $I_{s1}$  and  $I_{s2}$  are assumed to remaining unchanged for all the units.

#### IV. CONCLUSION

An approach for finding the number and optimized layouts for connecting PV units for maximum array output power was presented. It uses the different varying parameters of a PV unit that can be extracted from a general two-diode model. These are, solar irradiation, reverse saturation currents, ideality factors, series and shunt resistances. The approach has been tested by simulation of 2x3 units using OrCAD and the results show that internal as well as external parameters of PV units affect the maximum output power generated by the array. These also show that the main factor that affects the output power is the photocurrent that is directly dependent on solar irradiation and the least affecting factor is the shunt resistance. Therefore, finding the best connection configurations is very important in obtaining the maximum power and thus reducing the surface used which is of critical importance in several mobile PV based systems.

The proposed approach appears to be efficient, simple, can be generalized to more complex layouts and may be used for wide-spread applications of PV systems.

#### REFERENCES

- [1] 2006 IEEE 4th World Conference on Photovoltaic Energy Conversion, Hilton Waikoloa Village, Waikoloa, Hawaii, May 7-12, 2006.
- [2] R. L. Mitchell, C. E. Witt, R. King, and D. Ruby, "PVMaT advances in the photovoltaic industry and the focus of future PV manufacturing R&D", 29th IEEE Photovoltaic Specialists Conference, 19-24 May pp. 1444 – 1447, 2002.
- [3] Z. Ouennoughi, and M. Cheggar, "A simpler method for extracting solar cell parameters using the conductance method", *Solid-State Electronics* 43, pp. 1985-1988, 1999.
- [4] J. I. Lee, J. Brini, and C. A. Dimitriadis, "Simple parameter extraction method for non-ideal Schottky barrier diodes", *Electronics Letters* 34, 12, pp. 1268-1269, 1998.
- [5] F. Araujo, E. Sanchez, and M. Marti, "Determination of the two-exponential solar cell equation parameters from empirical data", *Solar Cells* 5, pp. 199-204, 1982.
- [6] R. Gottschalg, M. Rommel, D.G. Infield, and M.J. Kearney, "The influence of the measurement environment on the accuracy of the extraction of the physical parameters of solar cells". *Journal Meas. Sci. Technol.* 10, pp. 797-804, 1999.
- [7] A. Kaminski, J.J. Marchand, A. Fave, and A. Laugier, New method of parameters extraction from dark I-V curve. 26th PVSC, (Anaheim, CA, Sept. 30 - Oct. 3, pp. 203-205, 1997.
- [8] T. J. McMahon, T. S. Bosso, and S. R. Rummel, Cell shunt resistance and photovoltaic module performance. 25th PVSC, (Washington D.C., May 13-17, pp. 1291-1294, 1996.
- [9] H. Bourdoucen and A. Gastli, "Analytical Modelling and Simulation of Photovoltaic Panels and Arrays", *The Journal of Engineering Research*, Vol.4, No.1, pp. 75-811, 2007.
- [10] N. Veissid, A. M. De-Andrade, The I-V silicon solar cell characteristics parameters temperature dependence, an experimental study using the standard deviation method. 10th PSEC, Portugal, pp. 43-49, 1991.
- [11] K. Reiche, R. Preu, G.Kleiss, K. Bucher, "Effects of Advantageous Placing of PVCells and Modules In Generating units", *First WCPEC*; Hawaii, Dec. 5-9, 1994.
- [12] Yingrak Attawaitkul, Boonnua Pungsiri, Kosin Chammongthai, and Makoto Okuda, "A Method of appropriate Electrical Array Reconfiguration Management for Photovoltaic Powered Car", *Circuits and Systems*, 1998. IEEE Asia-Pacific Conference on APCCAS, pp 201-204, 1998..
- [13] A. Gastli and H. Bourdoucen, "Study and Modelling of PV Arrays Built with Non- Equivalent Units", *Proceeding of the International Conference on Communication, Computer and Power (ICCCP'07)*, Muscat, Oman, February 19-21, pp. 186-191, 2007.
- [14] J. Appelbaum, and T. Segalov, "Screening Solar Cells for Improved Array Performance", *Progress in Photovoltaic*, Vol. 7, pp. 113-128, 1999.