

# Fault Classification of Double Circuit Transmission Line Using Artificial Neural Network

Anamika Jain, A. S. Thoke, and R. N. Patel

**Abstract**—This paper addresses the problems encountered by conventional distance relays when protecting double-circuit transmission lines. The problems arise principally as a result of the mutual coupling between the two circuits under different fault conditions; this mutual coupling is highly nonlinear in nature. An adaptive protection scheme is proposed for such lines based on application of artificial neural network (ANN). ANN has the ability to classify the nonlinear relationship between measured signals by identifying different patterns of the associated signals. One of the key points of the present work is that only current signals measured at local end have been used to detect and classify the faults in the double circuit transmission line with double end infeed. The adaptive protection scheme is tested under a specific fault type, but varying fault location, fault resistance, fault inception angle and with remote end infeed. An improved performance is experienced once the neural network is trained adequately, which performs precisely when faced with different system parameters and conditions. The entire test results clearly show that the fault is detected and classified within a quarter cycle; thus the proposed adaptive protection technique is well suited for double circuit transmission line fault detection & classification. Results of performance studies show that the proposed neural network-based module can improve the performance of conventional fault selection algorithms.

**Keywords**—Double circuit transmission line, Fault detection & classification, High impedance fault and Artificial Neural Network.

## I. INTRODUCTION

DOUBLE circuit transmission lines are being used more widespread as they increase the power transmission capacity and increase the reliability of the system. However, there is difficulty in classifying the fault types on such lines using conventional techniques, principally because a faulted phase(s) on one circuit has an effect on the phases of the healthy circuit due to mutual coupling between the two circuits. The positive and negative sequence coupling between the two feeders is usually less than 5–7 % and, hence, has negligible effect on protection. However the zero sequence coupling can be strong and its effect cannot be ignored. The

mutual impedance can be as high as 50–70% of the self-impedance. Thus mutual coupling particularly under earth faults, poses difficulties for conventional distance protection schemes. One principal cause is the presence of fault resistance which, depending upon the level of mutual coupling and/or source impedance, can cause the protection relay to either overreach or underreach. The problem is compounded by the remote source infeed to the faulted branch. Similarly, substantial errors in measurement can result from ignoring the capacitance influence especially for high resistance faults. The problem is compounded by the fact that this coupling is not constant in nature and is dependent upon a complex interplay amongst a number of variables. As a consequence, the coupled phase(s) on the healthy circuit may sometimes be wrongly diagnosed as being the faulted phase. It should be noted that the aforementioned problems are particularly endemic when there is earth fault in a fault. In this respect, the vast majority of faults (over 90%) are of the single-phase-earth type. The conventional classifiers based on logical comparison techniques or linear algorithms are not well suited for such circuits. Thus, it is vitally important to develop an alternative protection scheme, such as that based on the adaptive concept, for such systems. Very often, fault classification is part of an overall protection scheme. To a large extent, the majority of power system protection techniques are involved in defining the equipment states through identifying the pattern of the associated voltages and/or currents. This effectively means that the development of adaptive protection can be essentially treated as a problem of pattern recognition of the Artificial Neural Network. The conventional pattern recognition techniques find it difficult to map complex and highly nonlinear input–output patterns associated with faults on double-circuit lines due to the changing system conditions and many causes of faults.

ANN is powerful in pattern recognition, classification and generalization. Consequently, various ANN-based algorithms have been investigated and implemented in power systems in recent years [1]. Neural Networks are useful for power system applications because they can be trained with off-line data. The specialty of ANN based distance protection is that it does not explicitly use the impedance information as the basis of information rather it learns from the examples presented to it during training. ANNs possess excellent features such as generalization capability, noise immunity, robustness and fault tolerance. Therefore, the decision made by an ANN-based relay will not be seriously affected by variations in system parameters. ANN-based techniques have been used in power

Manuscript received June 3, 2008.

Anamika Jain is working as Assistant Engineer in the Chhattisgarh State Electricity Board, Dangania, Raipur, C.G., India (e-mail: anamika\_jugnu@yahoo.com).

A.S. Thoke is with the Department of Electrical Engineering, N.I.T. Raipur, C.G., India, (e-mail: asthoke@yahoo.co.in).

R. N. Patel is with the Department of Electrical and Electronics Engineering, SSCET, Bhillai, C.G., India, (e-mail: ramnpatel@gmail.com).

system protection and promising results are obtained as a basic relaying tool & as an alternative to existing schemes [2-10].

In this paper, we present an extension to neural network based transmission line fault detection and classification technique reported in [2] for single circuit transmission line to double circuit transmission line and propose an adaptive protection scheme for such systems by using the ANN approach. Based on the authors' comprehensive digital simulation models of the double-circuit transmission systems, particular emphasis is placed on data preprocessing for feature extraction used as inputs to the ANN. The pattern classifier, i.e. the protection technique, is tested for one fault type but under different fault locations, fault resistances, fault inception angles and remote-end infeed. A combined 220 kV double-circuit line configuration is simulated using MATLAB® software.

II. POWER SYSTEM NETWORK SIMULATION

A. The system studied

The system studied is composed of 220KV double-circuit transmission lines, 100 km in length, connected to a source at each end, as shown in Fig. 1. All components are modelled by the MATLAB® Simulink & SimPowerSystem toolbox. Short circuit capacity of the equivalent Thevenin sources on two sides of the line is considered to be 1.25 GVA. Source to line impedance ratio is 0.5 and X/R is 10. The transmission line is simulated using distributed parameter line model. Various double circuit transmission line parameters are shown in Table-I

B. Typical primary system waveforms

Fig. 2 typifies the voltage and current waveforms when an 'A1'-phase to earth fault occurs at 30 KM from end S on circuit 1 of the configuration shown in Fig. 1 at 60 ms with zero fault resistance and 0 degree fault inception angle. As expected, a current is also induced in the 'A2'-phase of healthy circuit 2 due to the mutual coupling between the two circuits.

TABLE I  
DOUBLE CIRCUIT LINE PARAMETERS

Positive sequence resistance R1, Ω/KM	0.01809
Zero sequence resistance R0, Ω/KM	0.2188
Zero sequence mutual resistance R0m, Ω/KM	0.20052
Positive sequence inductance L1, H/KM	0.00092974
Zero sequence inductance L0, H/KM	0.0032829
Zero sequence mutual inductance L0m, H/KM	0.0020802
Positive sequence capacitance C1, F/KM	1.2571e-008
Zero sequence capacitance C0, F/KM	7.8555e-009
Zero sequence mutual capacitance C0m, F/KM	-2.0444e-009
Line Length, KM	100

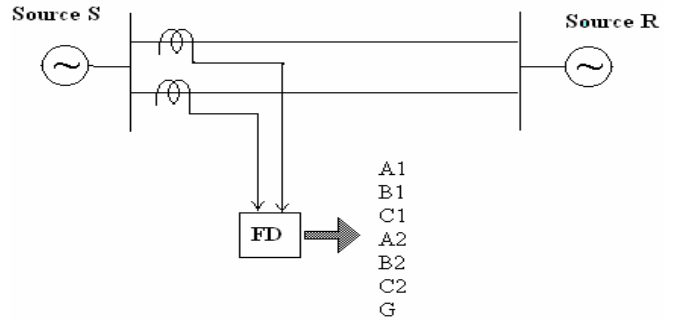

Fig. 1 power System under Study

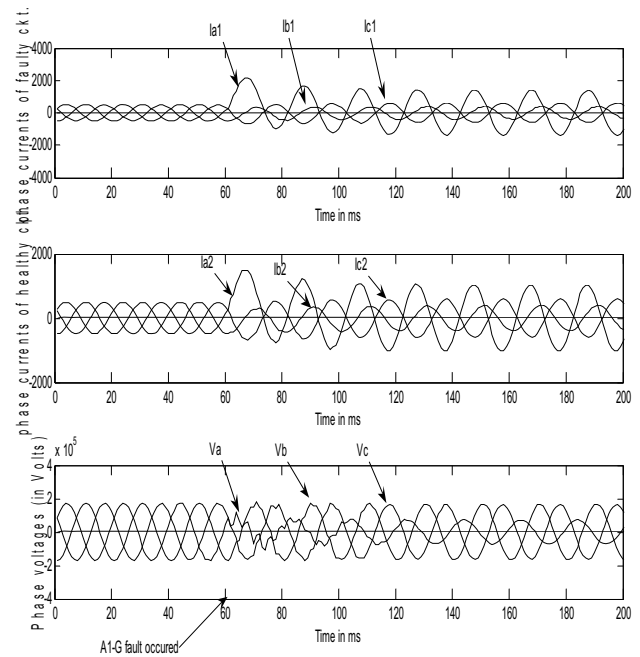

Fig. 2 typical voltage and current waveforms for a single-phase-earth fault in phase-A1 of ckt-1

III. ARTIFICIAL NEURAL NETWORK BASED FAULT DETECTOR AND CLASSIFIER

A. Design Process

The design process of the ANN based fault detector and classifier goes through the following steps:

- Preparation of a suitable training data set comprising of all possible cases that the ANN needs to learn.
- Selection of a suitable ANN structure for a given application.
- Training the ANN.
- Evaluation/validation of the trained ANN using test patterns to check its correctness in generalization.

The training data set of an ANN contains the necessary information to map the input patterns to corresponding output patterns. Combinations of different fault conditions were considered and training patterns were generated by simulating line to ground fault on phases A1 & A2 of double circuit transmission line with varying power system network

conditions i.e. fault location, fault resistance and fault inception angle were changed to obtain training patterns covering a wide range of different power system conditions as shown below in Table II. The simulated training data set were used to train the ANN-based fault detector and classifier.

TABLE II  
TRAINING PATTERNS DATA GENERATION

Sl. No.	Parameter	Set value
1.	Fault type	A1G & A2G
2.	Fault location Lf (km)	0, 10, 20, 30, ...80 and 90 km
3.	Fault inception angle	0 & 90 deg
4.	Fault resistance	0, 50 and 100 Ω

**B. Input and output selection**

Phase currents at the relay location change significantly when a fault occurs on a transmission line. The principle of variation of current signals before and after the fault incidence is used and a fast and reliable ANN based fault detector and classifier module is designed to detect the fault and classify the fault type.

Current signals are sampled at a rate of 1KHz. Samples of each of the phase currents taken at any instant are compared with the samples of the same phase current taken half cycle before and one cycle before. These superimposed signals are made based on the combination of the current samples using equations 1-3 for each circuit. In these equations SupA1, SupB1 and SupC1 correspond to phases A1, B1 and C1 phase of circuit-1 and similarly superimposed signals for circuit-2 can be generated using the same equation. The resultant six superimposed signals are considered as the first six inputs to the ANN based fault detector and classifier.

$$\text{SupA1} = i_{A1}(n) + 2i_{A1}(n-N/2) + i_{A1}(n-N) \quad (1)$$

$$\text{SupB1} = i_{B1}(n) + 2i_{B1}(n-N/2) + i_{B1}(n-N) \quad (2)$$

$$\text{SupC1} = i_{C1}(n) + 2i_{C1}(n-N/2) + i_{C1}(n-N) \quad (3)$$

In equations 1-3, n is the sample number and N is the number of samples per cycle. Zero and negative sequence components of each circuit currents are considered as another input to the ANN based fault classifier. Thus the network has 10 normalized inputs (three superimposed currents, zero & negative sequence currents of each circuit). Seven outputs were considered to determine whether each of the coupled line phases A1, B1, C1, A2, B2, C2 and/or neutral N are present in the fault loop. Based on the fault type which occurs on the system, output should be 0 or 1.

**C. Patterns Generation and Preprocessing**

The simulated power system data obtained through MATLAB® software simulation are used as the input information to train the proposed neural network. Network training pattern generation process is depicted in Fig. 3. Preprocessing is useful method that significantly reduces the size of the neural network and improves the performance and speed of training process [10]. Three phase current input signals of each circuit were processed by simple 2nd-order low-pass Butter worth filter. The filter had a cut-off frequency

of 400 Hz, which introduces just a small time delay. Phase current signals of each circuit are sampled consecutively and the superimposed inputs of the network are prepared using equations 1-3. Zero and negative signal inputs are estimated using sequence analyzer block of MATLAB® SimPowerSystem toolbox. It should be mentioned that the input signals have to be normalized in order to reach the ANN input level (±1). The routine ‘premnx’ of the neural network toolbox of MATLAB® software is used to normalize the input signals.

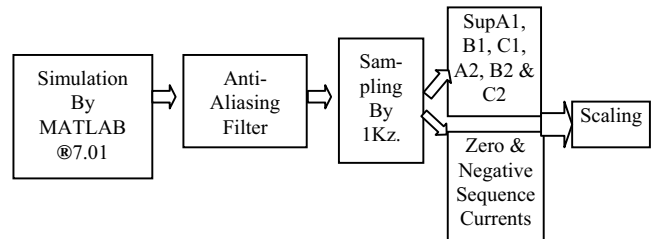

Fig. 3 training patterns generation process

**D. Structure of ANN Based Fault Classifier**

A major issue in the design of ANN architecture is to ensure that when choosing the number of hidden layers/hidden neurons, its attribute for generalization is well maintained. In this respect, since there is no parametric/theoretic guidance available, the design has to be based on a heuristic approach [11]. However, it is now widely accepted that ANN with one hidden layer is capable of solving most nonlinear problems involving pattern classification. With regard to the question of the number of hidden neurons, the only proposed method of determining the optimum number is by comparative cross validation amongst several ANNs, and this has been the methodology adopted herein [12].

The selected network structure is shown in Fig. 4. One hidden layer was found to be adequate for the fault classification application. Hyperbolic tangent function was used as the activation function of the hidden layer neurons. Pure linear function was used for the output layer [2].

Various networks with different number of neurons in their hidden layer were trained with Back Propagation algorithm and Levenberg-Marquardt (LM) algorithm. The LM algorithm is a nonlinear least square algorithm applied to learning of the multilayer neurons. It was found that the networks trained with the LM algorithm provide better results compared with the results of the networks trained with the BP algorithm. Therefore, it was decided to use the LM training algorithm for this application.

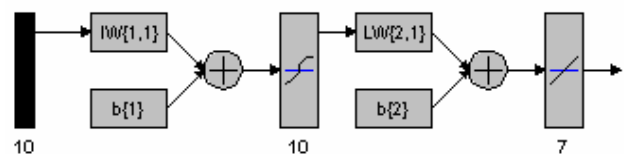

Fig. 4 structure of ANN based fault detector and classifier

### E. Training with Levenberg-Marquardt algorithm

Fig.5 shows the corresponding RMS error of the ANN based Fault Detector and Classifier with the preprocessed training sets. As can be seen, the ANN output error rapidly converges to the desired level. It has been found that a single hidden layer network with 10 neurons in hidden layer and 7 neurons in output layer (10-10-7) is capable of minimizing the mean square error (mse) to a final value of 0.000000522565. This learning strategy converges quickly. One can see that during learning the mse decreases in 100 cycles to 0.000000522565 (instead of first cycle mse 2.78).

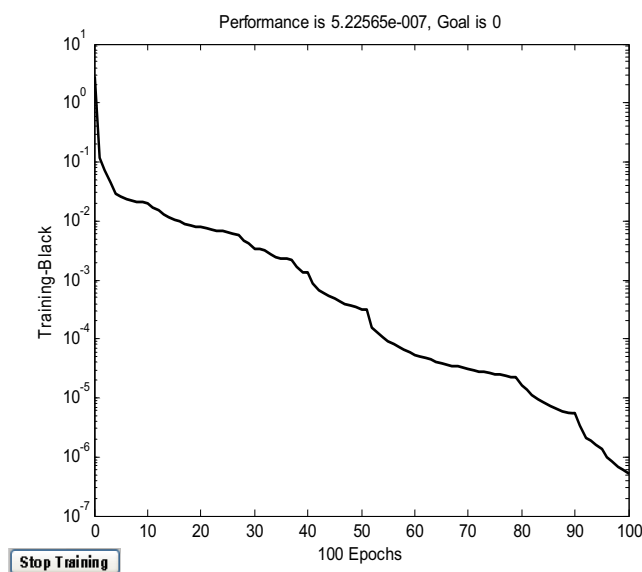

Fig. 5 training figure obtained with Levenberg-Marquardt algorithm for ANN based fault detector and classifier

## IV. TEST RESULTS OF ANN BASED FAULT DETECTOR AND CLASSIFIER

After training, the neural network based fault Detector and Classifier was extensively tested using independent data sets consisting of fault scenarios never used previously in training. Fault type, fault location and fault inception time, power angle  $\delta_s$  were changed for different faults of the validation/test data set to investigate the effects of these factors on the performance of the proposed FL. Extreme cases like faults near the protection zone boundary including fault resistance were also included in the validation data set. The network was tested by presenting 240 different single line to ground faults with varying fault locations ( $L_f$ ), fault inception angles ( $\phi_i$ ) and fault resistance ( $R_f$ ). All 240 faults are correctly classified in less than one cycle time.

For example, test result for a single phase to ground fault in phase A1 occurs at time 60 ms (0 deg. fault inception angle) is shown in fig. 6. The fault location was 90 km from the relay location with fault resistance of 100 $\Omega$ , while the relative angle of the sending-end source with respect to the angle of the receiving-end source was 45 degrees. The ANN based Fault detector and Classifier is able to detect and

classify the fault rapidly and accurately. Thus, even the extreme fault case of high impedance fault near the far end of the line is detected and classified rapidly by the developed ANN based Fault detector and Classifier.

## V. ANALYSIS OF THE INFLUENCE OF VARIOUS FACTORS

### A. Influence of fault resistance

In practice, a fault resistance has a significant effect on the measured currents at the two ends of the line. Therefore, the accuracy achievable with regard to the zone 1 reach setting is very much dependent on the value of the fault resistance. Conventional protection schemes, such as distance, cannot make a correct decision for the full 80% of the line at high fault resistances, i.e. there is a tendency to either significantly overreach or underreach. However, the adaptive protection scheme employing ANN solves this problem in a very satisfactory manner. In this respect, although the training sets contain only fault data with two values of fault resistances at only a few fault positions, the ANN can nevertheless correctly test fault data from fault resistance  $R_f = 0 \Omega$  up to  $R_f = 100 \Omega$ , and the results are shown in Table III. This effectively means that the trained ANN is robust to fault resistance variations due to the fact that an ANN is a nonlinear compensator which adapts to the variation between faulted voltages, currents and fault positions under different fault resistance conditions.

### B. Influence of fault inception angle

The ANN has been trained with training sets under 0 and 90° fault inception angles only, i.e. when the 'A'-phase voltage passes through 0°/90°. However, the ANN can correctly test fault data with inception angle between 0° and 90° fault inception angles also, as shown in Table III. Thus the trained ANN is robust to fault inception angle variations.

The proposed ANN based Fault detector and Classifier results for a few faults with different system conditions are presented in Table III.

## VI. CONCLUSIONS

This work proposes a novel adaptive protection scheme based on ANN, which addresses the problems experienced by conventional distance protection for double circuit lines with remote end infeed arising principally due to mutual coupling under different fault conditions. The adaptive protection scheme is tested under a defined fault type, but different fault locations, fault resistances and fault inception angles and the tripping time is within a quarter cycle in all the cases. All the test results clearly show that the proposed adaptive protection technique is well suited for double-circuit lines with remote end infeed. It should be mentioned that the performance of the protection technique has been illustrated with reference to only a single-phase-earth fault as this is the most frequently occurring fault (over 90% of all faults) in transmission networks.

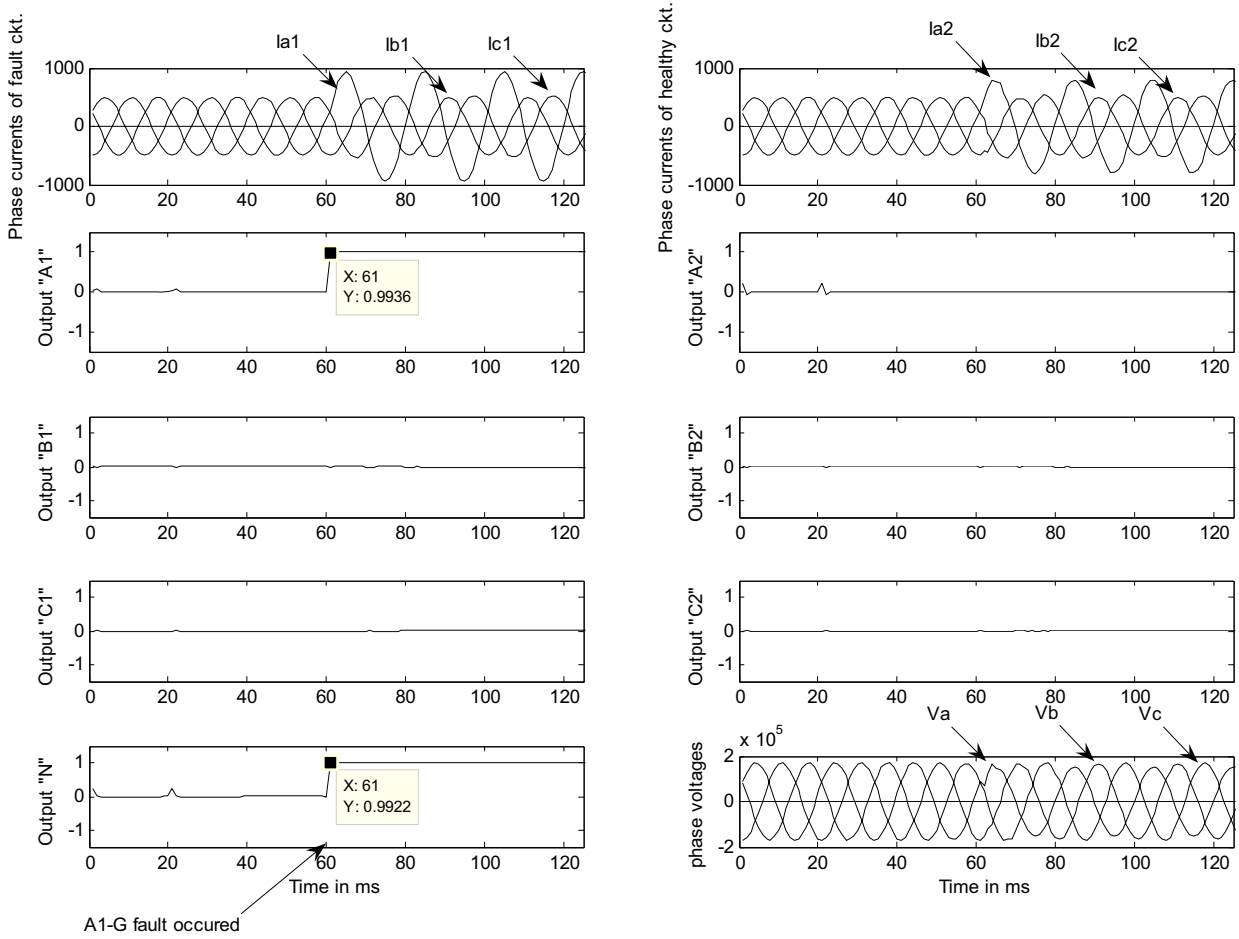

Fig. 6 test result of phase to ground on phase “A1” of ckt-1 at 0 degrees inception angle (inception time 60ms) at 90 KM at 100 Ω fault resistance

TABLE III  
ANN BASED FAULT DETECTOR AND CLASSIFIER TEST RESULTS

Fault type	Fault Location Lf (km)	Fault Inception angle $\Phi_i$ (°)	Fault Resistance Rf (Ω)	ANN based Fault detector and Classifier Output						
				A1	B1	C1	A2	B2	C2	N
A1G	25	45	0	1.0011	0	0	0	0	0	1.0013
A1G	45	90	90	1.0003	0	0	0	0	0	1.0003
A1G	55	0	40	1.0004	0	0	0	0	0	1.0005
A1G	67	45	80	0.9994	0	0	0	0	0	1.0004
A1G	88	0	20	1.0001	0	0	0	0	0	1.0001
A1G	90	0	100	0.9936	0	0	0	0	0	0.99219
A2G	77	90	90	0	0	0	0.99881	0	0	1.034
A2G	68	45	70	0	0	0	0.99836	0	0	0.99875
A2G	57	45	60	0	0	0	1	0	0	1.0004
A2G	84	90	40	0	0	0	0.99703	0	0	1.0006
A2G	13	0	10	0	0	0	1	0	0	1.0001
A2G	90	45	100	0	0	0	1.0092	0	0	1.0073

REFERENCES

- [1] M. Kezunovic, "A Survey of Neural Net Application to Protective Relaying and Fault Analysis," *Eng. Int. Sys.*, vol.5, no. 4, pp. 185-192, Dec. 1997.
- [2] Anamika Jain, V.S. Kale and A.S. Thoke, "Application of artificial neural networks to transmission line faulty phase selection and fault distance location," *Proceedings of the IASTED International conference "Energy and Power System"*, Chiang Mai, Thailand, Mar. 29-31, 2006, pp. 262-267.
- [3] R. K. Aggarwal, Q.Y. Xuan, A.T. Johns, and R.W. Dunn, "Fault classification for double-circuits using self-organization mapping neural network," *Proc. 32nd Universities Power Engineering Conf.*, 1 September 1997.
- [4] A. J. Mazon et al., "A new approach to fault location in two-terminal transmission lines using artificial neural networks," *Electric Power Systems Research*, vol. 56, no. 3, pp. 261-266, December 2000.
- [5] D. V. Coury and D.C. Jorge, "Artificial Neural Network Approach to Distance Protection of Transmission Lines," *IEEE Trans. on Power Delivery*, vol. 13, no. 1, pp. 102-108, 1998.
- [6] S.A. Khaparde, N. Warke and S.H. Agarwal, "An adaptive approach in distance protection using an artificial neural network," *Electric Power Systems Research*, vol. 37, no. 1, pp. 39-46, April 1996.
- [7] Fan Chunju, K.K. Li, W.L. Chan, Yu Weiyong and Zhang Zhaoning, "Application of wavelet fuzzy neural network in locating single line to ground fault (SLG) in distribution lines," *International Journal of Electrical Power & Energy Systems*, vol. 29, no. 6, pp. 497-50, July 2007.
- [8] Bhavesh Bhalja, R. Maheshwari, "trends in adaptive distance protection of multiterminal and double-circuit lines," *Electric Power Components and Systems*, vol. 34, no. 6, pp. 603-617, June 2006.
- [9] R. N. Mahanty, P.B.D Gupta, "Application of RBF neural network to fault classification and location in transmission lines," *IEE Proceedings Generation, Transmission and Distribution*, vol. 151, pp. 201- 212, 2004.
- [10] T. Dalstain, and B. Kulicke, "Neural Network-Approach to Fault Classification for High Speed Protective Relaying," *IEEE Trans. on Power Delivery*, vol. 10, no. 2, pp. 1002-1011, Apr. 1995.
- [11] S. Haykin, *Neural Networks*, IEEE Press, New York, 1994.
- [12] H. Demuth & M Beale, *Neural Network toolbox – for Use with Matlab®*.



Dr. R.N. Patel did his B.E. in Electrical Engineering in year 1997. He acquired his M. Tech. and Ph. D. (Power Systems) degrees from IIT Delhi in years 1998 and 2002 respectively. He has worked as a faculty of Electrical Engineering in IIT Roorkee during year 2003-2006. Presently he is working with the Electrical Engineering department at SSCET, Bhilai, India. His main fields of interest are: Power System dynamics and Stability, Modelling of Power Systems and AI applications to Power Systems. Dr. Patel has more than 45 publications in various International Journals and Conferences.



Anamika Jain received her Bachelor Degree in Electrical Engineering from RGPV Bhopal in 2002 and M.Tech in Integrated Power Systems from V.N.I.T., Nagpur, India in 2006. She is working as Assistant Engineer in the Chhattisgarh State Electricity Board, Raipur, C.G, India. Her research interest is in application of ANN to Power System protection.



Dr. A.S. Thoke did his B.E., M. Tech. & PhD. all in Electrical Engineering. He is a Professor in Electrical Engineering Department at National Institute of Technology, Raipur (C.G.), India. Dr. Thoke has a teaching & research experience of 32 years. His fields of interest are application of Artificial Intelligence to Power system with particular interest in protection. Dr. Thoke is Member of IEEE (03).