

# Heat Transfer at Convective Solid Melting in Fixed Bed

Stelian Petrescu, Adina Frunză, and Camelia Petrescu

**Abstract**—A method to determine experimentally the melting rate,  $r_m$ , and the heat transfer coefficients,  $\alpha_v$  (W/(m<sup>2</sup>K)), at convective melting in a fixed bed of particles under adiabatic regime is established in this paper. The method lies in the determining of the melting rate by measuring the fixed bed height in time. Experimental values of  $r_m$ ,  $\alpha$  and  $\alpha_v$  were determined using cylindrical particles of ice ( $d = 6.8$  mm,  $h = 5.5$  mm) and, as a melting agent, aqueous NaCl solution with a temperature of 283 K at different values of the liquid flow rate ( $11.63 \cdot 10^{-6}$ ,  $28.83 \cdot 10^{-6}$ ,  $38.83 \cdot 10^{-6}$  m<sup>3</sup>/s).

Our experimental results were compared with those existing in literature being noticed a good agreement for Re values higher than 50.

**Keywords**—Convective melting, fixed bed, packed bed, heat transfer, ice melting.

## I. INTRODUCTION

HEAT transfer in liquid-solid systems with and without phase change is frequently meet in chemical, food, siderurgic and other industries. From this reason, the literature contains a great number of papers related to this subject. Some of them [1÷12] approach the study of heat and mass transfer in fixed bed of particles without phase change. A few works [13, 14] refer to the heat transfer accompanied by melting in grain-fixed bed. In these papers [1÷14] are presented the results of experimental and theoretical investigations on heat transfer in fixed bed of spherical, cylindrical, pellet and other kind of particles. Newtonian and non-newtonian power law liquids are used as a melting agent.

Thus, Pfeffer and Happel [5] in their theoretical study assume the fixed bad as an ensemble of isolated spherical particles, the distance among them being a function of the porosity. Le Clair [6] compares the cell model and the experimental results of heat and mass transfer in fixed and fluidized bed with a Newtonian liquid as melting agent.

Kawase and Ulbrecht [8] developed a model for heat and mass transfer from a non-newtonian power-law fluid to particles in fixed-grain bed. The model was obtained on the basis of Blake-Kozeny equation for porous medium and the

solution of Lévêque available for laminar flow. Shukla et al. [12] studied numerically the heat transfer in forced convection at the flow of a non-newtonian power-law fluid in fixed and fluidized bed of spherical particles.

Nishimura et al. [13] proposed a mathematical model used for the simulation of mass transfer accompanied by melting in fixed bed. The results obtained on the basis of this model were compared with experimental data concerning the melting of polyethylene and polypropylene pellets. Masashi et al. [14] investigated experimentally the melting process of an ice particle in fixed bed using water as a melting agent.

In this paper was established a method to determine experimentally the melting rate and heat transfer coefficients related to the volume unit ( $\alpha_v$ ) and area unit ( $\alpha$ ) at the convective melting of a cylindrical particle in fixed bed. The method consists in determining the melting rate by measuring the variation of the fixed bed height in time. Based on this method the values of melting rate and  $\alpha_v$  and  $\alpha$  coefficients were determined experimentally using cylindrical ice particles in aqueous solution of sodium chloride.

## II. METHOD TO DETERMINE MELTING RATE AND $\alpha_v$ AND $\alpha$ HEAT TRANSFER COEFFICIENTS

The melting rate of particles in a fixed bed crossed by a liquid is defined by the relationship:

$$r_m = -\frac{dm_s}{V \cdot dt} \quad (1)$$

Particle (solid) mass in the bed can be expressed as follows:

$$m_s = \rho_s \cdot V(1-\varepsilon) \quad (2)$$

From Eqs. (1) and (2) it results:

$$r_m = -\frac{d[\rho_s \cdot V(1-\varepsilon)]}{V \cdot dt} \quad (3)$$

or

$$r_m = -\frac{\rho_s}{H} \frac{d[H(1-\varepsilon)]}{dt} \quad (4)$$

If the porosity of the fixed bed remains unchanged in time then  $\varepsilon = \varepsilon_0$ , and Eq. (4) becomes:

$$r_m = -\frac{\rho_s(1-\varepsilon)}{H} \frac{dH}{dt} \quad (5)$$

When the particles have the same initial diameter and their number is constant, the melting rate can be expressed as follows:

$$r_m = -\frac{(1-\varepsilon)}{V_p} \cdot \frac{dm_p}{dt} \quad (6)$$

Since  $m_p = \rho_s \cdot V_p$  and  $V_p = \pi \cdot d_e^3 / 6$  Eq. (6) takes the form:

Stelian Petrescu is with "Gh. Asachi" Technical University of Iasi, Faculty of Chemical Engineering and Environmental Protection, Department of Chemical Engineering, 700050, Romania; e-mail: spetresc@ch.tuiasi.ro).

Adina Frunză, is with the "Gh. Asachi" Technical University of Iasi, Faculty of Chemical and Environmental Protection Engineering, Department of Chemical Engineering, 700050, Romania.

Camelia Petrescu, is with the Technical University of Iasi, Faculty of Electrical Engineering, Bd. D. Mangeron, no.53, Iasi, Romania (e-mail: campet@ee.tuiasi.ro).

$$r_m = -\frac{3\rho_s \cdot (1-\varepsilon)}{d_e} \cdot \frac{dd_e}{dt} \quad (7)$$

The melting rate can be related to the area unit. Hence, one could define a melting rate,  $r_m'$ , with the relationship:

$$r_m' = -\frac{dm_s}{A \cdot dt} \quad (8)$$

Considering the particles have initially the same diameter and their number is constant, it can be written:

$$r_m' = -\frac{\rho_s \cdot dV_p}{A_p \cdot dt} \quad (9)$$

Taking into account that  $V_p = \pi \cdot d_e^3 / 6$  and  $A_p = \pi \cdot d_e^2 / \Psi$  Eq. (3) becomes:

$$r_m' = -\frac{\rho_s \cdot \Psi}{2} \cdot \frac{dd_e}{dt} \quad (10)$$

The equivalent diameter of a particle at a given time can be expressed as a function of the initial diameter  $d_e$  with the following relationship:

$$d_e = d_e^0 \cdot \sqrt[3]{\frac{(1-\varepsilon)H}{(1-\varepsilon_0)H_0}} \quad (11)$$

If the fixed bed porosity is constant,  $\varepsilon = \varepsilon_0$ , Eq. (11) simplifies to:

$$d_e = d_e^0 \cdot \sqrt[3]{\frac{H}{H_0}} \quad (12)$$

From Eqs. (7) and (10) it gives:

$$r_m = \frac{6(1-\varepsilon)}{\Psi \cdot d_e} \cdot r_m' = a_v \cdot r_m' \quad (13)$$

In order to determine the volume-related heat transfer coefficient,  $\alpha_v$ , it is used the equation of heat transfer:

$$\Delta H_m \cdot r_m = \alpha_v (T_\infty - T_i)_{mean} \quad (14)$$

The coefficient of heat transfer  $\alpha$  can be obtained with the equation:

$$\Delta H_m \cdot r_m' = \alpha (T_\infty - T_i)_{mean} \quad (15)$$

From equation (13) and (14) it results:

$$\alpha_v = a_v \cdot \alpha \quad (16)$$

### III. EXPERIMENTAL

The experimental installation graphically represented in Fig. 1 consists in a vertical cylindrical column (1) made of thermo-resistive glass of 5 mm. The column has an interior diameter of 0.055m and a height of 0.6m. At the lower part the column is provided with a conical section (2) of stainless steel fixed through flanges with three couplings. Above the cylindrical column a cylindrical section of stainless steel (3) is fixed through flanges. In this section there is a lid made of rubber (4) where is fixed a stainless steel funnel (5), which is provided with a stainless steel sieve (6) to support the fixed bed of ice grains.

The liquid phase (aqueous solution of sodium chloride) is poured into column through a coupling located at the lower part, being transported with the aim of a centrifugal pump (7). The centrifugal pump exhausts the liquid from the reservoir (8). The rotameter (9) and valve (10) were used to measure and regulate the flow rate of liquid phase.

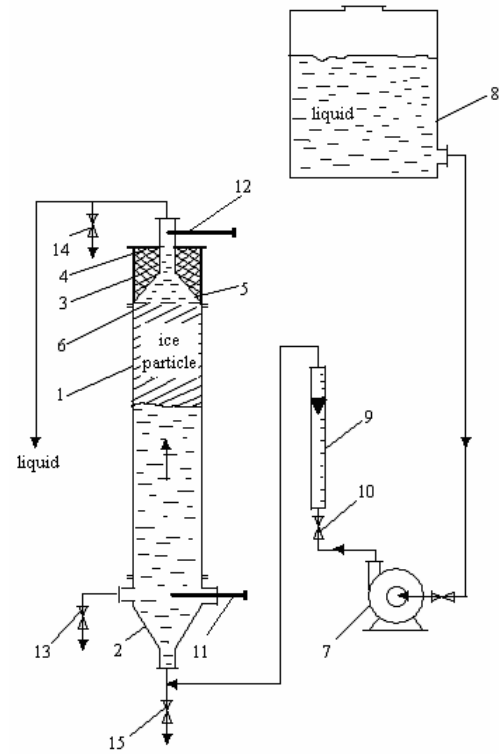

Fig. 1 Experimental installation (1- column, 2 - conical section, 3 – cylindrical section, 4 – lid, 5 – funnel, 6 – sieve, 7 – pump, 8 – reservoir, 9 – rotameter, 10, 13 and 14 – valves, 12 – thermocouples).

Thermo-elements (11) and (12) measuring the liquid temperature at in the entrance and, respectively, exit of the ice-grain fixed bed are fixed in the coupling from the lower part of column and the coupling at the column outlet of the liquid phase. The drawing of liquid phase samples at the entrance and exit of the fixed bed is achieved with the valves (13) and (14).

In investigations were used cylindrical ice grains with a diameter of 6.8mm, height of 5.5 mm and initial temperature of 266K. The grains were introduced into column at the upper part achieving a fixed bed with the height of 0.113 m. Aqueous solution of sodium chloride 10 % mass was used as liquid phase at the temperature of 283K. Three values of the liquid flow rate ( $11.63 \cdot 10^{-6}$ ,  $28.83 \cdot 10^{-6}$ ,  $38.83 \cdot 10^{-6}$  m<sup>3</sup>/s) were employed.

Before immersing the ice particles into the column, the centrifugal pump was turned on to provide the solution to the column. Since the ice has a lower density than the solution of NaCl, the fixed bed of particles forms at the upper part of the column.

In order to obtain a better thermal isolation of the column, the installation was placed into a thermostated chamber, the temperature being maintained at 283-284K. Due to this thermostated chamber and that the high thickness of the glass column, it can be assumed that the melting process takes place without heat change with the external medium, that is, in adiabatic regime.

IV. RESULTS AND DISCUSSION

The height variation of the fixed bed of cylindrical ice particles as a function of time, concentration and temperature of sodium chloride solution at the exit of the fixed bed were determined experimentally using the installation presented in Fig. 1. The results obtained are presented in Table I and Figs. 2 and 3. As it can be noted the solution temperature and the height of the fixed bed of particles decrease in time, and the concentration of sodium chloride in solution at the outlet decreases in time at the beginning, and then increases.

TABLE I  
SOLUTION TEMPERATURE AT THE COLUMN OUTLET

$M_V^{in} = 11.63 \cdot 10^{-6} m^3/s$		$M_V^{in} = 28.83 \cdot 10^{-6} m^3/s$		$M_V^{in} = 33.83 \cdot 10^{-6} m^3/s$	
t (s)	T <sub>∞</sub> (K)	t (s)	T <sub>∞</sub> (K)	t (s)	T <sub>∞</sub> (K)
0	283	0	283	0	283
5	281.6	5	277.5	5	276.1
10	280.3	10	277.1	10	276.1
15	279.0	15	277.2	15	277.0
20	278.1	20	277.7	20	276.8
25	277.4	25	278.5	25	277.5
30	276.9	-	-	-	-

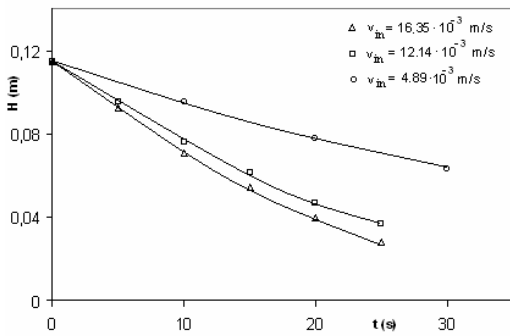

Fig. 2 Variation of the height of ice particle fixed bed in time

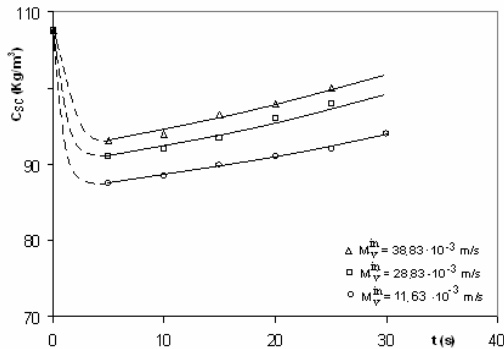

Fig. 3 Variation of NaCl concentration in solution at column outlet as a function of time

In order to determine the melting rate,  $r_m$ , it is necessary to know the values of the fixed bed porosity at the initial time ( $\epsilon_0$ ) and at a given time ( $\epsilon$ ). For this purpose were drawn up the mass balances for solid and liquid phases giving the relationships:

$$N_w = \frac{\rho_s \cdot S}{t} [(1 - \epsilon_0)H_0 - (1 - \epsilon)H] \quad (17)$$

$$N_w = \frac{M_V^{in} \cdot \rho^{in} (x_w^{ex} - x_w^{in})}{1 - x_w^{ex}} \quad (18)$$

From eq. (17) it gives:

$$\epsilon = 1 - \frac{(1 - \epsilon_0)H_0}{H} + \frac{N_w \cdot t}{\rho_s \cdot S \cdot H} \quad (19)$$

The porosity of cylindrical-ice-particle fixed bed was determined at different times ( $t = 5, 10, 15, 20, 25s$ ) using eqs. (18) and (19), and the data from Figs. 2 and 3, and Table 1. The results obtained are listed in Table II. It can be noted that the fixed bed porosity varies lightly in time. Also, the liquid flow rate does not influence significantly the porosity.

TABLE II  
POROSITY OF CYLINDRICAL ICE PARTICLE FIXED BED.

t (s)	$10^6 M_V^{in} (m^3/s)$		
	11.63	28.83	33.83
5	0.3946	0.3985	0.3986
10	0.3966	0.3930	0.3978
15	0.3951	0.3966	0.3944
20	0.3954	0.3905	0.3934
25	0.3903	0.3950	0.3829
30	0.3954	-	-

With the aim of eq. (4) there was calculated the melting rate,  $r_m$ , and the results obtained are shown in Fig. 4. Fig. 5 is represented on the basis of data in Fig. 4 and contains the variation of melting rate,  $r_m$ , as a function of the NaCl solution flow rate at the entrance area in the fixed bed ( $v_{in}$ ).

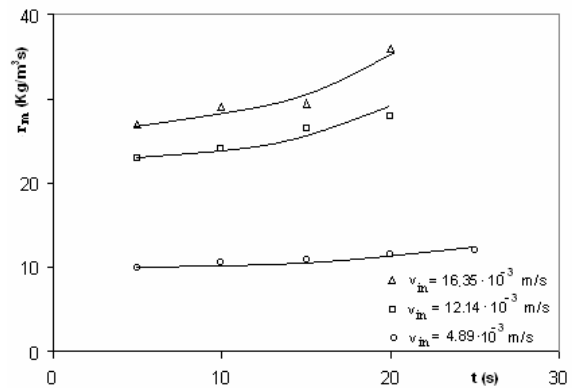

Fig. 4 Melting rate ( $r_m$ ) dependence on time

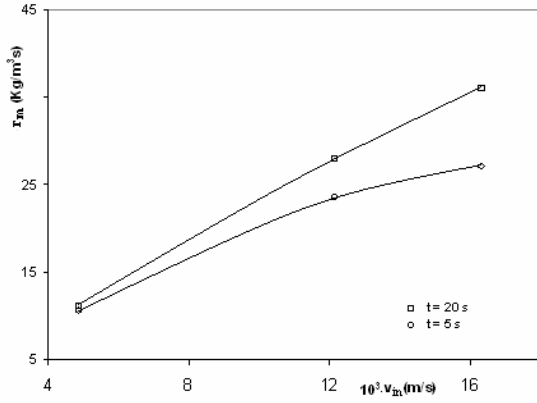

Fig. 5 Influence of NaCl solution flow velocity at fixed bed entrance on the melting rate ( $r_m$ )

It can be seen that the melting rate of the cylindrical-ice particles in fixed bed increases in time. This may be explained by the increase of the particle specific-surface area ( $a_v$ ) in time due to the continuous melting of the particles. As it can be seen in Fig. 6,  $\Psi \cdot a_v$  increases in time with higher melting rates.

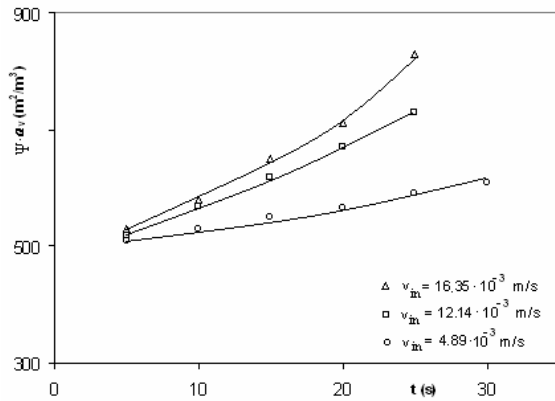

Fig. 6 Dependence  $\Psi \cdot a_v - t$  at convection melting of cylindrical ice particle in NaCl solution

The sodium chloride solution flow rate and, respectively, flow velocity influences positively the melting rate of particles in fixed bed so as it can be seen in Fig. 5. The increasing of feed flow rate of solution leads to an increase of its velocity through the fixed bed and, consequently, increases the liquid-solid heat transfer. An additional enhance of the liquid-solid heat transfer is given by the increasing of the solution flow rate (velocity) within the fixed bed due to the melting process of ice particles. In Fig. 7 are represented the liquid phase flow velocity ( $v_{ex}$ ) at the fixed bed exit and through the fixed bed as a function of time. To calculate the liquid phase flow velocity at the fixed bed exit it was used the relationship:

$$v_{ex} = \frac{N_w + M_V^{in} \cdot \rho^{in}}{\rho^{ex} \cdot S} \quad (20)$$

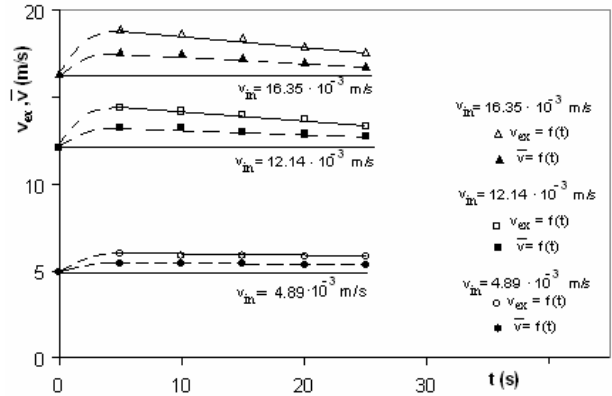

Fig. 7 Variation of NaCl solution flow velocity at the fixed bed exit and average velocity as a function of time

As it can be noted both velocities,  $v_{ex}$  and  $\bar{v}$ , increase at the beginning of the melting process, and then decrease in time as the melted ice quantity becomes lower.

Further the volume related heat transfer coefficient ( $\alpha_v$ ) was determined on the basis of the melting rate values,  $r_m$ , and eq. (14). Temperature values at the interface ( $T_i$ ) were calculated with solid-liquid equilibrium data for the binary system NaCl-H<sub>2</sub>O [16]. Figs. 8 and 9 contain  $\alpha_v - t$ ,  $\alpha_v - v_{in}$  dependences. The dependences in Fig. 8 emphasize the increasing of volume related heat-transfer coefficient in time and as a function of the NaCl solution flow rate (velocity). In Fig. 9 is shown the variation of  $\alpha_v$  transfer coefficient as a function of the solution flow velocity,  $v_{in}$ , at two values of time. The increasing of  $\alpha_v$  coefficient with  $v_{in}$  was expected since the increase of liquid phase feed flow velocity leads to a decreasing of the limiting layer thickness formed around ice particles in the fixed bed.

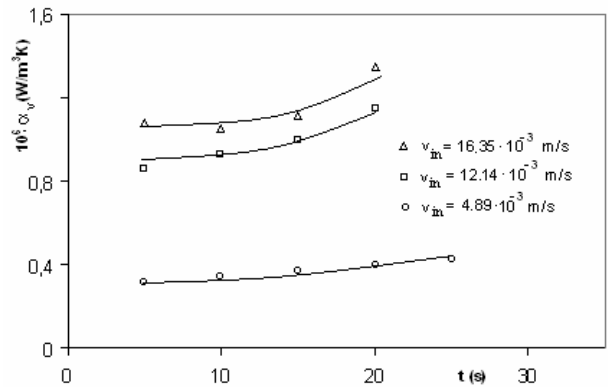

Fig. 8 Variation of heat transfer coefficient related to volume ( $\alpha_v$ ) in time

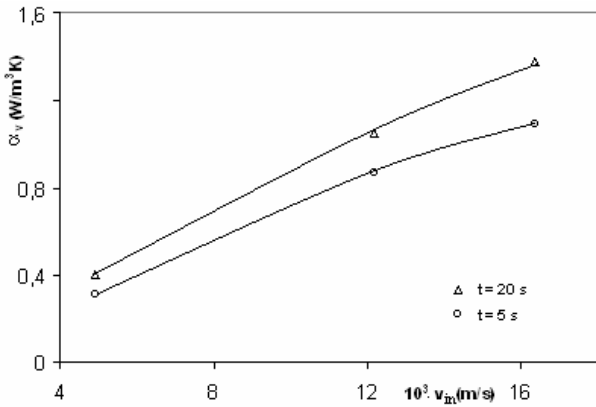

Fig. 9 Influence of liquid phase flow velocity at fixed bed entrance over de heat transfer coefficient related to volume ( $\alpha_v$ )

With the aim of eq. (15) it was determined the  $\alpha$  heat transfer coefficient. For this reason, there were determined the equivalent diameter of ice particles ( $d_e$ ) and the related to area melting rate ( $r_m'$ ) using data in Tables 1 and 2, end relationships (10) and (11). Because the pattern factor of ice particles ( $\Psi$ ) varies in time and hard to estimate, the calculation were performed for lower durations ( $t = 10s$ ) when  $\Psi$  is insignificantly changed. Under these conditions, the pattern factor may be assumed equal to the initial one,  $\Psi_0$ , which is 0.893 for cylindrical ice particles.

In Fig. 10 are graphically represented the values obtained for  $\alpha$  coefficient as a function of liquid phase feed flow velocity. On this plot are represented also the values of  $\alpha = f(v_{in})$  that were calculated using eq. (16) with the data obtained previously for  $\alpha_v$ . It can be noted that there is no significant difference between the values of  $\alpha$  coefficient determined through the two different paths.

In order to verify the experimental results on  $\alpha$  heat-transfer coefficient the criteria equations proposed by Evans and Upadhyay [15] were considered:

$$Nu = 1.48 Re^{0.48} \cdot Pr^{1/3} \tag{21}$$

$$Nu = 1.6218(1 - \varepsilon)^{0.4447} \cdot Re^{0.5553} \cdot Pr^{1/3} \tag{22}$$

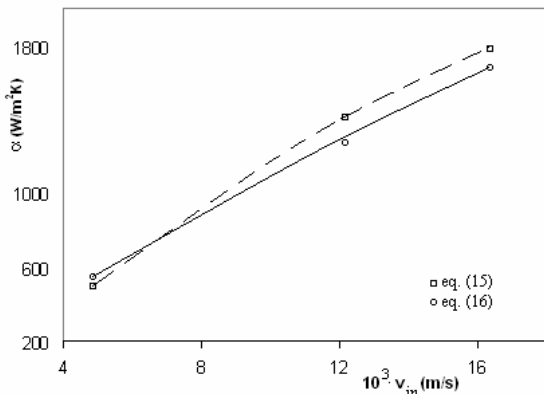

Fig. 10 Influence of NaCl solution flow velocity at fixed bed entrance over de heat transfer coefficient ( $\alpha$ )

In diagram in Fig. 11 are shown the obtained experimental results and those calculated with eqs. (21) and (22)  $\alpha$  heat-transfer coefficient. In order to calculate the Re, Pr and Nu

numbers from eqs. (21) and (22) there were employed average values of the fluid physical properties ( $\rho$ ,  $\eta$ ,  $\lambda$ ,  $C_p$ ) [17]. According to Fig. 11, it results a relatively good agreement between the experimental data and those obtained with eq. (21) for a variation range of Re from 20 to 70. The agreement is better with higher values of the Reynolds number. The experimental values obtained here are 10% lower than those presented by Evans [15] for values of Reynolds number higher than 50.

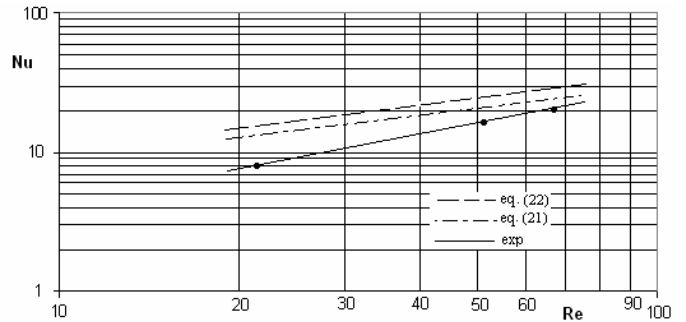

Fig. 11 Dependence of Nusselt number on Reynolds number

#### V. CONCLUSION

In this paper is presented a method to determine experimentally the melting rate and heat transfer coefficient,  $\alpha$  (related to area unit) and  $\alpha_v$  (related to volume unit) at convective melting of cylindrical particle in fixed bed. The method suggested allows one to determine  $\alpha$  and  $\alpha_v$  heat transfer coefficients and melting rate by measuring the variation in time of the height of particle fixed bed.

Using this method there were determined the melting rate and  $\alpha$  and  $\alpha_v$  heat transfer coefficients at the melting of cylindrical ice particles in fixed bed. Sodium chloride aqueous solution was employed as melting agent.

The influence of the liquid phase flow rate over the melting rate and  $\alpha$  and  $\alpha_v$  coefficients was studied.

Experimental results obtained were compared with the results of other authors using two criteria equations from literature. A good agreement between our results and those calculated with the considered criteria equation was obtained for values of Reynolds numbers higher than 50.

#### NOMENCLATURE

- A - area of particle surfaces in fixed bed,  $m^2$ ;
- $A_p$  - area of particle surface,  $m^2$ ;
- $a_v$  - specific interfacial area,  $m^2/m^3$ ;
- $C_p$  - liquid-phase specific heat,  $J/Kg \cdot K$ ;
- $d_e$  - particle equivalent diameter, m;
- H - fixed bed height, m;
- $m_p$  - particle mass, kg ;
- $m_s$  - solid mass in fixed bed, kg;
- $M_v$  - liquid-phase volume flow rate,  $m^3/s$ ;
- $N_w$  - melted solid mass flow rate,  $Kg/s$ ;
- $Nu = \alpha \cdot \Psi_0 \cdot d_e / \lambda$  - Nusselt number;
- $Pr = C_p \cdot \eta / \lambda$  - Prandtl number;

$Re = \rho \cdot \bar{v} \cdot \Psi_o \cdot d_e / \eta$  - Reynolds number;

$r_m$  - melting rate related to volume unit,  $kg/m^3s$ ;

$r_m'$  - melting rate related to area unit,  $kg/m^2s$ ;

$S$  - cross-section area of fixed bed column,  $m^2$ ;

$t$  - time, s;

$T_\infty$  - temperature in bulk liquid - phase, K;

$T_i$  - temperature at solid - liquid interface, K;

$(T_\infty - T_i)_{mean} = \left[ (T_\infty^{in} - T_i^{in}) - (T_\infty^{ex} - T_i^{ex}) \right] / \ln \left[ (T_\infty^{in} - T_i^{in}) / (T_\infty^{ex} - T_i^{ex}) \right]$  -

average driving force of heat transfer;

$v$  - liquid - phase superficial velocity, m/s;

$\bar{v}$  - average liquid - phase superficial velocity, m/s;

$V$  - fixed bed volume,  $m^3$ ;

$V_p$  - particle volume,  $m^3$ ;

$X_w$  - water mass ratio, Water Kg/ solution Kg;

*Greek letters*

$\alpha$  - heat transfer coefficient,  $W/m^2 \cdot K$ ;

$\alpha_v$  - heat transfer coefficient related to volume,  $W/m^3 \cdot K$

$\rho$  - liquid - phase density,  $Kg/m^3$ ;

$\rho_s$  - solid density,  $kg/m^3$ ;

$\Delta H_m$  - melting enthalpy, J/kg;

$\varepsilon$  - fixed bed porosity, non-dimensional;

$\eta$  - liquid - phase dynamic viscous,  $N \cdot s/m^2$ ;

$\lambda$  - liquid thermal - conductivity coefficient,  $W/m \cdot K$ ;

$\psi$  - particle pattern factor, non-dimensional;

*Index*

in - inlet;

ex - outlet;

0 - initial ( $t=0$ ).

[12] R., Shukla, S.D., Dhole, R.P., Chhabra, V., Eswaran, Convective Heat Transfer for Power Law Fluid in Packed and Fluidised Beds of Spheres, *Chem. Eng. Sci.*, 59, 2004, 645-659.

[13] M., Nishimura, Y., Hirabayashi, S., Sugiyama, Heat Transfer Accompanied by Melting in a Fixed Bed of Granular Solids, *Int. Chem. Eng.*, 16, 1976, 169-176.

[14] O., Masashi, H., Koaru, O., Isamu, Melting Process of Packed Beds of Particles by Water Flow, *Proc. ASME-JSME Term.Eng.Conf.*, 3 rd 3, 1991, 327-333.

[15] J., Comiti, M., Renaud, Liquid Solid Mass of Parallelepipedal particles. Energetic Correlation, *Chem. Eng. Sci.*, 1991, 143-152.

[16] Landolt-Börnstein.(1960).*Zahlenwerte und funktionen*, 2teil, Springer Verlag, Berlin.

**Stelian Petrescu**, Dorohoi, 1951, received the MSC degree in Chemical Engineering from the Technical University of Iasi, Romania in 1975, and the Ph.D degree in Chemical Engineering, in 1987 from the same University.

He is a Professor at the Technical University of Iasi, Faculty of Chemical Engineering. His areas of interest are: heat and mass transfer, chemical reaction engineering, solid-liquid phase equilibria, optimal design of chemical engineering equipments.

**Adina Frunza**, Iasi, 1976, received the MSC degree in Chemical Engineering from the Technical University of Iasi, Romania in 2000.

She is currently preparing her Ph.D thesis in Chemical Engineering at the Faculty of Chemical Engineering in the Technical University of Iasi.

**Camelia Petrescu** (M'06), Iasi, 1958, received the MSc degree in Electrical Engineering from the Technical University of Iasi, Romania in 1982 and the Ph.D degree in Electrical Engineering in 1994 from Politehnica University Bucharest, Romania.

She is a Professor at the Technical University of Iasi, Faculty of Electrical Engineering. Her areas of interest include finite element analysis, high frequency dielectric heating, optimal design using evolutionary algorithms and electric power quality.

## REFERENCES

- [1] B.R., Bird, W.E., Stewart, E.N., Lightfoot, *Transport Phenomena*, J.Wiley, New York, 2002.
- [2] J.M., Coulson, J.F., Richardson, *Chemical Engineering*, vol.2, Banckhurst-Heinemann Linacre House, Oxford, 1997.
- [3] F.P., Incropera, D.P., De Witt, *Fundamentals of Heat and Mass Transfer*, J.Wiley, New York, 1996.
- [4] R.H., Perry, D., Green, *Perry's Chemical Engineers' Handbook*, McGraw Hill, New York, 1985.
- [5] R., Pfeffer, J., Happel, An Analytical Study of Heat and Mass Transfer in Multiparticle System at Low Reynolds Numbers, *AIChE Journal*, 10, 1964, 605-611.
- [6] B.P., Le Clair, A.E., Hamilec, Viscous Flow through Particle Assemblages at Intermediate Reynolds Numbers: Heat and Mass Transport, *Institution of Chemical Engineering Series*, 30, 1968, 197-206.
- [7] J.P., Sören, W.E., Stewart, Computation of Fixed Convection in Slow Flow through Ducts and Packed Beds-III Heat and Mass Transfer in a Simple Cubic Array of Spheres, *Chem. Eng. Sci.*, 29, 1974, 827-835.
- [8] Y., Kawase, J.J., Ulbrecht, A New Approach for Heat and Mass Transfer in Granular Beds on the Capillary Model, *Ind. Eng. Chem. Fundam.*, 24, 115-116, 1985.
- [9] J.G.H., Borkink, C.G., Van de Watering, K.R., Westertep, Statistical Character of Bed-Scale Effective Heat Transport Coefficients for Packed Beds, *Chem. Eng. Res. Des.*, 70, 1992, 610-619.
- [10] Y., Kawase, Particle-Fluid Heat / Mass Transfer, Newtonian and Non-Newtonian Fluid, *Warme-und Stoffübertragung*, 27, 1992, 73-76.
- [11] B.K. Rao, Heat Transfer to Power Law fluid Flows through Porous Media, *Journal of Porous Media*, 4, 2001, 339-347.