

# Distribution Voltage Regulation Under Three-Phase Fault by Using D-STATCOM

Chaiyut Sumpavakup, and Thanatchai Kulworawanichpong

**Abstract**—This paper presents the voltage regulation scheme of D-STATCOM under three-phase faults. It consists of the voltage detection and voltage regulation schemes in the  $0dq$  reference. The proposed control strategy uses the proportional controller in which the proportional gain,  $k_p$ , is appropriately adjusted by using genetic algorithms. To verify its use, a simplified 4-bus test system is situated by assuming a three-phase fault at bus 4. As a result, the D-STATCOM can resume the load voltage to the desired level within 1.8 ms. This confirms that the proposed voltage regulation scheme performs well under three-phase fault events.

**Keywords**—D-STATCOM, proportional controller, genetic algorithms.

## I. INTRODUCTION

ELECTRIC power distribution network becomes more increasingly important and plays an essential role in power system planning. This type of power systems has a major function to serve distributed customer loads along a feeder line, therefore under competitive environment of electricity market eservice of electric energy transfer must not be interrupted and at the same time there must provide reliable, stable and high quality of electric power. To complete this challenge, it requires careful design for power network planning. There exist many different ways to do so. However, one might consider an additional device to be installed somewhere in the network. Such devices are one of capacitor bank, shunt reactor, series reactors, automatic voltage regulators and/or recently developed dynamic voltage restorers, distribution STATCOM (our focus), or combination of them [1-2].

Problems of reactive compensation and power quality in power distribution network are to establish an efficient algorithm to command a power conditioning device. During the voltage sag, the load voltage at the bus in which the D-STATCOM is connected can be regulated by injecting compensating current into the system. The injected current is generated through power electronic circuits with a complicated control scheme. From literature there exist several control

strategies which are usually based on mathematical approach [1-2]. In this paper, the proposed method to regulate load voltage under symmetrical short-circuit fault is described.

## II. STRUCTURE AND MODELING OF D-STATCOM

D-STATCOM is one of shunt type power conditioners consisting of i) DC link capacitor, ii) separately phase-controlled switched-mode inverter, iii) isolating transformer, and iv) gate triggering circuit [3] as shown in Fig. 1.

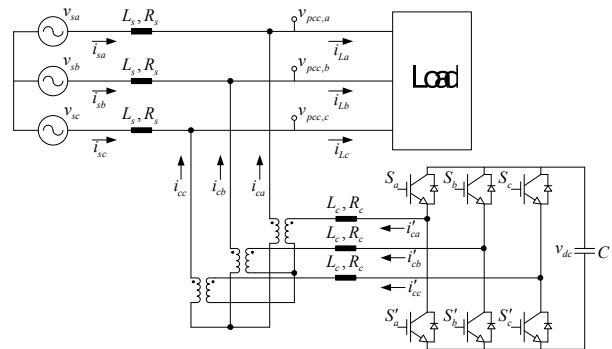

Fig. 1 Circuit structure of D-STATCOM

In steady-state operation with heavy loading or some short-circuit events, D-STATCOM typically injects appropriate compensating current to the point of coupling connection, thus voltage at the load bus regulated by the D-STATCOM will be lifted close to the nominal or a given value. This implies that voltage-controlled source in parallel with impedance is sufficient to represent the D-STATCOM as shown in Fig. 2. In the figure, the D-STATCOM is assumed to be installed at bus 2  $v_c$  and  $R_c + jX_c$  represent phasor voltage and impedance of the D-STATCOM.

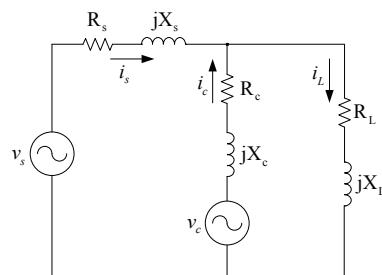

Fig. 2 Equivalent circuit of the D-STATCOM

Manuscript received March 31, 2008. This work was supported in part by the National Research Council of Thailand (Research Grant: SUT7-711-51-12-43) and Suranaree University of Technology, Thailand.

C. Sumpavakup and T. Kulworawanichpong are with the School of Electrical Engineering, Suranaree University of Technology, Nakhon Ratchasima Thailand (phone: +6644-224400; fax: +6644-224601; e-mail: thanatchai@gmail.com).

### III. VOLTAGE DETECTION SCHEME

There are various voltage detection methods. This paper employs the  $0dq$  transformation or alternatively called Park transform [4] as described in following explanation.

Let  $V_{abc}$  and  $V_{0dq}$  be voltage vectors referred to the  $abc$  and  $0dq$  reference frames, respectively. Any voltage vector in the  $abc$  reference can be transformed to the  $0dq$  reference, and vice versa, by using (1).

$$V_{0dq} = R(\theta)P(0)V_{abc} \quad (1)$$

Where  $\theta = \omega t = 2\pi ft$

$$V_{abc} = \begin{bmatrix} V_a \\ V_b \\ V_c \end{bmatrix}; \quad V_{0dq} = \begin{bmatrix} V_0 \\ V_d \\ V_q \end{bmatrix}$$

$$R(\theta) = \begin{bmatrix} 1 & 0 & 0 \\ 0 & \cos\theta & -\sin\theta \\ 0 & \sin\theta & \cos\theta \end{bmatrix}$$

$$P(0) = \sqrt{\frac{2}{3}} \begin{bmatrix} \frac{1}{\sqrt{2}} & \frac{1}{\sqrt{2}} & \frac{1}{\sqrt{2}} \\ 1 & -\frac{1}{2} & -\frac{1}{2} \\ 0 & \frac{\sqrt{3}}{2} & \frac{\sqrt{3}}{2} \end{bmatrix}$$

(1) can be rewritten in more detail as follows.

$$\begin{bmatrix} V_0 \\ V_d \\ V_q \end{bmatrix} = \sqrt{\frac{2}{3}} \begin{bmatrix} 1/\sqrt{2} & 1/\sqrt{2} & 1/\sqrt{2} \\ \cos\theta & \cos(\theta-2\pi/3) & \cos(\theta+2\pi/3) \\ \sin\theta & \sin(\theta-2\pi/3) & \sin(\theta+2\pi/3) \end{bmatrix} \begin{bmatrix} V_a \\ V_b \\ V_c \end{bmatrix} \quad (2)$$

As long as the voltage vector in the  $abc$  reference is balanced, its associated  $0dq$  components are dc signals. To detect any abnormal voltage condition, each of the  $0dq$  components must be checked for its variation.

### IV. VOLTAGE REGULATION SCHEME

To regulate the load voltage at the desired voltage level, a voltage regulation scheme is proposed. Although abnormal voltages can be caused by several events, e.g. supply interruption, sudden load change, arc furnace operation, short-circuit fault, etc, in this paper the voltage regulation under three-phase fault is only our particular study. To regulate the voltage level, its  $0dq$  voltage components at a given load bus must be analyzed and compared with the  $0dq$  desired voltage components. Difference of these two vectors must be reduced by injected the compensating current from D-STATCOM at the point of coupling connection. This control scheme can be done in the  $0dq$  reference as shown in the block diagram of Fig. 3.

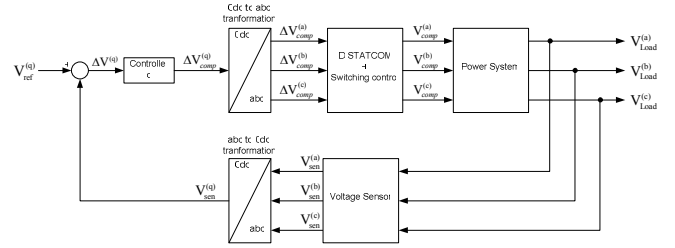

Fig. 3 Complete block diagram of voltage regulation scheme

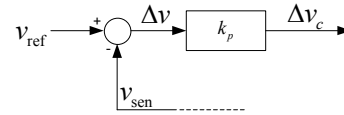

Fig. 4 Structure of Proportional Control

To demonstrate the proposed voltage regulation scheme, the proportional control (P-controller) [5] is introduced. As obviously found in other controller design problems, the proportional gain ( $k_p$ ) is the key to accomplish this regulation. From Fig. 4, the Proportional controller output is assigned by (3). To find an appropriate value of  $k_p$ , some efficient search algorithm, such as genetic algorithms, is employed.

$$\Delta v_c = k_p \Delta v \quad (3)$$

Where  $\Delta v_c$  is the proportional controller output  
 $k_p$  is the proportional gain  
 $\Delta v$  is the voltage error

#### A. Genetic Algorithms: GAs

There exist many different approaches to tune controller parameters. The GAs is well-known [6] there exist a hundred of works employing the GAs technique to design the controller in various forms. The GAs is a stochastic search technique that leads a set of population in solution space evolved using the principles of genetic evolution and natural selection, called genetic operators e.g. crossover, mutation, etc. With successive updating new generation, a set of updated solutions gradually converges to the real solution. Because the GAs is very popular and widely used in most research areas [6-8] where an intelligent search technique is applied, it can be summarized briefly as shown in the flowchart of Fig. 5.

In this paper, the GAs is selected to build up an algorithm to tune  $k_p$  parameters. The procedure to perform the proposed parameter tuning is described as follows. First, time-domain results of the load voltage obtained by simulating the D-STATCOM system in MATLAB™ [9] are collected. Second, the Genetic Algorithms (GADS TOOLBOX in MATLAB™) [10] is employed to generate a set of initial random parameters. With the searching process, the parameters are adjusted to give response best fitting close to the desired response in the  $0dq$  reference signals. To perform the searching properly, its objective function is the key. In this paper, the objective function is defined in (4).

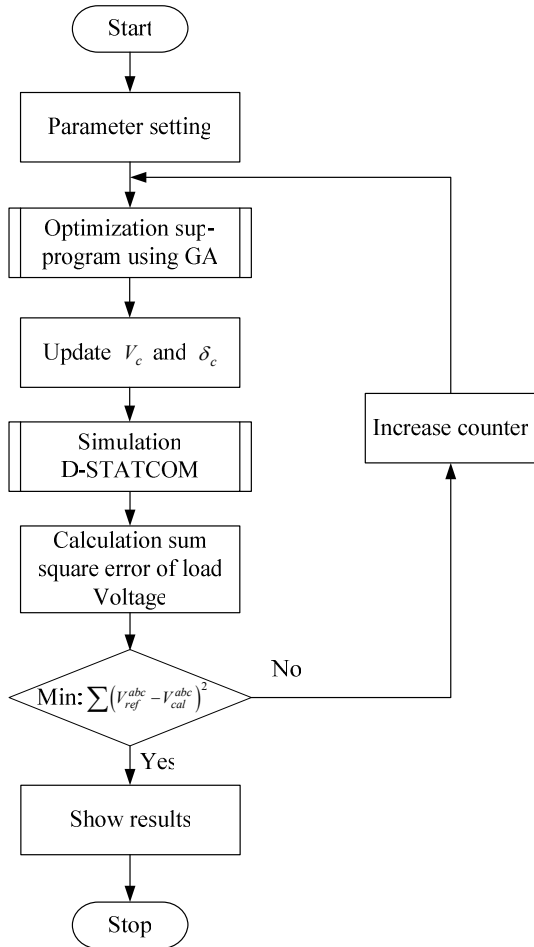

Fig. 5 Flow chart of the genetic algorithm

$$\text{Minimize } f_{obj} = \sum (V_{ref}^{abc} - V_{cal}^{abc})^2 \quad (4)$$

The following are some parameter setting for GADS command to obtain an optimal  $k_p$  parameter.

- Generations: 500
- PopulationSize: 100
- StallGenLimit: 50
- PopInitRange:  $k_p^{0dq} \in [10,13]$

With more than 30 trials, the best proportional parameter for each component in the  $0dq$  reference is given as follows.

$$k_p^{0dq} = 11.7643$$

### V. SIMULATION RESULTS

This section illustrates numerical results of a simplified 4-bus power system equipped with D-STATCOM at bus 3. Characteristics of the system resulting from the operation of the D-STATCOM are simulated by using the MATLAB simulation codes. The specification of the test system is given as follows.

- Input Voltage: 22 kV, 50 Hz
- Line Impedance1: 0.18  $\Omega$ , 0.4 mH
- Line Impedance2: 0.83  $\Omega$ , 1.2 mH
- Line Impedance3: 0.50  $\Omega$ , 1.08 mH
- Interface Impedance: 3  $\Omega$ , 28.6 mH
- Load: 400 kW, 180 kVar

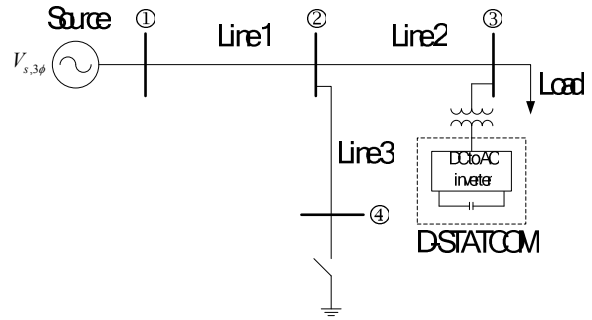

Fig. 6 Simplified 4-bus test system

The test is carried out by assuming a three-phase fault at bus 4. The fault started at  $t = 0.1$  s.

#### A. Base Case

The base case is the system without any compensation. D-STATCOM is not installed for this case. The results of the base case are worst. It results in the balanced load voltage of bus 3 as shown in Figs. 7 and 8, for the  $abc$  and  $0dq$  references, respectively. Also, the source current is remarkably increased to supply the short-circuit current through bus 4 as shown in Fig. 9. With this situation, the supply source is normally isolated by operation of a set of protective equipment in the system. It causes service interruption to a customer at bus 3.

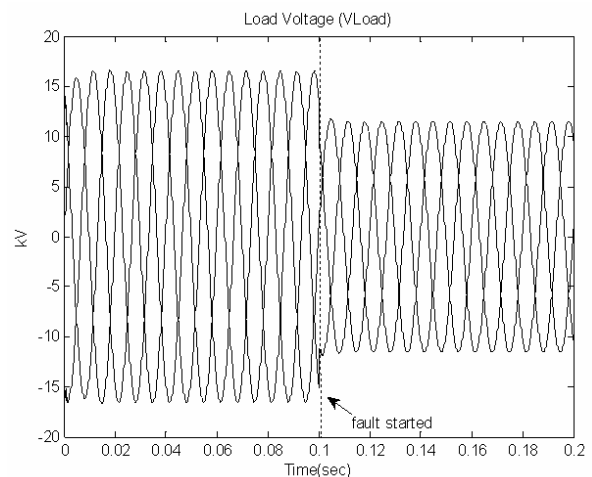

Fig. 7 Load voltages in the  $abc$  reference at bus 3

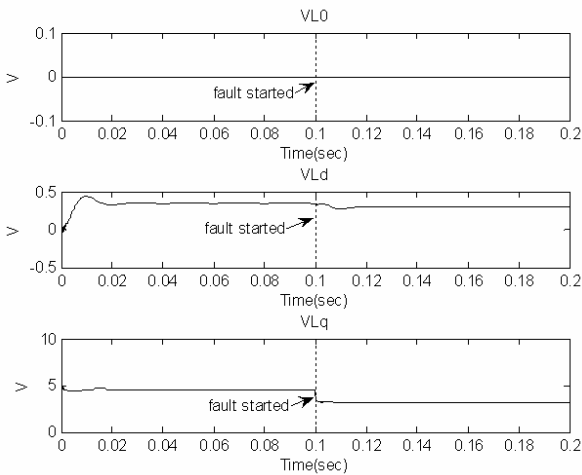

Fig. 8 Load voltages in the  $0dq$  reference at bus 3

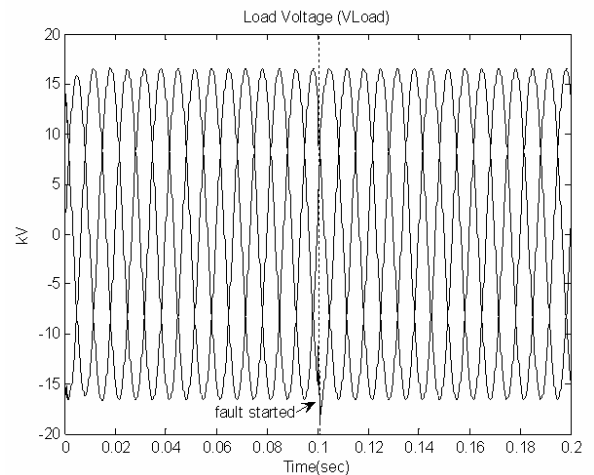

Fig. 11 Variation of the  $abc$  components of the load voltage

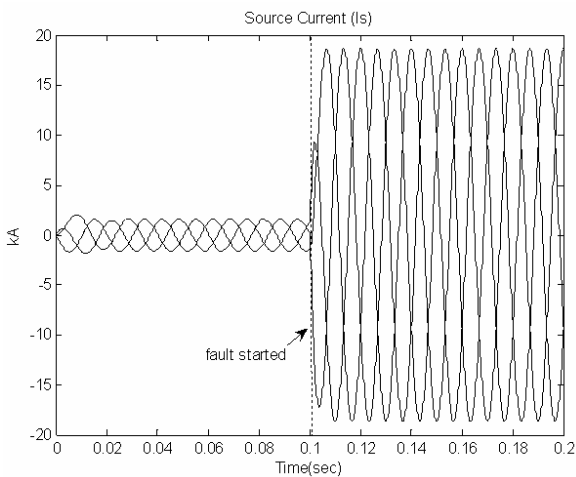

Fig. 9 Source currents of the base case

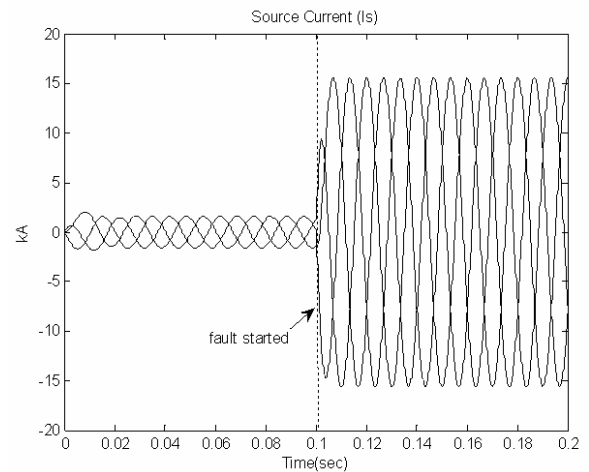

Fig. 12 Source currents of the D-STATCOM case

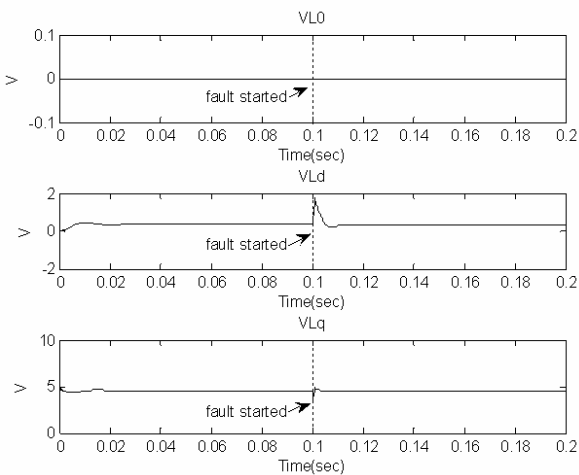

Fig. 10 Variation of the  $0dq$  components of the load voltage

**B. D-STATCOM Case**

With the presence of D-STATCOM, the load voltage at bus 3 can be compensated by the injecting current from the D-STATCOM. When the fault occurs at  $t = 0.1$  s, the load voltage is sagged suddenly due to the fault current flowing through the faulted bus. With the help from the D-STATCOM, the load voltage can be resumed to its desired level within 1.8 ms. Figs 10-11 show variation of the  $0dq$  and  $abc$  components of the load voltage under the fault test. Unlike the base case, the source current as shown in Fig. 12 is reduced by 5-kA of the peak comparative with that of Fig. 9 due to the fault event.

**VI. CONCLUSION**

The voltage control scheme of D-STATCOM to regulate the load voltage under three-phase faults is described in this paper. Its voltage detection and voltage regulation schemes are working in the  $0dq$  reference. The proposed control strategy simply employs the proportional controller in which the proportional gain,  $k_p$ , is tuned by using genetic algorithms. A simple 4-bus test system with the three-phase fault at bus 4 is used for test. As a result, the D-STATCOM can regulate the load voltage to the desired level as fast as 1.8 ms. This

confirms that the proposed voltage regulation scheme performs well under the three-phase fault event.

#### REFERENCES

- [1] S.M. Woo, D.W. Kang, W.C. Lee, and D.S. Hyum, "The Distribution STATCOM for Reducing the Effect of Voltage Sag and Swell", *IECON'01*, vol. 2, pp. 1132-1137, 2001.
- [2] S.Y. Park and J.K. Park, "The Modeling and Analysis of Shunt type Custom Power Device", *IEEE Power Engineering Society Winter Meeting*, vol. 1, pp. 186 - 191, 2001.
- [3] H.K. Chiang, B.R. Lin, K.T. Yang, and C.C. Yang, "Analysis and Implementation of a NPC-Based DSTATCOM under the Abnormal Voltage Condition", *Industrial Technology 2005, International Conference on*, pp. 665 – 670, December 2005.
- [4] H. Saadat, *Power system analysis*, McGraw-Hill, Singapore, 2004.
- [5] G.F. Franklin, J. D. Powell, and M. Workman, *Digital control of dynamic systems*, Wesley, 1998.
- [6] D. E. Goldberg, and D. Edward, *Genetic Algorithms in Search, Optimization and Machine Learning*, Wiley, 1989.
- [7] T. Charuwat and T. Kulworawanichpong, "Genetic based distribution service restoration with minimum average energy not supplied", *The 8<sup>th</sup> International Conference on Adaptive and Natural Computing Algorithms (ICANNGA2007)*, pp. 230-239, April 2007.
- [8] M. Rashidi, F. Rashidi and H. Monavar, "Tuning of power system stabilizers via genetic algorithm for stabilization of power system", *IEEE Int. Conf. Systems, Man and Cybernetics*, vol. 5, pp. 4649 – 4654, October 2003.
- [9] The MathWorks Inc., *MATLAB<sup>®</sup> The language of technical computing*, CD-ROM Manual, 2004.
- [10] The MathWorks Inc., *Genetic Algorithms and Direct Search TOOLBOX*, CD-ROM Manual, 2004.