

# Design and Calculation of 75W Three-phase Linear Switched Reluctance Motor

Mr. Myo Min Thet

Department of Electrical Power Engineering, Mandalay Technological University, Myanmar  
myominthet007@gmail.com

**Abstract**— Switched reluctance machines are generally similar to series-excited DC and synchronous reluctance machines. A switched reluctance motor (SRM) has field winding on the stator but no field coils or magnets on the rotor. Linear Switched Reluctance Motor (LSRM) is an SRM of unrolling stator and rotor into a plane. An LSRM has a doubly salient magnetic circuit with a polyphase winding on the armature. LSRMs are mostly used in the field of direct-drive linear motion systems.

Differing from other linear motors, LSRM is simple in construction, less expensive, very suitable for high-speed travel over long distances, more robust and more fault tolerant. Since mechanical couplings, lead screws, magnets, and brushes are not required in LSRM, special mechanical adjustments and alignments are not necessary. Thus, LSRM is superior to other linear motors.

For the above mentioned attraction, a three-phase LSRM with active stator and passive translator (mover) structure is designed and calculated in this paper. The LSRM model has 5m long stator and 75 W rated power for one stator sector. It is considered on the high speed of 1.5 m/s for the application of conveyor in factory horizontal transportation systems. Firstly, the desired specifications of LSRM are changed into equivalent rotary SRM specifications. Secondly, the rotary SRM is designed. Thirdly, the LSRM dimensions and design variables are obtained by inverse translation. Finally, the design is satisfied with the fact that the length of one sector of the stator must be equal that of the translator.

**Keywords**— Linear Motion, Linear Switched Reluctance Motor, Rotor, Stator, Three-phase

## I. INTRODUCTION

The name switched reluctance has now become the popular term in the technical literature. SRMs are alternatively known as variable reluctance motors (VRMs), reflecting the origins of the technology being derived from variable reluctance stepper motors. Variable reluctance machines are often referred to as SRMs to indicate the combination of a

VRM and the switching inverter required to drive it. The SRM technology is now successfully penetrating into the industry with the promise of providing on efficient drive system at a lower cost.

Switched Reluctance Machine has been under attention of researchers in the last three decades. The technological progress, particularly in the field of electronics and informatics, stimulate the development of new and better solutions to improve its performance.

Its modelling presents important difficulties and its control is not yet a perfect art. However, SRM drives have been found competitive with traditional AC and DC drives due to the simple construction and fewer power converter requirements. In comparison to the other types of linear motor, linear SRM (LSRM) serves many advantages that other actuators do not have. The proposed actuator for LSRM has a much simpler structure and is less expensive. It is also more robust and more fault tolerant, and has less overheating problem. So it is a potential candidate for high performance linear motion drive.

## II. BASIC CONSTRUCTION OF SRM

Switched reluctance motors have saliency in both stator and rotor and so they are the simplest electric motors in construction. The stator and rotor are usually both made of laminated silicon steel in order to diminish eddy currents. The stator has independent windings with excitation field coils on its poles whereas the rotor is solid laminated and has no coils or permanent magnets on it. Hence the SRM is denoted as a doubly-salient, singly-excited machine. A typical switched reluctance motor is shown in Fig. 1.



Fig. 1 A typical switched reluctance machine

The stator windings on diametrically opposite poles are connected in series or parallel to form one face of motor. Generally, the number of stator poles is greater than that of rotor poles. Some possible combinations are 6/4 (six stator poles and four rotor poles), 8/4, 8/6, 10/6, 12/10, etc. The larger the number of stator and rotor poles, the less the torque ripple. By choosing a combination where there are two more stator poles than rotor poles, high torque and low switching frequency of the power converter can be achieved. The three-phase 6/4 SRM and the four-phase 8/6 SRM are typically used. Stator and rotor configurations of the SRMs are shown in Fig 2.

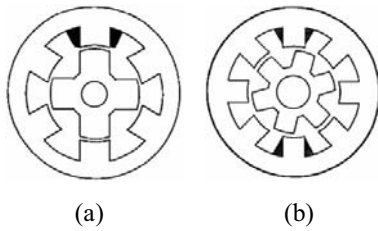

Fig. 2 Stator and rotor configurations of an SRM

- (a) Three-phase 6/4 SRM  
(b) Four-phase 8/6 SRM

### III. BASIC OPERATION OF LINEAR SRM

Operation of the LSRM is based on the inductance profile of the machine. The inductance of the machine is related to machine dimensions such as the stator and translator pole and slot widths, excitation currents, and rotor position. Assuming the magnetic circuit is linear and therefore the inductance characteristics are independent of stator current excitation. A relationship between the machine dimensions and inductance is shown in Fig 3.

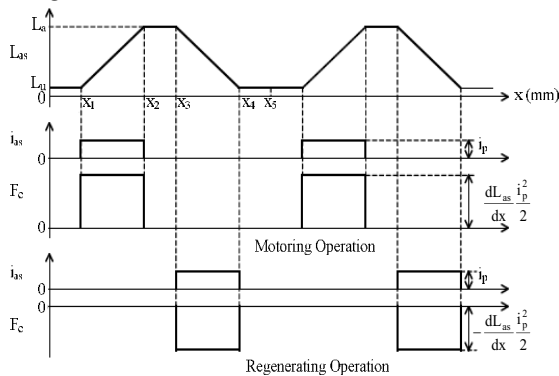

Fig. 3 Inductance and force generation for linear SRM

Five translator positions are necessary to derive the inductance profile:

$$x_1 = \frac{w_{ts} - w_{sp}}{2} \quad (1)$$

$$x_2 = x_1 + w_{sp} = \frac{w_{ts} + w_{sp}}{2} \quad (2)$$

$$x_3 = x_2 + (w_{tp} - w_{sp}) = w_{tp} + \left( \frac{w_{ts} - w_{sp}}{2} \right) \quad (3)$$

$$x_4 = x_3 + w_{sp} = w_{tp} + \left( \frac{w_{ts} + w_{sp}}{2} \right) \quad (4)$$

$$x_5 = x_4 + \frac{w_{ts} - w_{sp}}{2} = w_{tp} + w_{ts} \quad (5)$$

where  $w_{tp}$  = width of the translator pole

$w_{ts}$  = width of the translator slot

$w_{sp}$  = width of the stator pole

$w_{ss}$  = width of the stator slot

Between  $x_2$  and  $x_3$ , there is complete overlap of the stator and translator poles, and inductance during this interval corresponds to the aligned value and is a maximum. As there is no change in the inductance in this region, zero force is generated with an excitation current in the winding. But, it is important to have this flat inductance region to give time to commutate the current and prevent the generation of a negative force. The unequal stator and translator pole widths contribute to the flat-top inductance profile. On the other hand, the regions corresponding to  $0 \sim x_1$  and  $x_4 \sim x_5$  have no overlap between the stator and translator poles. These positions have the minimum phase inductance, known as unaligned inductance. The rate of change of inductance is zero; hence these regions also do not contribute to force production.

The force production for motoring and regeneration is shown in Fig. 4. The forward direction of motion of the translator is assumed to be positive when the phase excitation sequence is abc. For forward direction of motion, regions I to III represent forward motoring operation and regions IV to VI represent forward regenerative operation for the phase sequence abc. Similarly, for reverse direction of motion, regions I to III represent reverse regenerative operation and regions IV to VI represent reverse motoring operation for the phase sequence acb. The duty cycle of each phase is only 1/3, and the induced emfs are constant between  $x_2$  and  $x_1$ .

The air gap power and  $P_{ar}$  represents the regenerative air gap power.  $F_{em}$  is the motoring force and  $F_{er}$  is the regenerative force. One half of the air gap power is stored in the form of magnetic field energy in phase windings and the other half of the air gap power is converted to mechanical power output. Ideal inductance profiles and ideal current generation are assumed, but ideal currents with step rise and fall are not feasible due to the machine inductance; therefore, compensation to obtain the desired current is achieved by advancing the energization of the windings.

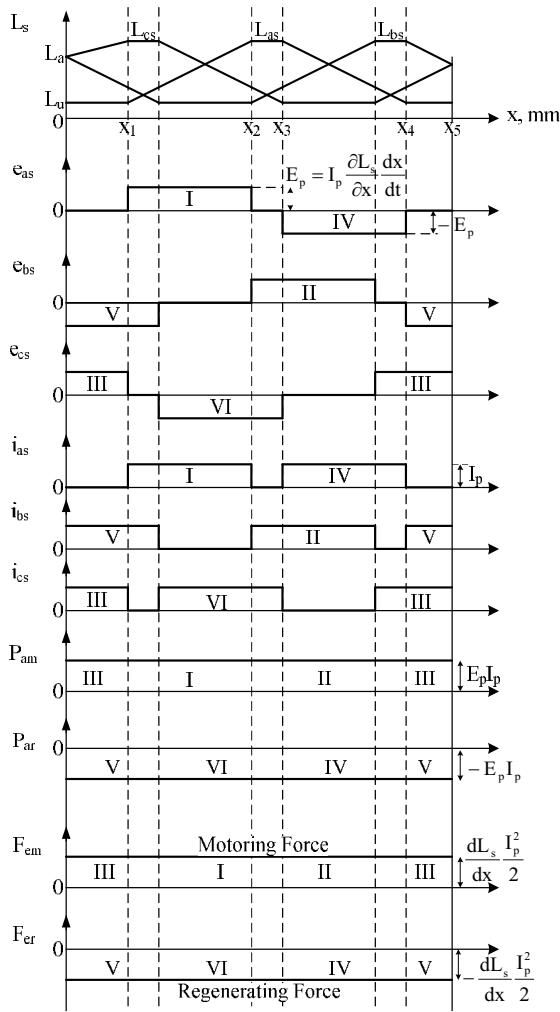

Fig. 4 Operation of a three-phase linear SRM

IV. DESIGN PROCEDURE

The proposed design procedure utilizes the rotating switched reluctance machine (rotary SRM) design by converting the specifications of the linear machine into those of an equivalent rotating machine. The machine design is carried out in the rotary section, which then is transformed back into the linear section. A standard or classical design procedure begins with the power output equation relating the machine dimensions such as bore diameter, lamination stack length, speed, magnetic loading, and electric loading. Further, the machine dimensions and their impact on performance are characterized by implicit relationships and made available in a form to enable machine design.

Analytical expressions relation machine dimensions to output variables are required for a linear SRM design. If a standard design procedure is available for the rotary SRM, the design of an LSRM can proceed via the rotary SRM if the design specifications can be transformed from the linear to rotary domain, and the design is then carried out in the rotary domain. The specifications can be recovered in the linear

domain by simple algebraic transformations.

V. CONFIGURATION OF THREE-PHASE LSRM DESIGN

The longitudinal LSRM configuration of a three-phase LSRM with an active stator and passive translator is designed in this paper.

Fig. 5 shows the three-phase LSRM structure and its winding diagram with an active stator, a passive translator, and a longitudinal flux configuration. The LSRM consists of six translator poles and n stator poles. This corresponds to the six stator and four rotor pole rotary SRM. One stator sector is composed of six stator poles, and the number of stator sectors the number of stator sectors  $N_{sc}$  is given by:

$$N_{sc} = \frac{n}{6} \tag{6}$$

A rotary SRM has four rotor poles; hence the corresponding LSRM should have four translator poles. However, in the LSRM structure with four translator pole there is a reversal of flux at the instant of phase current commutation. Three-phase LSRM which has only four translator poles is shown in Fig. 6.

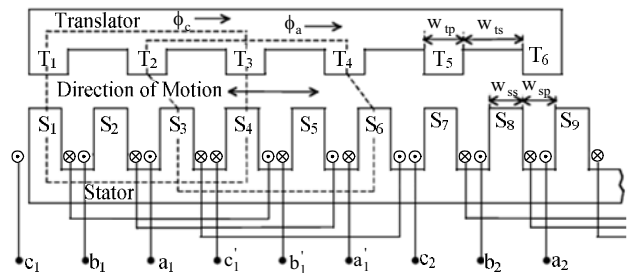

Fig. 5 Three-phase LSRM with six translator poles

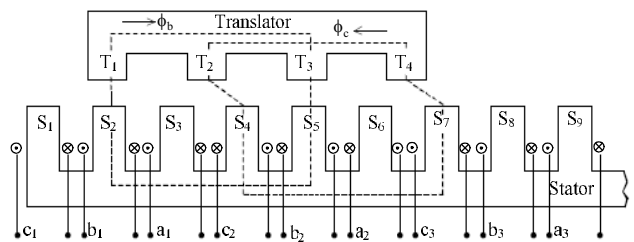

Fig. 6 Three-phase LSRM with four translator poles

VI. DESIGN CALCULATION OF A THREE-PHASE LSRM WITH ACTIVE STATOR AND PASSIVE TRANSLATOR

An LSRM configuration is designed for the following specifications.

- Length of LSRM = 5 m
- Maximum linear velocity = 1.5 m/s
- Acceleration time = 0.6 s
- Maximum mass of translator assembly = 20 kg

The acceleration is

$$a_a = \frac{v_m}{t_a} = \frac{1.5}{0.6} = 2.5 \text{ m/s}^2$$

The force for initial acceleration is calculated as:

$$F_a = M_t a_a = 20 \times 2.5 = 50 \text{ N}$$

Deceleration,  $a_d = -a_a = -2.5 \text{ m/sec}^2$

Deceleration force,  $F_d = -F_a = -50 \text{ N}$

Power capacity of the LSRM,  $P = F_a v_m = 50 \times 1.5 = 75 \text{ W}$

After calculating the specification of LSRM, the design of rotary SRM is continued using the above calculated data.

For continuous starting torque, the minimum stator pole arc is chosen. Therefore, it can be calculated as follow.

$$\min[\beta_s] = \frac{4\pi}{P_s P_r} = \frac{4\pi}{6 \times 4} = 30^\circ = 0.5236 \text{ rad}$$

Since  $\beta_r > \beta_s$ , the value of  $\beta_r$  is chosen as  $36^\circ$ . Therefore,

Stator pole angle of rotary SRM,  $\beta_s = 30^\circ = 0.5236 \text{ rad}$

Rotor pole angle of rotary SRM,  $\beta_r = 36^\circ = 0.6283 \text{ rad}$

Then to get the maximum power developed, current conduction angle  $\theta_i$  must be equal to stator pole arc  $\beta_s$ .

$$k_d = \frac{\theta_i \times q P_r}{360} = \frac{30 \times 3 \times 4}{360} = 1$$

$$k_2 = 1 - \frac{L_u}{L_a^s}$$

For the constant,  $k_2$ , it needs to be calculated maximum stator current to extract the maximum output power. For that matter, the magnetic characteristics of the steel core material gives the ratio of  $L_u$  to  $L_a^s$ , 0.3. Therefore

$$k_2 = 1 - 0.3 = 0.7$$

For steel core lamination,  $B = 1.13 \text{ T}$  and  $A_s = 24400$

For non-servo application,  $k$  is chosen as 0.65.

After fine-tuning the parameters, the constants are as follows:

$$k_e = 0.4, k_d = 1, k_1 = \frac{\pi^2}{120}, k_2 = 0.7, B = 1.13 \text{ T}, A_s = 24400, \text{ and } k = 0.65$$

Then, the bore diameter is evaluated as follow.

$$D = \sqrt{\frac{P\pi}{60 \times k_e k_d k_1 k_2 k B A_s v_m}}$$

$$= \sqrt{\frac{75 \times \pi}{60 \times 0.4 \times 1 \times \frac{\pi^2}{120} \times 0.7 \times 0.65 \times 1.13 \times 24400 \times 1.5}}$$

$$= 0.0796444 \text{ m} \approx 80 \text{ mm}$$

Speed of the rotary SRM is

$$N_r = \frac{v_m}{D/2} \times \frac{60}{2\pi} = \frac{1.5 \times 10^3}{40} \times \frac{60}{2\pi} = 358.1 \approx 360 \text{ rpm}$$

Switching frequency in phase winding for LSRM is

$$f_{sw} = 2P_r \frac{N_r}{60} = 2 \times 4 \times \frac{360}{60} = 48 \approx 50 \text{ Hz}$$

The pole pitch of LSRM is

$$\tau = \frac{v}{f_{sw}} = \frac{1.5}{50} = 30 \text{ mm}$$

The stack length of the rotary SRM is

$$L = kD = 0.65 \times 80 = 52 \text{ mm}$$

The stator yoke thickness  $b_{sy}$  is calculated as

$$b_{sy} = \frac{D\beta_s}{2} = \frac{80 \times 0.5236}{2} = 20.944 \approx 21 \text{ mm}$$

Assuming the stator outer diameter,  $D_o = 200 \text{ mm}$ , the height of the stator pole,  $h_s$  can be calculated.

$$h_s = \frac{D_o}{2} - \frac{D}{2} - b_{sy} = \frac{200}{2} - \frac{80}{2} - 21 = 39 \text{ mm}$$

The rotor back iron width,  $b_{ry}$ , and the height of the rotor pole (translator pole),  $h_r$  are calculated as:

$$b_{ry} = \left(\frac{D}{2}\right)\beta_r = \left(\frac{80}{2}\right) \times 0.6283 = 25.132 \approx 25 \text{ mm}$$

$$h_r = \frac{D}{2} - \lambda_g - b_{ry} = \frac{80}{2} - 1 - 25 = 14 \text{ mm}$$

The magnetic field intensity in the air gap is calculated as:

$$H_g = \frac{B}{\mu_0} = \frac{1.13}{4\pi \times 10^{-7}} = 899,225.43 \text{ A/m} = 899.2254$$

A/mm

For a peak phase current of  $I_p = 9 \text{ A}$  allowable in the machine, the number of turns per phase is

$$T_{ph} = \frac{H_g (2\lambda_g)}{I_p} = \frac{899.2254 \times (2 \times 1)}{9} = 199.83 \approx 200$$

turns/phase

Assuming a current density of  $J = 6.4 \text{ A/mm}^2$ , the area of the conductor is

$$a_c = \frac{I_p}{J\sqrt{q}} = \frac{9}{6.4\sqrt{3}} = 0.812 \text{ mm}^2$$

Therefore, the closest wire size chosen from Table II (APPENDIX) for this cross sectional area of the conductor is SWG 19. It has an area of  $0.8171 \text{ mm}^2$  and is selected for the phase windings. The calculation of the winding turns complete the rotary SRM design.

Now, the conversion from the rotary to the linear domain is calculated as follow.

The number of sectors of the LSRM and the resultant total number of stator poles are

$$N_{sc} = \frac{L_t}{\pi D} = \frac{5}{\pi \times 80 \times 10^{-3}} = 19.8944 \approx 20$$

$$n = P_s N_{sc} = 6 \times 20 = 120$$

In the active stator and passive translator structure of LSRM, the stator and rotor of the rotary SRM correspond to the stator and translator of LSRM respectively.

The width of the stator pole and the width of the stator slot are obtained as:

$$w_{sp} = b_{sy} = \frac{D\beta_s}{2} = \frac{80 \times 0.5236}{2} = 20.944 \approx 21 \text{ mm}$$

$$w_{ss} = \frac{(\pi D - P_s w_{sp})}{P_s} = \frac{(\pi \times 80 - 6 \times 21)}{6} = 20.889 \approx 21 \text{ mm}$$

The width of the translator pole and the width of the translator slot are calculated as:

$$w_{tp} = b_{ry} = 25 \text{ mm}$$

$$w_{ts} = \frac{(\pi D - P_r w_{tp})}{P_r} = \frac{(\pi \times 80 - 4 \times 25)}{4} = 37.8319 \approx 38 \text{ mm}$$

Since the LSRM designed has six translator poles, the total length of the translator is

$$L_{tr} = 6w_{tp} + 5w_{ts} = 6 \times 25 + 5 \times 38 = 340 \text{ mm}$$

The core stack width of the LSRM is obtained from the stator stack length of the rotary SRM as:

$$L_w = L = kD = 0.65 \times 80 = 52 \text{ mm}$$

The fill factor of the windings must be calculated to verify that the slot size is sufficient to hold the windings.

The diameter of the conductor is

$$d_c = \sqrt{\frac{4a_c}{\pi}} = \sqrt{\frac{4 \times 0.8171}{\pi}} = 1.02 \text{ mm}$$

Assuming the width of the wedges  $w = 3$  and packing factor  $P_f = 0.8$ , the number of vertical layers of the winding is

$$N_v = P_f \frac{(h_s - w)}{d_c} = 0.8 \times \frac{(39 - 3)}{1.02} = 28.2353 \approx 28$$

and the number of horizontal layers of winding is

$$N_h = \frac{T_{ph}}{2 \times N_v} = \frac{200}{2 \times 28} = 3.5714 \approx 4$$

The winding area is given by

$$\text{Stator winding area} = 2 \frac{a_c N_v N_h}{P_f}$$

$$= 2 \times \frac{0.8171 \times 28 \times 4}{0.8} = 228.788 \text{ mm}^2$$

Stator slot window area =  $w_{ss}(h_s - w) = 21 \times (39 - 3) = 756 \text{ mm}^2$

The fill factor is calculated as:

$$F_f = \frac{\text{Stator winding area}}{\text{Stator slot window area}} = \frac{228.788}{756} = 0.30263$$

It is in the normal range of  $0.2 \leq F_f < 0.7$ .

Then it has to be proved that the following two Equations are equal.

$$P_s(w_{sp} + w_{ss}) = 6 \times (21 + 21) = 252$$

$$P_r(w_{tp} + w_{ts}) = 4 \times (25 + 38) = 252$$

Finally, it is observed that the above Equation is satisfied with the LSRM design. The dimensions of the designed three-phase LSRM is shown in Fig. 7. The calculated design parameters of the LSRM are summarized as follow (Table I).

TABLE I  
DATA SHEET OF CALCULATED DESIGN PARAMETERS

No	Design Parameter	Calculated Value
1	Length of LSRM	5 m
2	Linear Velocity	1.5 m/s
3	Mass of Translator Assembly	20 kg
4	Acceleration	2.5 m/s <sup>2</sup>
5	Power Capacity for a Stator Sector	75W
6	Number of Stator Sectors	20
7	Total Number of Stator Poles	120
8	Width of Stator Pole	21 mm
9	Width of Stator Slot	21 mm
10	Width of Translator Pole	25 mm
11	Width of Translator Slot	38 mm
12	Total Length of Translator	340 mm
13	Core Stack Width of LSRM	52 mm
14	Number of Vertical Layers of Winding	28
15	Number of Horizontal Layers of Winding	4

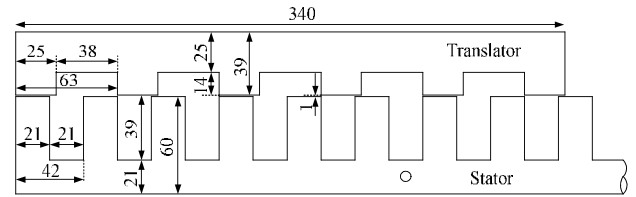

Unit of Dimensions : mm

Stack Width : 52 mm

Coil : SWG 19 and 200 Turns/Phase

Fig. 7 Dimensions of the designed three-phase LSRM

## VII. CONCLUSION

Nowadays, all over the world, the linear SRM is emerging for many applications. Since many movements in production and transportation systems are translatable, LSRMs are useful in these fields. In such motors linear movements are generated directly, so that the lead screws, gear units such as spindle/bolt, gear rack/pinion, belt/chain systems are unnecessary. Hence LSRMs are used to reduce the cost of the system and to make the system compact and highly reliable.

This paper is mainly intended for knowing design consideration and calculation for linear SRM. The increasing demand for linear design of SRMs has made the circle of electrical engineering extremely important and has result in the new, modern and developed nation leading to extend other advanced design technologies in new areas of applications.

## APPENDIX

TABLE II  
STANDARD WIRE GAUGE

SWG	Cross Sectional Area (mm <sup>2</sup> )	Diameter (mm)
0000	81.073	10.16
000	70.12	9.45
00	61.36	8.84
0	53.19	8.23
1	45.60	7.62
2	38.59	7.01
3	32.17	6.40
4	27.25	5.89
5	22.73	5.38
6	18.70	4.88
7	15.69	4.47
8	12.95	4.06
9	10.52	3.66
10	8.296	3.25
11	6.835	2.95
12	5.474	2.64
13	4.3	2.34
14	3.237	2.03
15	2.630	1.83
16	2.086	1.63
17	1.584	1.42
18	1.169	1.22
19	0.8171	1.02
20	0.6567	0.9144
21	0.519	0.813
22	0.3973	0.711
23	0.2922	0.610
24	0.2453	0.5588
25	0.2027	0.508

- [6] Kaw Krishnan, R. 2001. Switched Reluctance Motor Drives: Modelling, Simulation, as Analysis, Design, and Applications. ak U.S.A. CRC Press LLC.
- [7] Lee, B.S., Bae, H.K., Vijayraghavan, P. and Krishnan, R. 1999. "Design of a Linear Switched Reluctance Machine", Conference of IEEE Industry Appl. J Soc. (IAS '99), vol. 1, (October): 547-554.
- [8] Miller, T.J.E. 1993. Switched Reluctance Motors and Their Control. Magna Physics Publishing and Clarendon Press, Oxford, UK.
- [9] Miller, T.J.E. 2002. "Optimal Design of Switched Reluctance Motors". IEEE Transactions on Industrial Electronics, 49, no.1 (February): 15-26.
- [10] R. Randun, A.V., 1995. "Design Considerations for the Switched Reluctance Motor". IEEE Transactions on Industry Applications, 31, 1049-1087.
- [11] Yuan, G. 2000. "Speed Control of Switched Reluctance Motors". M.Phil. Thesis, E. The Hong Kong University of Science and Technology, Hong Kong.
- [12] <http://home.datacomm.ch/hb9abx>

## ACKNOWLEDGMENT

The author wishes to acknowledge Dr. Myo Myint Aung , Assistant Professor, Head of Department of Electrical Power Engineering, Mandalay Technological University, for his kind permission, providing encouragement and giving helpful advices and comments. Special thanks are also owed to Dr. Ni Ni Win, Assistant Professor, Department of Electrical Power Engineering, Mandalay Technological University, for thoroughly proof-reading this paper and giving useful remarks on it.

## REFERENCES

- [1] Amanda, M.S. 2001. "Design and Implementation of A Novel Single-phase Switched Reluctance Motor Drive System". M.Sc. Thesis, Virginia Polytechnic Institute and State University, Blacksburg, Virginia.
- [2] Arreola, R.B. 2003. "Nonlinear Control Design for a Magnetic Levitation System". M.Sc. Thesis, University of Toronto, Canada.
- [3] Gan, W.C. and Cheung, N.C. 2001. "Design of a Linear Switched Reluctance Motor for High Precision Applications," IEEE International Electric Machines and Drives Conference, June 2001.
- [4] Gieras, J.F. and Piech Z.J. 2000. Linear Synchronous Motors: Transportation and Automation Systems. U.S.A. CRC Press LLC.
- [5] Henneberger, H.C.G. 2002. Electrical Machines I: Basics, Design, Function, and Operation. Lecture Script, Aachen University, Germany.