

Cardiac Disorder Classification Based on Extreme Learning Machine

Chul Kwak, Oh-Wook Kwon

Abstract—In this paper, an extreme learning machine with an automatic segmentation algorithm is applied to heart disorder classification by heart sound signals. From continuous heart sound signals, the starting points of the first (S1) and the second heart pulses (S2) are extracted and corrected by utilizing an inter-pulse histogram. From the corrected pulse positions, a single period of heart sound signals is extracted and converted to a feature vector including the mel-scaled filter bank energy coefficients and the envelope coefficients of uniform-sized sub-segments. An extreme learning machine is used to classify the feature vector. In our cardiac disorder classification and detection experiments with 9 cardiac disorder categories, the proposed method shows significantly better performance than multi-layer perceptron, support vector machine, and hidden Markov model; it achieves the classification accuracy of 81.6% and the detection accuracy of 96.9%.

Keywords—Heart sound classification, extreme learning machine

I. INTRODUCTION

HEART diseases are critical and should be detected as soon as possible. Physicians require hard training to diagnose heart disorders by inspecting the heart sounds from a stethoscope. Consequently, an automatic heart-disorder classification system would help physicians diagnose heart disorders and discern the necessity of close diagnosis.

A heart has four chambers. The upper two are the right and left atria. The lower two are the right and left ventricles. Blood is pumped through the chambers, aided by four heart valves. A period of the heart sound signals makes up the sequence of S1-systole-S2-diastole intervals. The heart murmur and click sound is a cue to detect heart disorders. The abnormal heart sounds have the murmur or click sound in the systole and diastole intervals, but the normal heart sounds do not.

Previously, artificial neural networks (ANNs) [1]-[3] and hidden Markov models (HMMs) [4], [5] have been used as the automatic classification method for the heart sound signal. An ANN-based classification system has an automatic segmentation algorithm as a preprocessing step in order to segment a period of heart sound signals and extract a feature vector for classification. But the errors in the segmentation algorithm often lower classification accuracy. On the other hand, an HMM-based classification system works for continuous

heart sound signals of multiple periods as well as one period, but it has poor discrimination power compared to ANN-based systems.

In this work, we modify the automatic segmentation algorithm to reduce the segmentation errors and use an extreme learning machine (ELM) [6] to improve the accuracy of pattern classification. By using the improved automatic segmentation algorithm and the ELM-based classifier, we not only reduce the classification time, but also improve the classification accuracy significantly.

II. ELM-BASED CLASSIFICATION OF HEART SOUND SIGNALS

The proposed heart sound classification system is shown in Fig. 1. From the continuous heart sound signals, the starting points of S1 and S2 intervals are found. After correcting the S1/S2 pulse positions, we obtain a single period of heart sound signals and extract a feature vector. The ELM-based classifier decides the category of cardiac disorders.

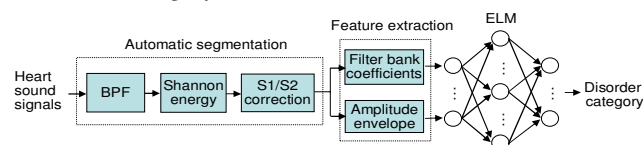

Fig. 1 The ELM-based heart sound classification system.

A. Automatic Segmentation

An example of S1/S2 starting-point extraction is shown in Fig. 2. Because the frequency principal ingredients of S1/S2 exist in between 50~100 Hz, we apply band-pass filtering (BPF) to reduce the heart murmur, as shown in Fig. 2(b). Input signals are normalized and blocked into frames with the shift size of 20 ms and the Hamming window size of 40ms. Figure 2(c) shows the Shannon energy [7] of each frame. Then, a decision threshold is computed by the image binarization method [8] and multiplied by 10 so that S1/S2 intervals can be detected whereas murmur sound is suppressed. In Fig. 2(d), dotted lines indicate S1/S2 sections whose Shannon energy is larger than the decision threshold. Finally the starting points of the S1/S2 sections are marked as a pulse as shown in Fig. 2(e).

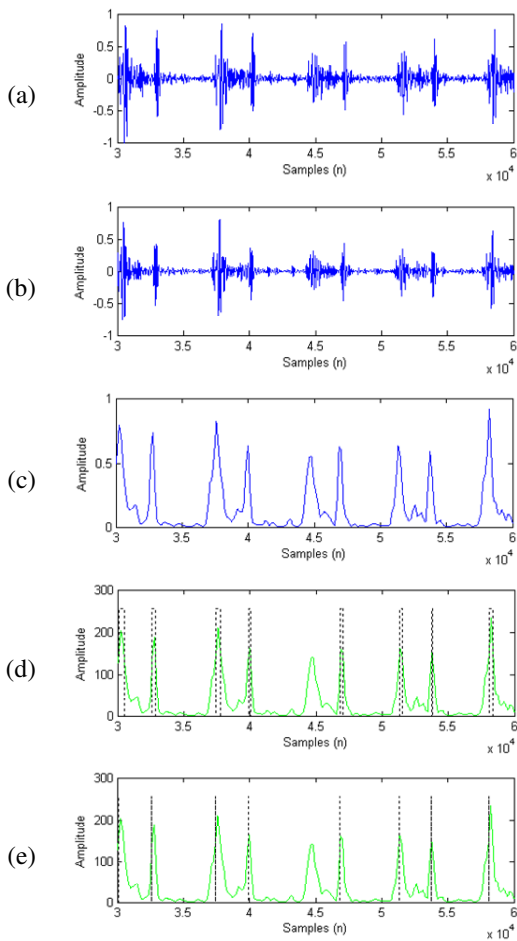

Fig. 2 An example of S1/S2 starting-point extraction. (a) The input signal, (b) band-pass filter output signals, (c) Shannon energy, (d) S1/S2 intervals, and (e) the starting-points of S1/S2 intervals.

The procedure of starting-point correction is shown in Fig. 3. First, a histogram of inter-pulse duration is obtained from the pulse sequence obtained in the previous procedure. Considering the fact that the duration from S1 to S2 pulses (S1→S2) is shorter than that from S2 to S1 pulses (S2→S1), we compute the average S1→S2 duration (D1) by using the samples below 50 percentile. A pair of pulses whose inter-distance is near the average S1→S2 duration is labeled as S1 and S2. The average S2→S1 duration (D2) is computed from the second peak of the histogram of inter-pulse duration.

The type of unlabeled pulses (marked as 'X') is determined by comparing the distance from S2 to 'X' (L2) and the distance from 'X' to S1 (L1) as shown in Fig. 3(c). In the figure, the unlabeled pulse is determined as S2 since $|L1 - D2|$ is less than $|L2 - D2|$. Finally missing pulses or incorrect pulses are corrected by utilizing D1 and D2. Fig. 3(d) shows that S1 is added in this case. In a very rare case when two consecutive periods do not have any S1/S2 pulses, S1/S2 pulses are inserted by considering D1 and D2 sequentially from either side. After correcting through S1/S2 pulses, we extract only a single period of heart sound signals.

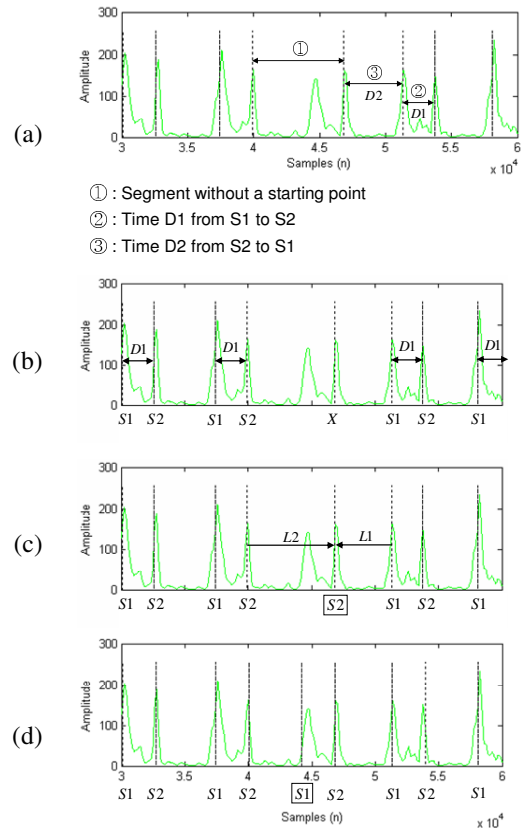

Fig. 3 Procedure of starting-point correction. (a) Inter-pulse duration has 3 different kinds. (b) Starting points of S1/S2 pulses are labeled. (c) Unlabeled pulses are resolved. (d) Missing or incorrect pulses are corrected.

B. Feature Extraction

The feature extraction for ELM-based classifier is shown in Fig. 4. The S1 and S2 pulses of heart sound signals have most of energy between the 50 Hz and 200 Hz, and the murmurs below 1 kHz. Hence, we convert the sampling rate down to 2 kHz for feature extraction. Because the heart sound signals repeat similar waveforms periodically, we use only a single period of heart sound signals (frame) in order to extract a feature vector. After applying the Hamming window on a frame, we take the 2,048-point fast Fourier transform (FFT) because a single period is generally below 1s. We compute the log energy values of 100 mel-scaled filter banks [5]. In parallel, we partition the frame into 40 uniform-length sub-segments which is computed the envelope value for each sub-segment. Hence, we obtain the final feature vector of 140 coefficients.

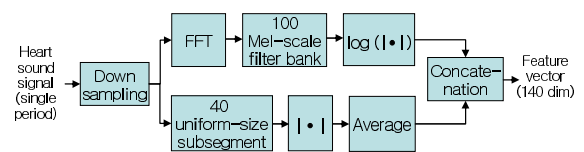

Fig. 4 Feature extraction for ELM-based classifier.

C. ELM-Based Classification

The ELM is a recent neural network algorithm, which is

known to achieve good performance in complex problems as well as reduce the computation time compared with other machine learning algorithms [6]. The ELM algorithm does not train the input weights or the biases of neurons, but it acquires the output weights by using the norm least-squares solution and Moore-Penrose inverse of a general linear system [6]. By finding the node giving the maximum output value, we decide the final result. A simple learning method for the ELM with a single hidden layer can be summarized as follows:

Algorithm ELM: Given a training set $\mathfrak{X} = \{(x_i, t_i) \mid x_i \in R^n, t_i \in R^m, i = 1, \dots, N\}$ where x_i is a training sample and t_i is the corresponding target value, the activation function $g(x)$, and the number of hidden neurons \tilde{N} , perform the following steps.
 Step 1: Assign arbitrary input weight w_{ji} and bias b_i , $j = 1, \dots, \tilde{N}$.

Step 2: Calculate the output matrix at the hidden layer

$$H = g(\mathbf{w} \cdot \mathbf{x} + \mathbf{b})$$

Step 3: Calculate the output weight β .

$$\beta = H^\dagger T$$

Fig. 5 shows the network structure of ELM with a single hidden layer used for our experiments. We used 500 hidden neurons and the sigmoid activation function, and set the number of trials to 1,000.

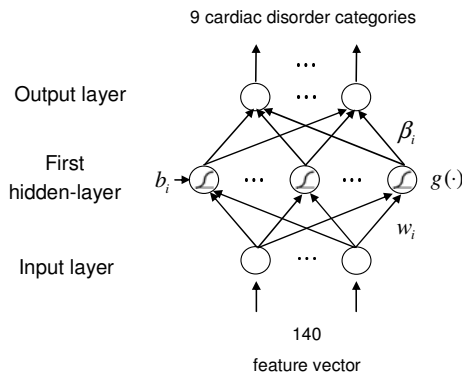

Fig. 5 Structure of ELM network.

III. EXPERIMENTAL RESULTS

A. Database

To evaluate the performance of the proposed algorithm, we used the database which includes two kinds of data. The first one consists of the continuous abnormal heart sound signals extracted from a collection of heart sounds and murmurs [9]. The other includes the normal heart sound signals recorded by using a digital wireless stethoscope developed for this work. The heart sound signals from healthy (normal) persons were supplemented to evaluate the heart disorder detection performance. The database has been recoded in the 8 kHz/16-bit PCM format. The database has labeled with 9 cardiac disorder categories including the normal category. The number of samples was 80 for the normal category and 80 for abnormal categories.

B. ELM-Based Heart Disorder Classification

When the conventional segmentation algorithm is used, the ELM-based classifier showed the average classification accuracy of 79.4%. Because there are a small number of sample data, we used the cross-validation method [13] to measure the classification accuracy. Table II is the classification accuracy of the ELM-based classifier with the new segmentation showing the average classification accuracy of 81.6%. Depending on the cardiac disorders, classification accuracy varied from 44% to 97%.

TABLE I
HEART DISORDER CATEGORIES AND THE NUMBER OF HEART SOUND DATA

Heart sound	The number of heart sound data	
	Continuous	One period
Normal	80	160
AR	6	12
AS	9	18
AR+AS	12	24
Abnormal		
MR	9	18
MS	12	24
MR+MS	5	10
MVP	14	28
VSD	13	26
Average	80	160

AR = Aortic Regurgitation, AS = Aortic Stenosis, AR+AS = Aortic Stenosis & Aortic Regurgitation, MR = Mitral Regurgitation, MS = Mitral Stenosis, MR+MS = Mitral Regurgitation & Mitral Stenosis, MVP = Mitral Valve Prolapse, VSD = Ventricular Septal Defect

TABLE II
CLASSIFICATION ACCURACY OF HEART SOUND DISORDERS

Heart sound	Correct / Sample	Accuracy (%)
Normal	155 / 160	97
AR	6 / 12	50
AS	8 / 18	44
AR+AS	13 / 24	54
Abnormal		
MR	11 / 18	61
MS	19 / 24	79
MR+MS	8 / 10	80
MVP	20 / 28	71
VSD	21 / 26	81
Average	261 / 320	81.6

From the practical viewpoint, a digital stethoscope with the heart disorder detection capability is desirable. Hence, the detection performance of heart disorders was evaluated as shown in Table III. Both the false reject and false alarm rates were 3.1%. This implies that the proposed algorithm can be effectively applied to heart diagnosis by a stethoscope.

TABLE III
DETECTION PERFORMANCE OF CARDIAC DISORDERS

Input	Result	Normal (%)	Abnormal (%)
	Normal		96.9
Abnormal		3.1	96.9

C. Comparison with Other Classifiers

We first performed comparative experiments with the HMM-based classifier [10]. For the HMM-based classifier, we adopted the frame work of a speech recognizer and modified relevant parameters in order to reflect the spectro-temporal characteristics of heart sound signals. The sampling rate was converted to 2 kHz. The shift size was 10 ms and the Hamming window size was 30 ms. The window size was selected so that a frame includes about 3 cycles of the first-harmonic component of S1 and S2 pulse signals. We extracted 12 mel-frequency cepstrum coefficients (MFCCs) and log energy for each frame. By appending the delta features, we have a sequence of 26-dimensional feature vectors. Each disorder category was modeled by an 8-state left-to-right HMM [10] shown in Fig 6(a). The HMM-based classifier showed the average classification accuracy of 72.8%. Then, we modified the topology of the HMM to a circular structure shown in Fig. 6(b) so that it can classify continuous heart sound signals without automatic segmentation. With the circular HMM, the classification accuracy was improved to 75.6%, which is still lower than the ELM-based system.

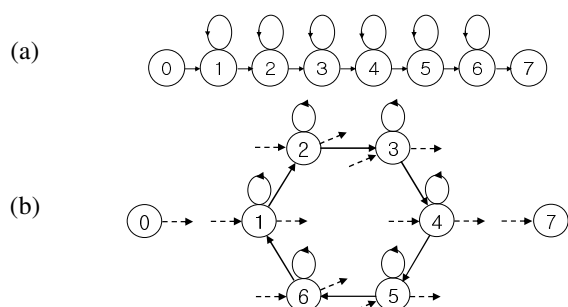

Fig. 6 The structure of (a) the left-to-right and (b) the circular HMMs.

Then, the performance of ELM was compared with the multi-layer perceptron (MLP)-based [11] and the support vector machine (SVM)-based [12] classifiers. These two classifiers used the same feature vector as the ELM-based classifier. The MLP-based classifiers have two hidden-layers which are organized as 100 neurons of the first hidden layer and 20 neurons of the second hidden layer. The MLP network is trained for up to 300 epochs by using the scaled conjugate gradient algorithm with the following parameters: The sigmoid activation function, the learning rate of 0.1, the momentum constant of 0.5, and the error goal of 0.0001.

The SVM-based classifier used the radial-basis function networks (RBFN) kernel and was expanded to multi-class by using one-per-class. The trade-off weight value was set to 500.

The MLP-based and SVM-based classifiers showed the average classification accuracy of 73.1% and 76.6%, which reveals that the ELM-based classifier produces the best accuracy.

Comparing the classification accuracy, the proposed ELM-based classifier improved the classification accuracy by reducing 24.6%, 31.6%, and 21.4% of classification errors compared with circular HMM, MLP, and SVM, respectively. It

also has smaller processing time because a single period is used for classification.

TABLE IV
COMPARISON OF CLASSIFICATION ACCURACY WITH DEFFERENT PATTERN CLASSIFIERS

Heart sound	Accuracy (%)				
	HMM	MLP	SVM	ELM	
Normal	88	96	98	97	
Abnormal	AR	33	33	33	50
	AS	33	44	39	44
	AR+AS	75	54	58	54
	MR	67	50	61	61
	MS	100	63	63	79
	MR+MS	80	50	70	80
	MVP	64	57	57	71
VSD	46	38	58	81	
Average	75.6	73.1	76.6	81.6	

IV. CONCLUSION

We proposed a heart disorder classification system based on automatic segmentation and ELM-based classification. Experimental results showed that the proposed system significantly improves the classification accuracy in classifying 9 cardiac disorder categories compared to HMM-, MLP-, and SVM-based classifiers. These results imply that it can be used as an auxiliary medical tool for initial heart-disease diagnosis by a stethoscope.

REFERENCES

- [1] D. Barschdorff, S. Ester, T. Dorsel, and E. Most, "Neural network based multi-sensor heart sound analysis," *Computers in Cardiology*, pp. 303-306, Sep. 1990.
- [2] O. Abdel-Alim, N. Hamdy, and M. A. El-Hanjouri, "Heart diseases diagnosis using heart sounds," *Proc. 19th NRSC, Alexandria*, pp.19-21, Mar. 2002.
- [3] D. Barschdorff, U. Femmer, and E. Trowitzsch, "Automatic phonocardiogram signal analysis in infants based on wavelet transforms and artificial neural networks," *Computers in Cardiology*, pp. 753-756, 1995.
- [4] M. El-Hanjouri, W. Alkhalidi, N. Hamdy, and O.A. Alim, "Heart diseases diagnosis using HMM," *Proc. IEEE MELECON 2002, Cairo, Egypt*, pp. 489-492, May 2002.
- [5] A. Ricke, R. Provinelli, and M. Johnson, "Automatic segmentation of Heart sound signals using hidden Markov models," *Computer in Cardiology*, 9, pp.953-956, 2005.
- [6] G.-B. Huang, Q.-Y. Zhu and C.-K. Siew, "Extreme learning machine: Theory and applications," *Neurocomputing*, vol. 70, pp. 489-501, 2006.
- [7] H. Liang, S. Lukkarinen, and I. Hartimo, "Heart Sound Segmentation Algorithm Based on Heart Sound Envelopgram," *Computers in Cardiology*, IEEE, vol. 24, pp. 105-108, 1997.
- [8] E.R. Davies, *Machine Vision*, 3rd ed, Elsevier, pp.103-125, 2005.
- [9] Daniel Mason, *Listening to the Heart: A Comprehensive Collection of Heart Sounds and Murmurs*, F. A. Davis Company, Philadelphia, 2000.
- [10] S. Young, et al., *Hidden Markov Model Toolkit v3.4*, Cambridge University, 2006.
- [11] M. Leshno, V. Y. Lin, A. Pinkus, and S. Schocken, "Multilayer feedforward networks with a nonpolynomial activation function can approximate any function," *Neural Networks*, vol. 6, pp. 861-867, 1993.
- [12] Y. Liu and Y.F. Zheng, "One-against-all multi-class SVM classification using reliability measures." *IEEE International Joint Conference on Neural Networks*, vol. 2, pp. 849-854, 2005.
- [13] R.O. Duda, P. E. Hart, and D. G. Stork, *Pattern Classification*, 2nd ed, John Wiley & Sons, Inc, pp. 482-486, 2000.