

# On the Standardizing the Metal Die of Punch and Matrix by Mechanical Desktop Software

First A. M. R. Mosalman Yazdi, Second B. A. R. Mosalman Yazdi

**Abstract**—In industry, one of the most important subjects is die and its characteristics in which for cutting and forming different mechanical pieces, various punch and matrix metal die are used. Whereas the common parts which form the main frame die are not often proportion with pieces and dies therefore using a part as so-called common part for frames in specified dimension ranges can decrease the time of designing, occupied space of warehouse and manufacturing costs. Parts in dies with getting uniform in their shape and dimension make common parts of dies. Common parts of punch and matrix metal die are as bolster, guide bush, guide pillar and shank. In this paper the common parts and effective parameters in selecting each of them as the primary information are studied, afterward for selection and design of mechanical parts an introduction and investigation based on the Mech. Desk. software is done hence with developing this software can standardize the metal common parts of punch and matrix. These studies will be so useful for designer in their designing and also using it has with very much advantage for manufactures of products in decreasing occupied spaces by dies.

**Keywords**— Die, Matrix, Punch, Standardize.

## I. INTRODUCTION

Punch and Matrix die which are used for cutting and forming pieces in different methods have abundant diversity in the cases of shape, dimension and type of them, hence their designing necessitate so much time meanwhile their cost is very much and on the other hand various design of dies more often are used only for one time, thereby these dies will be useless for other cases therefore because of these, warehousing them vastly get increases whereas the occupied space of the warehouses turns to the big problem for manufactures which it needs so much money therefore it seems necessary to use a method to design dies consist of a few parts that be useable in different dies or in the other word, propose a method to make uniformity between common parts of dies.

With using Mech. Desk. Software designer will be able to design so fast and select bolsters, guide pillars, guide bushes and shank with more accuracy.

Advantageous of using Mech. Desk software for selecting common parts of frame are as follows:

- decrease time consuming in stages of selection and

design

- Sooner preparation of drawing the details for fabrication.
- Easy change and correction of drawing with changing the common parts in stages of designing and manufacturing.
- Easy imagination whereas better estimation of casting and machining cost with considering the three dimensional view of elements.

## II. DIE COMMON PARTS

Common part in punch and matrix metal dies consist of many members such top and bottom bolster, guide pillar, guide bush and shank, nevertheless there are some various cases that these are the same in some characteristics such as material, type and dimensions. Effective parameters on proper material selection for the die common part are as follow [1]:

- price and preparing possibility
- Mechanical specification
- Thermal operation ability
- Production capacity

In designing die common parts, some specifications of members, dies and presses are used as the fundamental input data for their calculations. These information in each member are as follows:

### A. Bolster

A punch and matrix consist of two bolster which all parts of die set up on it. Required mechanical specifications for this part are high hardness and durability, moreover it must be absorb the vibration and easily machining. Thereby cast iron bolsters are more common than steel or aluminum bolsters[2]. However for manufacturing big pieces which need high rigidity and must be more strong under impact loads, mostly steel bolster are used in this cases. Required information for design and selection of bolster with considering type and dimensions of them are some parameters such as press table dimensions, die work area, shape of piece, press capacity and method of feeding plate into the die space.

### B. Guide pillar

Guide pillar is used to conduct the punch accurately while it gets through matrix thereby it sets up on the bolster however it must be symmetric about the major axes of die to be able to

F. A. Mohamadreza Mosalman Yazdi as a member of faculty of Maybod Islamic Azad University (corresponding author to provide phone: +989131516523; e-mail: mosalmanyazdi@yahoo.com).

S. B. Alireza Mosalman Yazdi as a member of faculty of Mehriz Islamic Azad University ( e-mail: hmosalm@gmail.com).

distribute the equal loads on the both side.

Wear resistance, easily machining, thermal operation ability and high module of elasticity are required mechanical specifications for guide pillars. Necessary information for design and selecting the type and dimension of pill are thickness of bolsters, weight of bolsters and the distance between punch and matrix in the case that the die be open so that called stroke[3-5].

### C. Guide bush

Guide bushes are used in order to lead the guide pillars on the dies and their material depends on the material of guide pillar and it must be made of such a material that is softer than the guide pillar[3]. These members must be strong enough in front of wear and has proper thermal operation ability. In designing these parts the die stroke, bolster thickness and the guide pillar diameter are important, the designing stages of them is shown in Fig. 1.

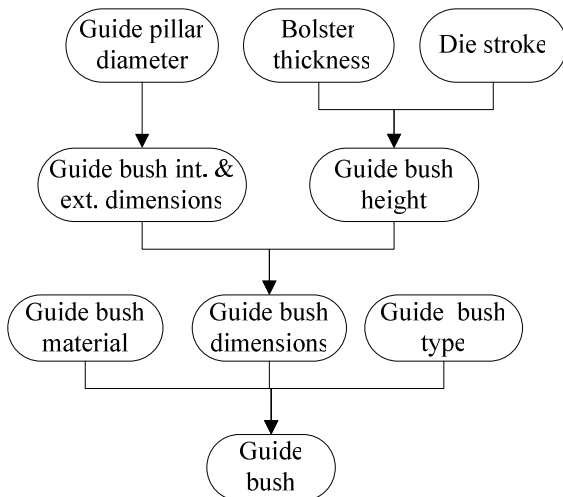

Fig. 1 A typical flowchart for designing guide bushes of common dies

### D. Shank

Shank is a pipe that is installed on the upper bolster and gets into the hole which is designed for it in the press. Shanks are available in two groups welded and screwed. Mechanical specifications which are required for determining the material of shanks are easy machining, wear resistance, high hardness, impact resistance and high toughness [5]. For designing the shanks of common dies a designer should follow some procedures which are depicted in Fig. 2.

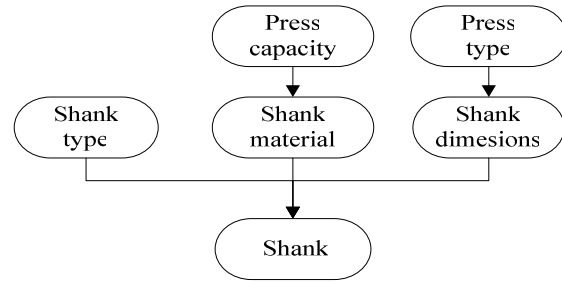

Fig. 2 A typical flowchart for designing shanks of common dies

## III. INTRODUCTION MECHANICAL DESKTOP SOFTWARE

Mech. Desk software has some unique abilities in designing of determined and no determined pieces, this software is equipped to the secondary program which has many abilities such as

- design and edit performance simultaneously
- build and analysis the area with high performance
- standard design ability of pieces such as screws, nuts, washers
- engineering calculations, modeling and stress analysis of pieces

Mech. Desk. software consists of AutoCAD and excel softwares that can draw elements in single part environment which is a parametric design environment and measuring them afterward determining the table of values which each parameter of the elements were drawn in the excel environment[6-7]. With selecting the table's row, measuring numbers get replaced with the parameters which are used for measuring consequently the element with the real scale that are observed.

This software has two design environments, single part environment and assembly environment thereby it is possible to draw a piece in the single part environment and use it in the assembly environment in a complex group of pieces to view it as an assembled shape.

with considering the abilities of Mech. Desk. software, various models of bolsters, guide pillars, guide bush, shanks, in the single part environment are drawn and are measured parametrically then their related special table is prepared.

Die designer give some primary data of each part for choosing them then the software with considering the data determine the type of all parts and draw their map and shows the assembled die.

## IV. PRACTICAL STUDY

With considering aforementioned subjects the Mech. Desk. software draw various models of bolsters, guide pillars, guide bushes, shanks in a single part environment as measuring them parametrically then the die designer enter the primary data of each part and after that software based on these data give the specifications of each part and the assembled view of them.

Example:

A mechanical part as shown in figure1 was pierced and blanked by progressive die. For selecting the details by software, the solely input data are the plate thickness and the press force that are 2.44mm and 200ton respectively. Afterward the software determines the die working area and top and bottom table dimensions of press. With consideration of figure1 and the style of feeding, bolster with four guide pillar are selected and the details are drawn by this software are shown in figures 4-7.

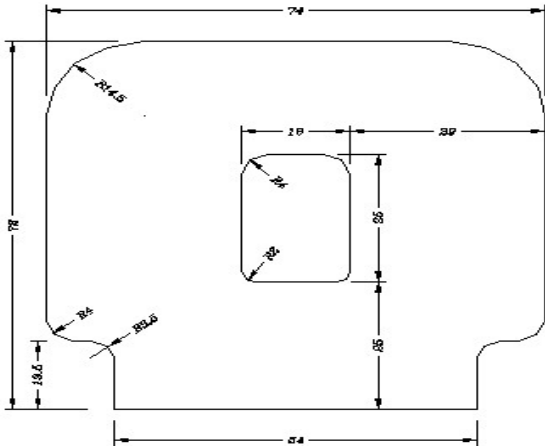
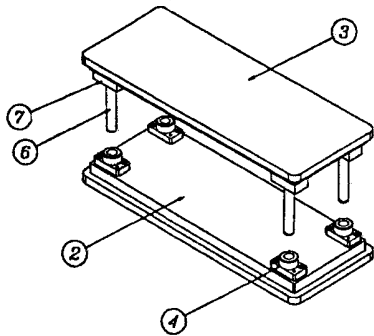

Fig. 3 The door cover scheme which connected to the middle post of Paykan car



a. Assembled die

b. Table of die specifications

ITEM	QTY	NAME	MATERIAL
1	1	REC.FOUR PILLAR	Cast iron
2	1	LOWER SHOE	Cast iron
3	1	UPPER SHOE	Cast iron
4	4	BUSH	Steel
5	4	GUIDE PILLARE	Steel
6	4	GUIDE	Steel
7	4	FLANGE	Steel

Fig. 4 Three dimensional view of die in the assembly environment

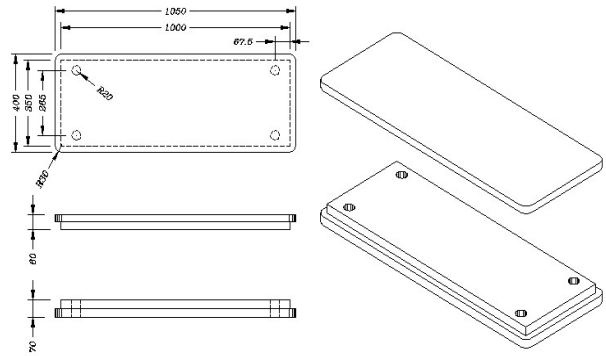

Fig. 5 Top and bottom bolster

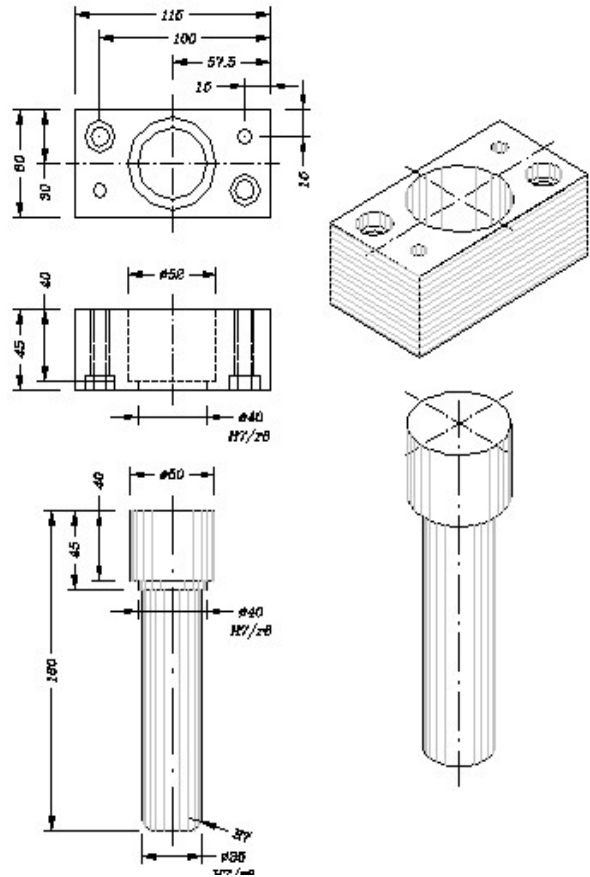

Fig. 6 Guide pillar drawing

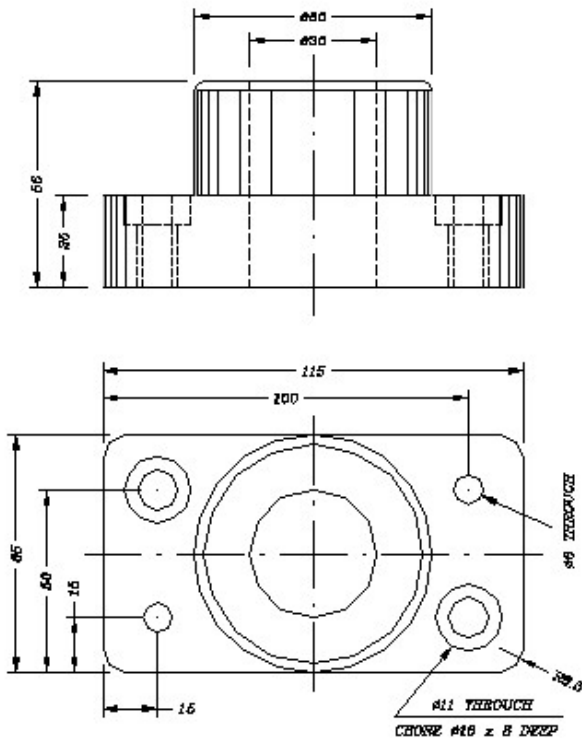

Fig. 7 Guide bush Drawing

#### V. CONCLUSIONS

Standardizing of common parts of punch and matrix metal die is so important in industry and moreover, using the Mech. Desk. software for this purpose has some benefits such as:

- 1-Minimize the designing time of mechanical pieces
- 2-The possibility of designing and drawing of pieces and three dimensional viewing them in as a single or as an assembled one in the complex is possible.
- 3-Using this method makes the same appearance for all the common parts of various dies.
- 4- Using this method standardize more the manufacturing cycle of common dies.

#### REFERENCES:

- [1] Metals HandBook (Forming), ASM, Vol. 14, 1988.
- [2] C.W. Wegst, Stahlshl Ussel, Verlag stahlschlüssel wegst GmbH, 1989.
- [3] C. Donaldson, G. H. Lecain and V.C. Goold, Tool Design, McGraw-Hill, 1943.
- [4] F. W. Wilson, P. D. Harvey and C. B. Gump, Die Design HandBook, McGraw-Hill, 1955.
- [5] J.R. Paquin, Die Design Fundamentals, Industrial Press INC., 1962.
- [6] D. wolff, Mechanical Desktop 6.0 Quick Reference, McGraw-Hill, 2000.
- [7] R. Cheng, Master Mechanical Desktop, Auto Desk Press, 1997.

**Mohamadreza Mosalman-Yazdi** was born in Yazd, Iran, in 1976. he received the B.S. degree in Manufacturing and Production Mechanical Engineering from Tabriz University , Iran, in 1998, the M.S. degree in Manufacturing and Production Mechanical Engineering from Sharif Industry University, Tehran, Iran, in 2000. He has been working as a member of faculty at Islamic Azad University of Maybod. His main research interests are in the area of robots designing.

**Alireza Mosalman-Yazdi** was born in Yazd, Iran, in 1976. He received the B.S. degree in Civil Engineering from Yazd University, Iran, in 1998, the M.S. degree in Structural Engineering from Kerman University, Kerman, Iran, in 2001. He has been working as a member of faculty at Islamic Azad University of Mehriz. His main research interests are in the area of Mechanic of structures.