

# Structure-vibration Analysis of a Power Transformer (154kV/60MVA/Single Phase)

Young-Dal Kim, Jae-Myung Shim, Woo-Yong Park, Sung-joong Kim, Dong Seok Hyun, and Dae-Dong Lee

**Abstract**—The most common cause of power transformer failures is mechanical defect brought about by excessive vibration, which is formed by the combination of multiples of a frequency of 120 Hz. In this paper, the types of mechanical exciting forces applied to the power transformer were classified, and the mechanical damage mechanism of the power transformer was identified using the vibration transfer route to the machine or structure. The general effects of 120 Hz-vibration on the enclosure, bushing, Buchholz relay, pressure release valve and tap changer of the transformer were also examined.

**Keywords**—Structure-Vibration, Transformer.

## I. INTRODUCTION

IN 1842, James Joule explained the magnetostrictive phenomena, which is a property of material that causes it to change its shape when subjected to a magnetic field [1].

A device having a mechanical exciting force is accompanied by resonance when external vibration frequency is equal to the natural frequency.

Changing the natural frequency by attaching a heavy object to change the mass or by connecting a differently shaped object such as a T-structure can serve as a measure for a specific vibration frequency [2].

An electric frequency of multiples of 120 Hz generated by the magnetostrictive phenomenon of the inner iron core is emitted through the transformer enclosure.

At this time, resonance can be increased by the frequency equal to the magnetostrictive phenomenon frequency of the transformer enclosure [3-4].

Forced damping of the enclosure or adjustment of its rigidity and mass can be performed to prevent resonance. Because the damping of a large structure such as a transformer enclosure is difficult in terms of cost and production efficiency, the adjustment of mass and rigidity can offer a solution.

Accordingly, natural frequency was obtained through modal analysis of the transformer enclosure while displacement was determined by analyzing the type of vibration.

The variation in measured natural frequency could form a basis for evaluating transformer noise and vibration.

Young-Dal Kim, Jae-Myung Shim, Woo-Yong Park and Sung-joong Kim are with Department of Electrical Engineering, Hanbat Nat'l University, Dukmyung-Dong Yuseong-Gu, Daejeon, 305-719, Korea.

Dong Seok Hyun, Dae-Dong Lee are with Department of Electrical Engineering, Hanyang University Haengdang-dong, Seongdong-gu, Seoul, 133-791, Korea.

## II. STRUCTURE-VIBRATION ANALYSIS OF THE POWER TRANSFORMER

### A. Initial Setting

The vibration generated from machine structures causes abnormal vibration, breakage of the machine and noise. A vibration analysis of the structure is important to prevent this vibration.

Modal analysis is applied to find the cause and solution of vibration and noise, which plays a role in the resonance. The vibration behavior of the structure surface is analyzed using the modal analysis tool and FFT analyzer for the vibration impulse.

Modal parameters including natural frequency, vibration mode and damping coefficient are measured.

Information on the vibration behavior of machines or parts during operation is obtained from ODS (Operating Deflection Shape). The behavior of a machine or a structure is observed and analyzed with vibration data measured using the signal analyzer, while sound intensity and sound power level of the noise data are likewise measured.

As shown in Fig. 1, the sound is felt with the same sound pressure as that of the pure tone within the frequency range of 120-10 kHz, and this frequency range can be set as the modal analysis range. 120 Hz is the first mode, which is not negligible. Therefore, the modal analysis is performed within the frequency range of 120-10 kHz.

The B&K pulse system was used for obtaining and analyzing vibration data, and the ANSYS was used as the analysis tool.

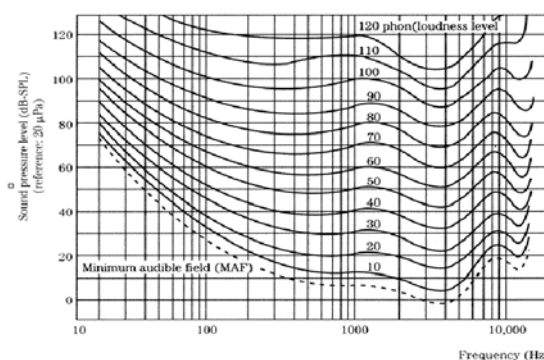

Fig. 1 Loudness curve

### B. FEM of ANSYS

Prism/Tetrahedral element was not used in the

ANSYS/SOLID187 in this study. The boundary condition of Young's modulus was 200 Gaps (for cast carbon steel); the density was  $7,800\text{kg/m}^3$ ; and the Poisson's ratio was 0.32. The node size to use the block Lantz's method was set at 173,249 and the element size at 87,016 [3].

The ANSYS was used as an analysis tool, using rectangular elements that form meshes. The free mesh is useful in making meshes with irregular forms for a complex shape such as a transformer enclosure.

In addition, the number of meshes for the whole model was set by adding smart size meshes. Thus, a mesh shape in Fig. 3 was obtained.

In Fig. 2, the part that comes into contact with the ground under the weight of the transformer has nearly no displacement by vibration, and a constraint condition of complete fixation was applied. The effect of insulation oil was excluded.

The natural frequency range was set at 0-300 Hz for the block Lantz's method, and the number of mode extraction was set at 60. The minimum natural frequency was about 30 Hz, and multiple natural frequencies were found. Natural frequency analysis was performed under the initial stress.

The whole vibration was analyzed as a combined value of individual modes as shown in Table I.

TABLE I  
RESULTS OF THE FEM ANALYSIS

No.	Natural frequency (Hz)	No.	Natural frequency (Hz)	No.	Natural frequency (Hz)
1	28.6	21	142.8	41	210.3
2	36.7	22	143.6	42	212.6
3	45.5	23	149.8	43	216.5
4	56.6	24	152.5	44	223.5
5	63.6	25	155.7	45	225
6	70.2	26	160.9	46	227
7	88.8	27	162	47	229.6
8	97.6	28	167.9	48	234.6
9	99.3	29	170.5	49	235.1
10	99.9	30	173.8	50	237.8
11	101.8	31	179.5	51	238.2
12	109.5	32	182.1	52	241.1
13	115.7	33	186.6	53	247.6
14	117.1	34	189.5	54	248.3
15	118.1	35	192.1	55	252.2
16	121.3	36	196.8	56	254.6
17	130.5	37	199.3	57	255.1
18	131.7	38	201.1	58	255.8
19	136.1	39	202.4	59	259.3
20	140	40	205.2	60	260

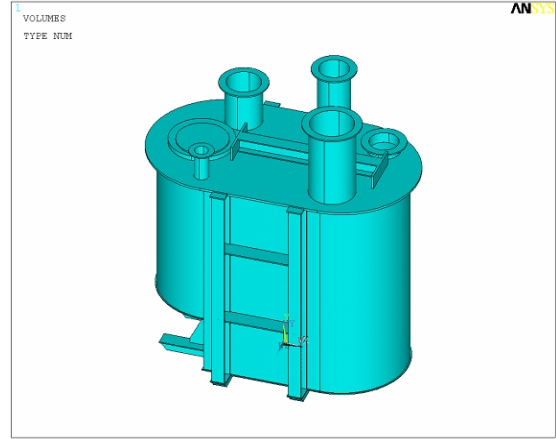

Fig. 2 Finite element model

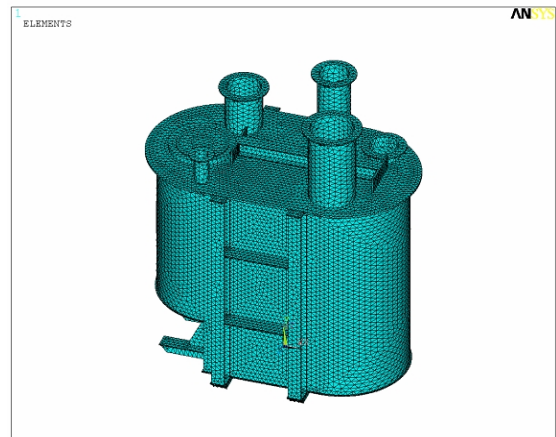

Fig. 3 Mesh shape

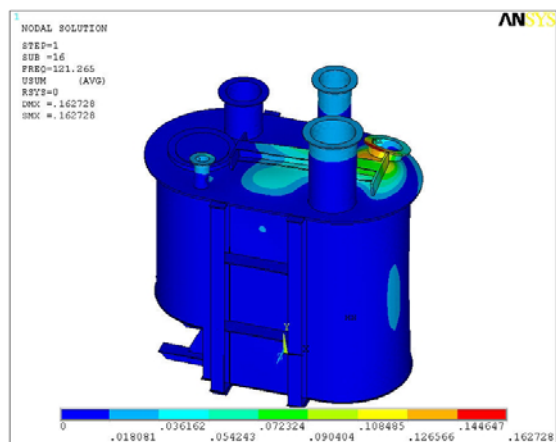

Fig. 4 16<sup>th</sup> resonance (121.3 Hz)

Fig. 4 shows the result of the analysis at 120 Hz, exhibiting partial resonance, which had no effect on the transformer.

Fig. 5, however, shows possible vibration in the busing, even though there was no significant effect on the transformer.

Fig. 6 shows the result of the natural modal analysis at 240 Hz, exhibiting partial resonance, which had no effect on the transformer.

In Fig. 7, however, the resonance occurs at the upper part of the transformer, and large vibration is possible in the bushings.

Results of the natural modal analysis showed that natural frequency existed at around 120 Hz and 240 Hz, and that vibration was possible.

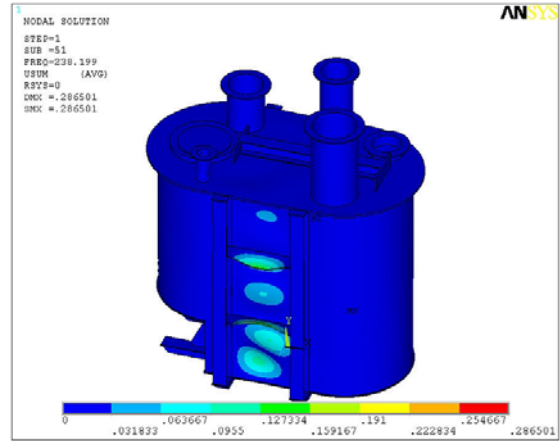

Fig. 7 51<sup>st</sup> resonance (238.2 Hz)

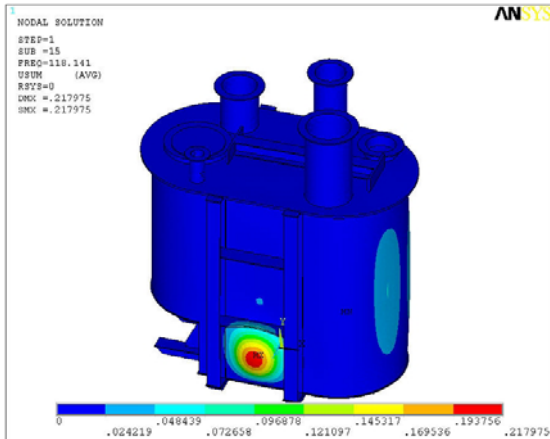

Fig. 5 15<sup>th</sup> resonance (118.1 Hz)

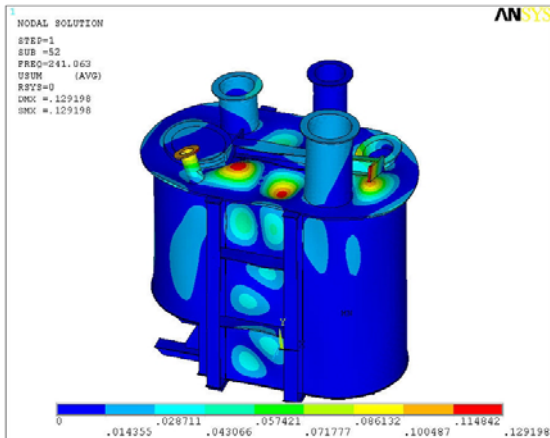

Fig. 6 52<sup>nd</sup> resonance (241.1 Hz)

### C. Vibration of the Transformer

B&K 4384 accelerometer, B&K Nexus charge type amplifier and B&K pulse system were used in the data acquisition/analysis.

Fig. 8 shows the system used to find the vibration speed (mm/sec) at each measurement position of the transformer in operation.

The extent of the modal analysis is determined by the operating condition, and the audio frequency range of the transformer is 20 Hz-15000 Hz. In particular, the physical strength of the sound is determined by the sound pressure, but the strength felt by a human being varies also based on the sound frequency. Measured frequency range was set at 20-2 kHz (Step = 1 Hz).

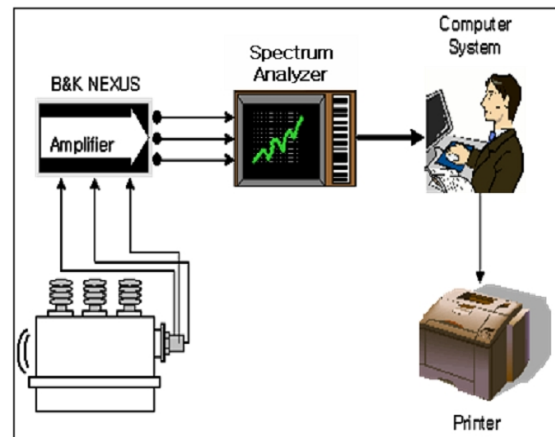
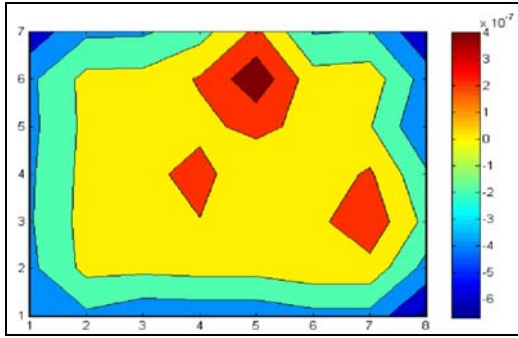
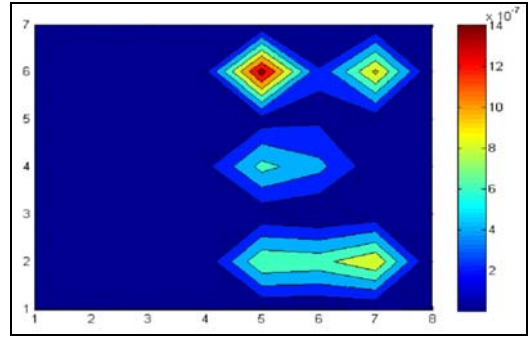

Fig. 8 Composition of the vibration measurement system



[1] 120 Hz



(a) 120 Hz

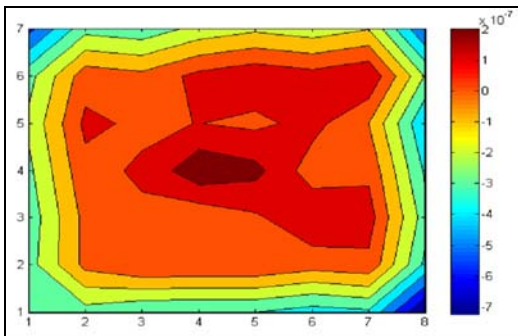

[2] 240 Hz

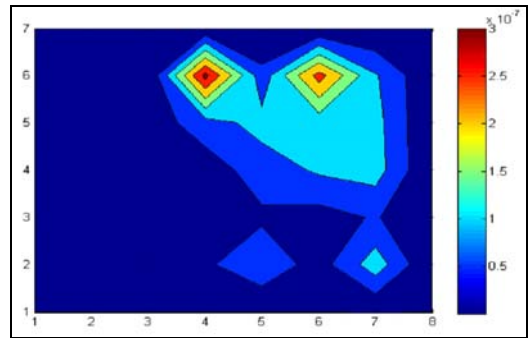

(b) 240 Hz

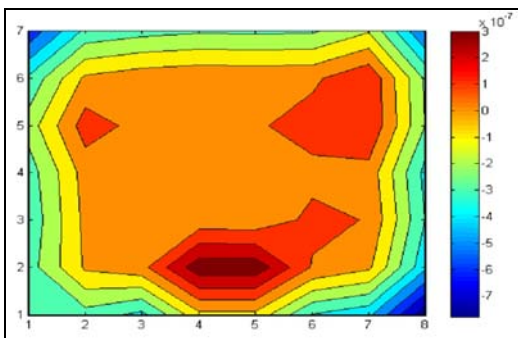

[3] 360 Hz

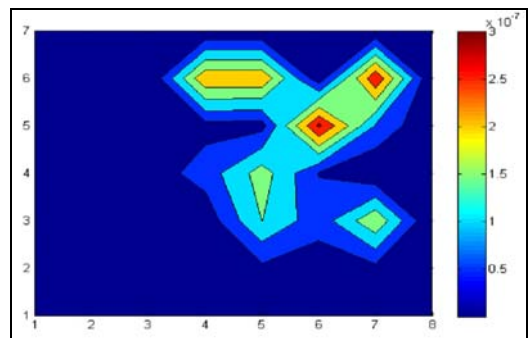

(c) 360 Hz

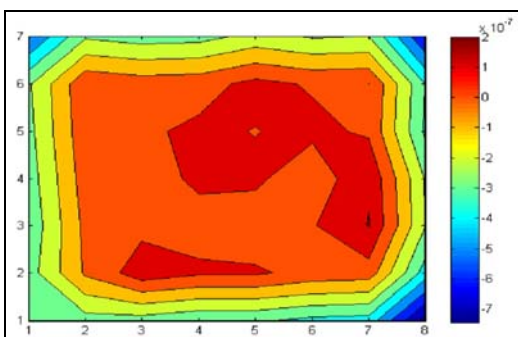

[4] 480 Hz

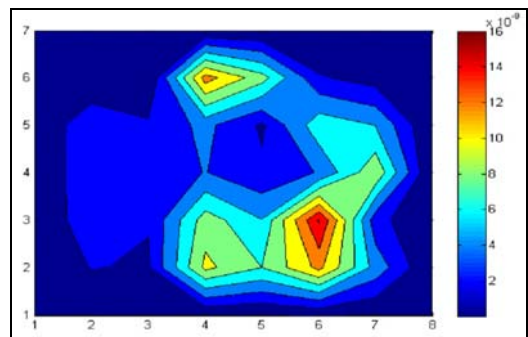

(d) 480 Hz

Fig. 9 Substation A

Fig. 10 Substation B

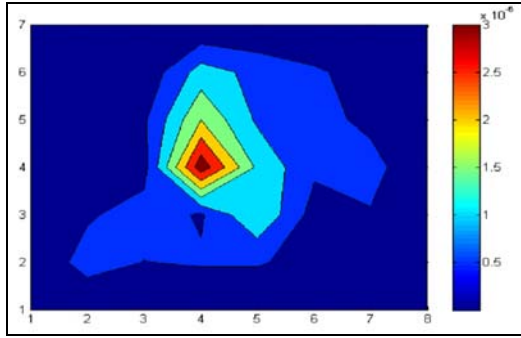

(a) 120 Hz

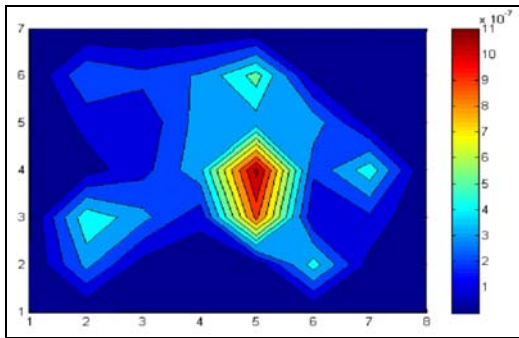

(b) 240 Hz

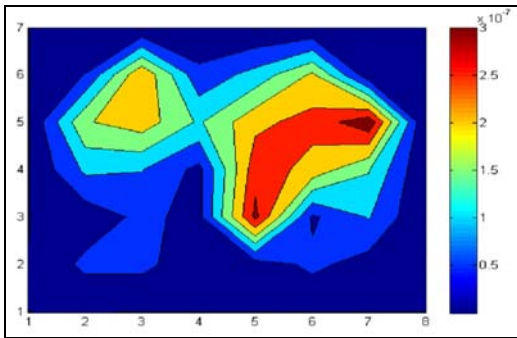

(c) 360 Hz

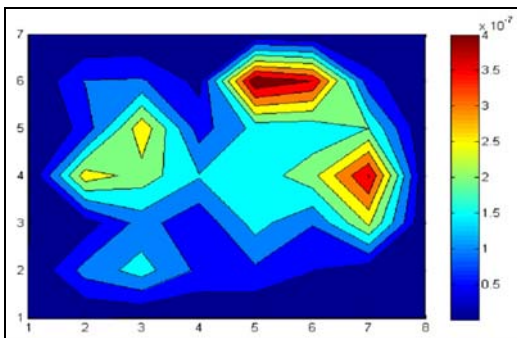

(d) 480 Hz

Fig. 11 Substation C

vibration with 120 Hz component was the highest in general. Large vibrations occurred at 360 Hz and 420 Hz for some transformers, indicating that diverse types of vibration occurred on the enclosure surface of each transformer.

### III. CONCLUSION

The structure-vibration analysis of a single-phase power transformer was performed. Vibration of the enclosure, bushing, Buchholz relay, pressure release valve and tap changer was likewise analyzed using the mobility measurement.

Mobility response and coherence to the test reliability were verified. Possible resonance of the enclosure was observed at a frequency of about 120 Hz, which is considered to be brought about by damping of the structure.

There was no resonance at a frequency of about 120 Hz for the bushing, Buchholz relay and pressure release valve, attributed to the resonance-resistant design.

In designing the transformer enclosure, the magnitude, phase and coherence must be considered with regard to the effect of structural vibration.

### REFERENCES

- [1] Mou, Gang. Modeling and Control of a Magnetostrictive System for High-precision Actuation at a Particular Frequency. 2002. pp. 4-5.
- [2] Dukkipati, Rao V. Advanced Mechanical Vibration.
- [3] David Jiles, "Introduction to magnetism and magnetic materials", Chapman and Hall, pp. 89-106, 1991.
- [4] M.J. Dapino, R.C. Smith, A.B. Flatau "An active and structural strain model for magnetostrictive transducers", SPIE symposium on Smart Structures and Materials, 1998, Paper#3329-24.

Measurements were performed in substations A, B and C. The maximum vibration was 0.01mm/s~3.36mm/s, and the