

# Design and Fabrication of a Miniature Railway Vehicle

Max Ti-Kuang Hou, Hui-Mei Shen, Chiang-Ni Lu, and I-Jen Hsu

**Abstract**—We present design, fabrication, and characterization of a small (12 mm × 12 mm × 8 mm) movable railway vehicle for sensor carrying. The miniature railway vehicle (MRV) was mainly composed of a vibrational structure and three legs. A railway was designed and fabricated to power and guide the MRV. It also transmits the sensed data from the MRV to the signal processing unit. The MRV with legs on the railway was moving due to its high-frequency vibration. A model was derived to describe the motion. Besides, FEM simulations were performed to design the legs. Then, the MRV and the railway were fabricated by precision machining. Finally, an infrared sensor was carried and tested. The result shows that the MRV without loading was moving along the railway and its maximum speed was 12.2 mm/s. Moreover, the testing signal was sensed by the MRV.

**Keywords**—Locomotion, Micro-Robot, Miniature Railway Vehicle, Stick-Slip.

## I. INTRODUCTION

THE sensor-carrying robots are usually designed to sense signals in environments that people are hard or impossible to reach. In different applications, the sensor-carrying robots require different vehicles to carry sensors. For example, in pipelines, several available vehicles with different locomotive mechanisms were developed to provide mobility to in-pipe robots [1]-[4]. When the robots travel on uneven, slippery and flexible environment, the vehicle might be designed as an earthworm [5]. Under water, lots of efforts have been made in developing underwater vehicles to overcome challenging engineering problems caused by the underwater environment [6]. To extend the range of applications, e.g. to collect environmental information from a small close space, the size reduction of the sensor-carrying robots is an important issue. To reduce their size, the vehicle size also has to be reduced.

The small existing micro vehicles have dimensions on the order of tens of micrometers [7], hundreds of micrometers [8], millimeters [9] or centimeters [10]. The vehicles with dimensions on the order of tens or hundreds of micrometers usually require peripherals to be powered, steered, monitored

and controlled. Hence, the sensor-carrying is hard to achieve and unnecessary. Besides, the moving area of these micro vehicles is also limited by the peripherals. Rather than sensor-carrying vehicles, they are more suitable to be used for micro-assembly. The vehicles with dimensions on the order of centimeters are convenient to carry sensors. However, their size limits their applications to larger spaces where they can access. For example, it is not easy to make such vehicles patrol in a notebook computer. Carrying a sensor to move in a small close space, such as in the inner space of a precision instrument, the vehicles with dimensions on the order of millimeters are most appropriate.

To reduce the vehicle size down to between a cubic centimeter and a cubic millimeter, several modules (energy, communication, onboard electronic, sensor and actuator) should be considered simultaneously. It is complicated to do so. For simplicity, a new remote sensing method through railways was proposed. Only sensor was carried by the micro vehicle. Other modules were unloaded and were integrated with the sensor-carrying vehicle through the railway. The railway takes charge of the transmission of sensed data and electric power.

Based on this new concept, the micro railway vehicle should be designed to receive the electric power and send the sensed data efficiently. Between the vehicle and the railway, rolling and sliding contacts are adequate to fulfill the foregoing requirement. Rolling contact, which is typically achieved by wheels, electromagnetic motors and power transmission mechanisms, makes the vehicle size easily exceeding a cubic centimeter. Sliding contact achieved by inertial drives, walking mechanisms, inch-worm or actuators with asymmetrical friction forces [11] is more promising for the micro vehicle to fit the size requirement. Among these sliding mechanisms, inertial drives (stick-slip) are used as a study case [12].

## II. PRINCIPLE AND DESIGN

### A. Stick-Slip

Stick-slip means the phenomenon of a sudden pulling motion that happens when an object is sliding over another. The phenomenon is generated by the continuous switching between these objects sticking to and sliding over each other. This switching corresponds to various friction forces between the contacting surfaces. Normally, the kinetic friction force between two surfaces is smaller than the static friction force. If an applied force suddenly overcomes the static friction force, the friction force suddenly becomes the kinetic friction and

This work was supported in part by the Taiwan National Science Council under Grant NSC 97- 2627- B- 239- 001 and NSC 97-2511-S-239 -002.

M. T.-K. Hou, H.-M. Shen, and J. Liu are with the Department of Mechanical Engineering, National United University, 1, Lienda, Miaoli, 36003 Taiwan (corresponding author: M. T.-K. Hou, phone: +886-37-381329; fax: +886-37-381333; e-mail: max@nuu.edu.tw).

I.-J. Hsu is with the Department of Physics, Chung Yuan Christian University, 200, Chung Pei Rd., Chung Li, 32023 Taiwan (e-mail: ijhsu@cycu.edu.tw).

cause a sudden increase in the relative velocity between the two objects.

**B. Design**

The miniature railway vehicle (MRV) mainly contains the vibrational structure, the forelegs, and the hind leg, as shown in Fig. 1. The vibrational structure, made of a bilayer of piezoceramic and brass, can be excited to vibrate due to the bimorph effect. The folded legs, made of brass, were designed to experience the vibration and continuously push the vehicle forward. Besides, they contact the railway for electrical connection. The railway contained three copper strips and short guiding walls, as shown in Fig. 2. When the vehicle is on the railway, each leg contacts the different copper strip. Hypothetically, applying the sinusoidal voltage on the middle strip and grounding the outside strips, the vibrational structure vibrates. Then, the legs vibrate and the vehicle moves forward.

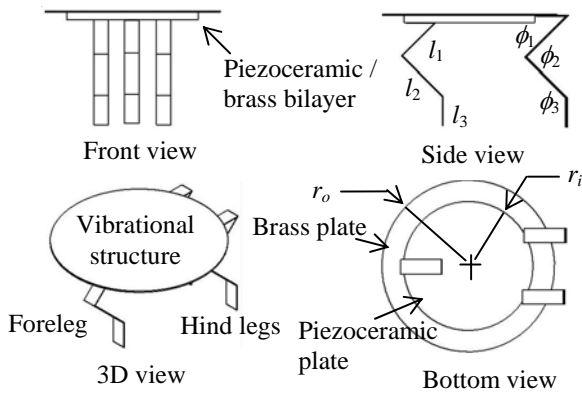

Fig. 1 Design of the MRV

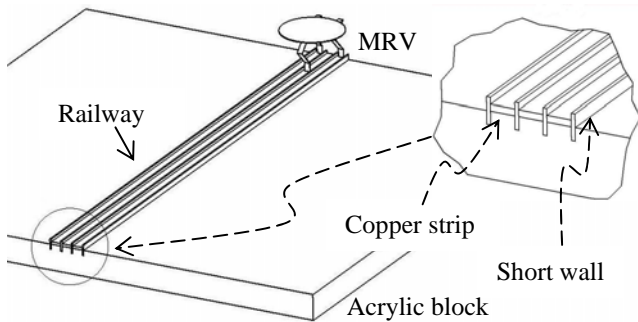

Fig. 2 Design of the railway

**C. Operation Stage**

Two operation stages, sticking- and slipping-stages, are determined. The vibrational structure with mass of  $m$  is supported and led by three deformable legs, as shown in Fig. 3. In the sticking-stage, the inertia mass  $m$  moves downwards and the friction force increases. The static friction force is large enough to keep the MRV sticks to the railway at a certain point. Subsequently, the inertia mass bounces backwards and the

friction force decreases in the slipping-stage. At the same time, the MRV slides along the railway because the restoring of the legs provides a kinetic energy forward. Alternating these two stages makes the MRV move forward.

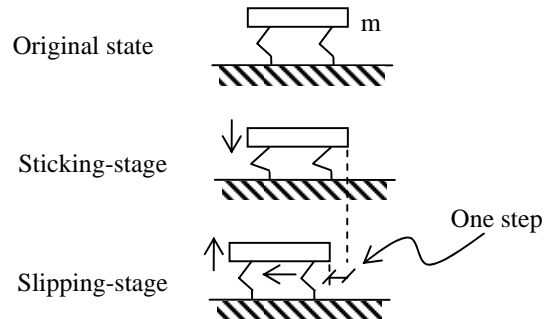

Fig. 3 Operation of the MRV

**D. Modeling**

For simplicity, the MRV was modeled as a vibrating mass  $m$  supported by one leg and confined between two brackets without mass, as shown in Fig. 4. The leg was simplified into tilted linear spring with the spring constant of  $k_L$ . The tilt angle between the rail and the leg is  $\theta$ . Only the contacting surface between the rail and the leg experienced the friction force.

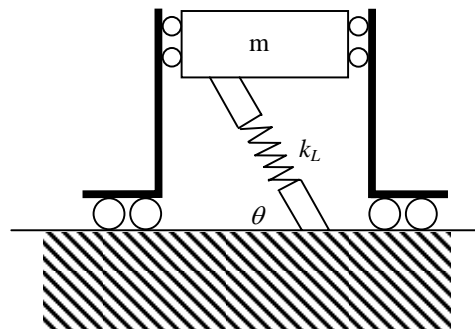

Fig. 4 Modeling of the MRV

TABLE I  
PARAMETERS USED IN THE SIMULATION

Parameter	Value	Unit
$l_1$	5	mm
$l_2$	5	mm
$l_3$	2	mm
$r_o$	12	mm
$r_i$	9	mm
$\phi_1$	57	degree
$\phi_2$	107	degree
$\phi_3$	87	degree
Thickness of brass plate	70	$\mu\text{m}$
Thickness of piezoceramic plate	120	$\mu\text{m}$
Thickness of leg	100	$\mu\text{m}$

**E. Simulation**

The leg was simulated by using COMSOL Multiphysics to numerically predict the stiffness of the spring, as shown in Fig.

5. The parameters used in simulation were shown in Table I. Then, the values of the parameters shown in Fig. 4 were determined as  $k_L = 336.2 \text{ N/m}$  and  $\theta = 74^\circ$ .

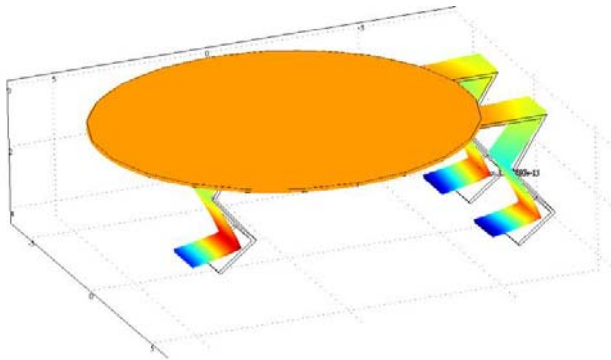

Fig. 5 The FEM model of the MRV.

### III. FABRICATION AND EXPERIMENT

#### A. Fabrication

The MRV was fabricated using a precision machining process. First, a commercial piezoceramic element with resonant frequency of 9.2 kHz was used as the vibrational structure. Second, the 2D pattern of the leg was defined by CNC machining. Then, the 3D shape of the leg was formed by precision bending. Finally, the MRV was assembled by welding under the assist of an assembly jig, as shown in Fig. 6(a). Fig. 6(b) shows the manufactured vehicle.

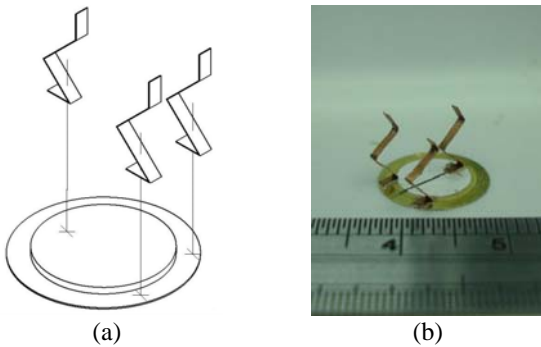

Fig. 6 (a) Assembly and (b) the prototype of the MRV

The railway was also fabricated using a precision machining process. First, three copper strips were cut by CNC machining. Second, an acrylic block was used as the base, as shown in Fig. 2. Four slots were cut on the block surface by laser machining. Then, four short walls made of PMMA were inserted into the slots for guiding and isolating the individual legs of the MRV. Finally, the copper strips were respectively adhered between each pair of short walls. Fig. 7 shows the manufactured railway with electrical connections.

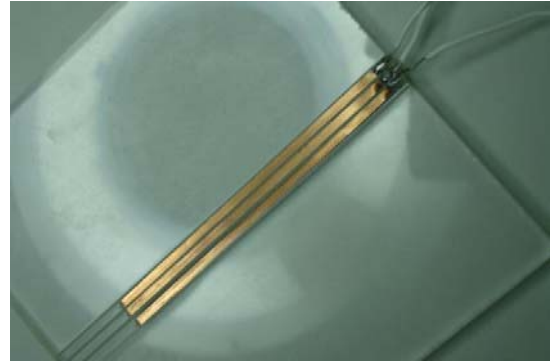

Fig. 7 The manufactured railway

#### B. Experiment

To characterize the dynamic behavior, the MRV was put on the railway with each leg contacting different strip. The sinusoidal voltages with different frequencies were applied to the middle strip. The outside two strips were grounded. Then, the speed was measured using a CCD camera. The motion of the MRV is shown in Fig. 8.

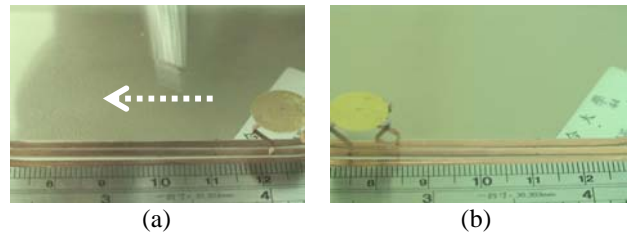

Fig. 8 The snapshots of the captured video<sup>1</sup> showing the continuously vibration-induced motion of the MRV at (a) time = 0 second, and (b) time = 2 second

The described experiment was repeated to test the dynamic behavior of the MRV with loading. The loadings attached on the upper surface of the MRV were made of paper pieces. Each piece of paper was 160 mg in mass. Up to 1.28 g was tested and measured.

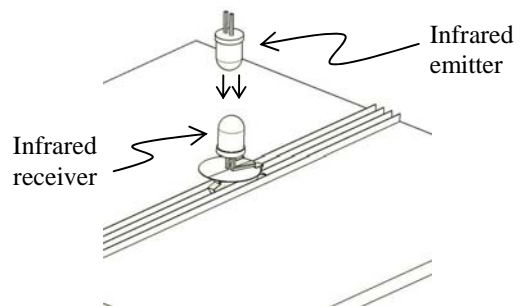

Fig. 9 Experiment setup for testing the sensing ability of the MRV

The sensing ability was determined by utilizing a pair of infrared emitter and receiver, as shown in Fig. 9. The infrared

<sup>1</sup> The video can be found at <http://tw.youtube.com/watch?v=XLItGVFOz8>

receiver was mounted on the top surface of the MRV. The infrared emitter was placed above the railway. If the receiver is brought by the MRV to the position under the emitter, and the infrared light is detected by the receiver, then the sensing ability can be proved.

#### IV. RESULTS AND DISCUSSIONS

##### A. Dynamic Behavior of MRV without Loading

The maximum speed of the MRV without loading was measured as 12.2 mm/s in the driving frequency of 200 kHz, as shown in Fig. 10. It was not obtained at the resonant frequency of the piezoceramic element (i.e. 9.2 kHz). This might be partially due to the resonant frequency of the MRV is not equal to 9.2 kHz and partially due to the higher driving frequency leads to much more moving steps in one second. However, the speed decreases as the driving frequency exceeds 200 kHz. This implies the very small vibrational amplitude results in the distance of each step drops quickly.

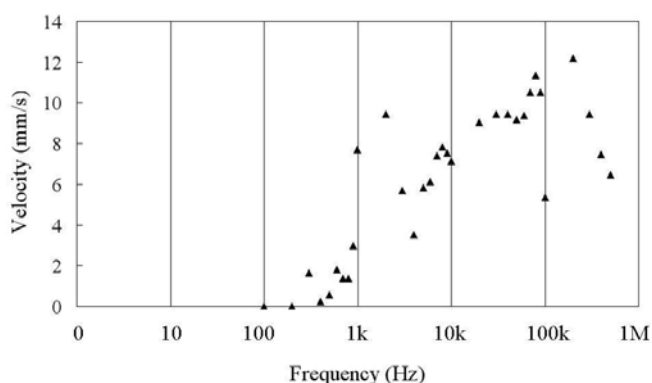

Fig. 10 Characterization of the MRV: the velocity versus the driving frequency

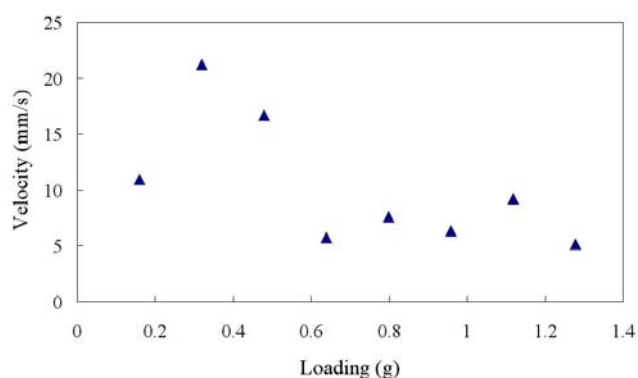

Fig. 11 Characterization of the MRV: the velocity versus the loading

##### B. Dynamic Behavior of MRV with Loading

The MRV with different loading were tested in the driving frequency of 200 kHz. As shown in Fig. 11, the result shows the MRV can carry 1.28 g of mass. It demonstrates the MRV can be used for sensor carrying with mass less than 1.28 g.

##### C. Sensing Ability

Fig. 12 shows the sensing ability of the MRV. The readout voltage was zero volts as the infrared emitter was located above the infrared receiver mounted on the MRV. The readout voltage was about 2.7 volts as the emitter was removed.

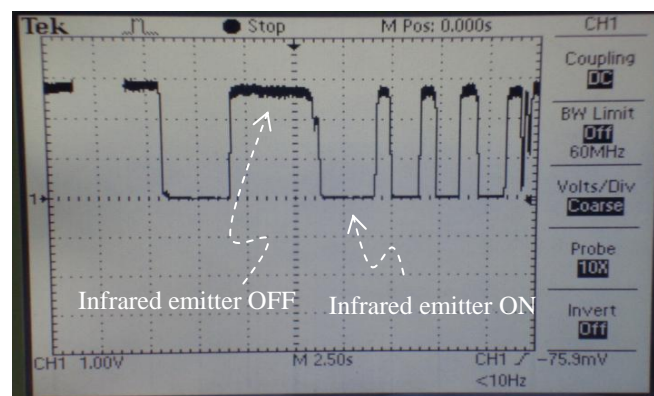

Fig. 12 Sensing ability of the MRV

#### V. CONCLUSION

In this paper, the MRV for sensor carrying was designed, fabricated, and characterized. The railway was designed to transmit driving and sensed signals for eliminating bulky modules for power and communication. The stick-slip mechanism was adopted to move the MRV. Based on analysis and design, the MRV and the railway were fabricated and tested. The maximum speed of the MRV without loading is 12.2 mm/s. The MRV can carry 1.28 g of mass. The MRV can be used for sensor carrying and can transport the sensors to wherever the railway was laid.

#### ACKNOWLEDGMENT

Professor Chyn-Shu Deng and Professor Su-Tang Chiou at the National United University are appreciated for their assistance to the fabrication of the MRV devices proposed.

#### REFERENCES

- [1] J. Okamoto, Jr., J. C. Adamowski, M. S. G. Tsuzuki, F. Buiuchi, and C. S. Camerini, "Autonomous system for oil pipelines inspection," *Mechatronics*, vol. 9, pp. 731–743, 1999.
- [2] K. Suzumori, T. Miyagawa, M. Kimura, and Y. Hasegawa, "Micro inspection robot for 1-in pipes," *IEEE/ASME Trans. Mechatronics*, vol. 4, pp. 286–292, Sep. 1999.
- [3] H. T. Roman, B. A. Pellegrino, and W. R. Sigrist, "Pipe crawling inspection robots: An overview," *IEEE Trans. Energy Convers.*, vol. 8, pp. 576–583, Sep. 1993.
- [4] W. Neubauer, "A spider-like robot that climbs vertically in ducts or pipes," in *Proc. IEEE/RSJ Int. Conf. Intelligent Robots, Systems*, pp. 1178–1185, 1994.
- [5] Y. P. Lee, B. Kim, M. G. Lee, and J.-O Park, "Locomotive Mechanism Design and Fabrication of Biomimetic Micro Robot Using Shape Memory Alloy," in *Proceedings of the 2004 IEEE International Conference on Robotics & Automation*, pp. 5007–5012, Apr. 2004.
- [6] J. Yuh, "Design and Control of Autonomous Underwater Robots: A Survey," *Autonomous Robots*, vol. 8, pp. 7–24, 2000.

- [7] B. R. Donald, C. G. Levey, C. D. McGray, I. Paprotny, and D. Rus, "An Untethered, Electrostatic, Globally Controllable MEMS Micro-Robot," *Journal of Microelectromechanical Systems*, vol. 15, pp. 1–15, Feb. 2006.
- [8] K. Vollmers, D. R. Frutiger, B. E. Kratochvil, and B. J. Nelson, "Wireless resonant magnetic microactuator for untethered mobile microrobots," *Applied Physics Letters*, vol. 92, pp. 144103-1-3, 2008.
- [9] U. Simu, and S. Johansson, "Analysis of quasi-static and dynamic motion mechanisms for piezoelectric miniature robots," *Sensors and Actuators: A*, vol. 132, pp. 632–642, 2006.
- [10] Q. Chang-jun, M. Pei-sun, and Y. Qin, "A prototype micro-wheeled-robot using SMA actuator," *Sensors and Actuators: A*, vol. 113, pp. 94–99, 2004.
- [11] J.-M. Breguet, S. Johansson, W. Driesen, and U. Simu, "A review on actuation principles for few cubic millimeter sized mobile micro-robots", in *10th International Conference on New Actuators (Actuator 2006)*, pp. 374-381, 2006.
- [12] J.-M. Breguet, and R. Clavel, "Stick and Slip Actuators: design, control, performances and applications," in *1998 International Symposium on Micromechatronics and Human Science*, pp. 89-95, 1998.