

Generator Capability Curve Constraint for PSO Based Optimal Power Flow

Mat Syai'in, Adi Soeprijanto, and Takashi Hiyama

Abstract—An optimal power flow (OPF) based on particle swarm optimization (PSO) was developed with more realistic generator security constraint using the capability curve instead of only P_{\min}/P_{\max} and Q_{\min}/Q_{\max} . Neural network (NN) was used in designing digital capability curve and the security check algorithm. The algorithm is very simple and flexible especially for representing non linear generation operation limit near steady state stability limit and under excitation operation area. In effort to avoid local optimal power flow solution, the particle swarm optimization was implemented with enough widespread initial population. The objective function used in the optimization process is electric production cost which is dominated by fuel cost. The proposed method was implemented at Java Bali 500 kV power systems contain of 7 generators and 20 buses. The simulation result shows that the combination of generator power output resulted from the proposed method was more economic compared with the result using conventional constraint but operated at more marginal operating point.

Keywords—Optimal Power Flow, Generator Capability Curve, Particle Swarm Optimization, Neural Network

I. INTRODUCTION

THE recent development of optimal power flow method has adopted the artificial intelligence (AI) algorithm in gaining optimal solution of generator scheduling. The most popular intelligence optimization technique already applied were genetic algorithm, fuzzy, simulated annealing, expert system, neural network, PSO and the hybrid of them [1-12]. Among of these, PSO is the one received greatest attention caused by its capability in avoiding local optimal solutions. Most PSO papers stress on developing new techniques in effort to achieve optimal solution considering non linear power system characteristic [5-7]. Only view papers give attention in developing proper or more realistic constraint to the optimal power flow problem. As an example, more tight constraints such as Sudhakaran et.al, Pablo et.al and Gaing et.al [1-3] were used in solving economic dispatch problem. As a consequence, such tight constraint will result a pessimistic solution. Actually the optimum value of the

objective function –in this case system operation cost –can still be reduced if we can alleviate the constraint especially generator security constraint. So far researchers used P_{\min}/P_{\max} and Q_{\min}/Q_{\max} to limit the generator output inside the secure operating condition. Matlab in its Power System Simulation Package used more realistic generator security constraint that is the generator capability curve which is approximated with five straight lines [4]. Although it is already better than P_{\min}/P_{\max} and Q_{\min}/Q_{\max} but the generator still can't operate in the marginal area in order to get lower operation cost.

This research is aimed to develop neural network based generator capability curve and the security check algorithm that will be used as enhanced constraint of optimal power flow. The algorithm is very simple and flexible especially for representing non linear generation operation limit near steady state stability limit and under excitation operation area. Another constraint such as bus voltage limitation, equality and inequality of power is remains the same. The OPF solution is solved by PSO which already become a well established optimization method for generator dispatch. The inherent characteristic of PSO that is the capability to avoid local optimum point is pronounced by an enough widespread initial population. It is hoped that with the proposed additional constraint, generators can operate at their marginal operating point so that the most economic operation condition can be achieved. The simulation is conducted at 500 kV Java-Bali Power System. The simulation result will be compared with OPF solution using conventional (P_{\min}/P_{\max} and Q_{\min}/Q_{\max}) constraint.

II. METHODOLOGY

A. Developing NN Model for Generator Capability Curve

In order to make generator capability curve possible as OPF constraint, a constructive back propagation NN Model for generator capability curve should be designed first. The algorithm is as follows:

1. Prepare a Neural Network with one input and one target. The number of hidden layer will be constructed automatically by constructive backpropagation (look at Fig. 1)
2. Use the angle θ and the related distance between origin and curve line R as the input and target respectively (look at Fig. 2).
3. Sample a set of input-target data along the curve line and train the NN using the data set. The accuracy of the model resulted is depend on the number of input-target data used.

Mat Syai'in is a lecturer and graduate student at the electrical engineering, Institut Teknologi Sepuluh Nopember, Surabaya, East Java, Indonesia 60111. (phone: 62-31-5911285; fax: 62-31-5911285; e-mail: syai_in@elect-eng.its.ac.id).

Adi Soeprijanto is a lecturer at the electrical engineering, Institut Teknologi Sepuluh Nopember, Surabaya, East Java, Indonesia 60111. (phone: 62-31-5911285; fax: 62-31-5911285; e-mail: adisup@elect-eng.its.ac.id).

T. Hiyama is with the Department of Electrical and Computer Engineering, Kumamoto University, Kumamoto 860-8555, Japan (e-mail: hiyama@eecs.kumamoto-u.ac.jp).

4. Test the resulting NN model with data other than already used at step 3. Compare the NN output with the related real distance between the origin and the curve line.
5. By entering the angle θ from $0^\circ - 180^\circ$ to the NN model and plotting the resulting input-output value, generate the whole curve. Compare the result with the original capability curve.

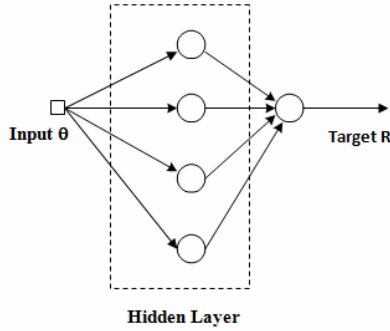

Fig. 1 NN Model for Generator Capability Curve

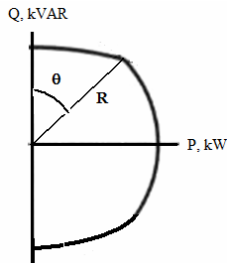

Fig. 2 Data Pair for NN Learning: θ and R

Note that great error usually happened at edge points caused by discontinuity of the curve. A simple technique to overcome this problem is by including the edge points as data in the learning process. Frequently, the under excitation operation limit (area under P axis) are more non linear than what is shown at Fig. 2. As will be shown the extremely useful characteristic of the proposed algorithm is its high flexibility to overcome the non linearity.

B. Developing Security Check Algorithm

The generator scheduling solution by proposed OPF should guarantee secure operation for all generators. A security check algorithm was developed as follows:

1. From the data of each generator power output (P and Q) resulted by PSO, the related angle θ and magnitude R was computed.
2. By entering the angle data θ as an input of the NN Model resulted before, one can get a reference distance (R_{ref}) from the output.
3. The generator security was checked by comparing the value of R and R_{ref} . If $R \leq R_{ref}$ the generator is secure but if $R > R_{ref}$ the generator is unsecure.

Fig. 3 gives a visual relationship between generator operating point (P,Q), θ , R and R_{ref} . Fig. 4 shows the security check algorithm.

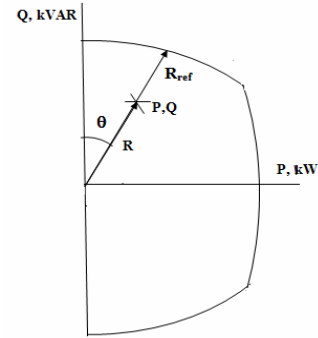

Fig. 3 Relationship between P,Q, θ , R and R_{ref}

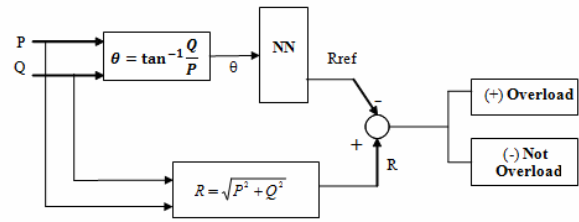

Fig. 4 The security check algorithm

C. Overall Simulation Flowchart

Fig. 5 shows the overall simulation flowchart of PSO based OPF. As input data were network impedances and loads while the generator power will either be created randomly or regulated as initial population. A regulated widespread initial population is preferable to avoid local optimum solution.

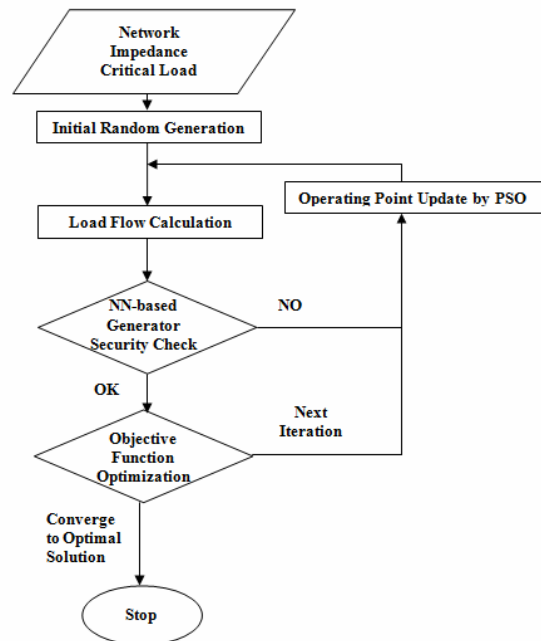

Fig. 5 PSO based OPF Flowchart

Load flow calculation was conducted to compute the total losses and power generation of swing generator. Then each generator power output will be checked using NN based security check algorithm developed before for generator safety. If there is one or more unsecure generators, PSO

algorithm will update power generator combination except the swing generator and repeat the process until all generators are secure. The other constraint such as system voltage level, equality and inequality of power were also processed at this step.

The optimal solution was founded by comparing the value of objective function of all possible generation combination via many iterations. The operation cost which is dominated by fuel cost was used as the objective function. At each iteration, the value of objective function of new individu should be compared with the old one and the lower operating condition cost was used as local best condition for the next iteration. Individu having the lowest cost among community should be used as global best condition for the next iteration. The PSO algorithm to update the generators operating point [1]:

$$X_i^{k+1} = X_i^k + V_i^{k+1} \tag{1}$$

$$V_i^{k+1} = \omega V_i^k + c_1 rand_1 x (Pbest_i^k - X_i^k) + c_2 rand_2 x (Gbest^k - X_i^k) \tag{2}$$

$$w = w_{max} - \frac{w_{max} - w_{min}}{Iter_{max}} x Iter \tag{3}$$

with :

- V_i^k = individu velocity i at iteration k
- w = weight parameter
- c_1, c_2 = acceleration coefisien
- $rand_1, rand_2$ = random value between 0 and 1
- X_i^k = individu position i at iteration k
- $Pbest_i^k$ = $Pbest$ individu i until iteration k
- $Gbest^k$ = $Gbest$ community until iteration k
- w_{min}, w_{max} = initial and final weight
- $Iter_{max}$ = maximum iteration number
- $Iter$ = number of iteration now

III. SIMULATION AND ANALYSIS

A. Plant Data

The Plant used for simulation is the 500 kV Java-Bali Power System as shown in Fig. 6. The data of generator characteristics and cost, line impedances and an operating condition are shown at Tables I-III.

TABLE I
GENERATOR DATA

Unit	Caracter function of Generation	Production Cost (R/KWh)
1(Suralaya)	$100 + 101 P1 + 30 P1^2$	400
4(Muara Tawar)	$20264 + 25 P2 + 10 P2^2$	350
2(Cirata)	$0 + 20 P3 + 0$	250
11(Saguling)	$0 + 5.5P4 + 0$	250
17(Gresik)	$1996 + 219.5 P5 + 60 P5^2$	350
18(Grati)	$1854 + 516 P6 + 24 P6^2$	350
20(Paiton)	$11821 + 103 P7 + 30 P7^2$	350

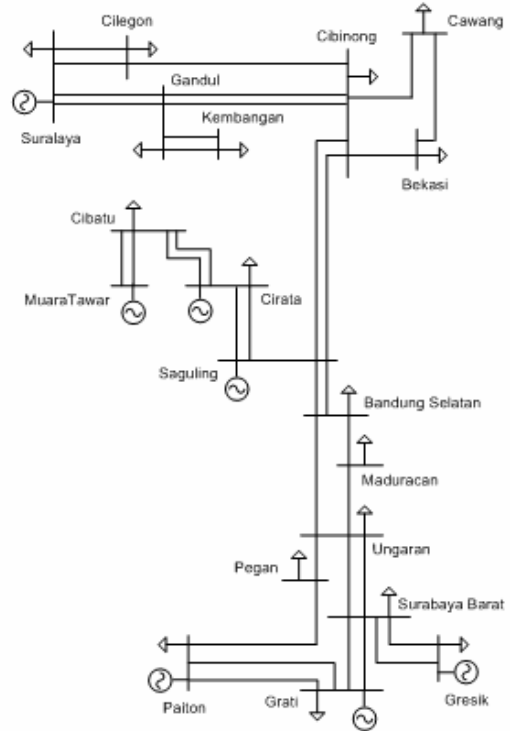

Fig. 6 500 kv Java Bali power system

TABLE II
NETWORK DATA

No.	Line	Z (ohm/km/fasa)	C (mF/km)	Distance (km)
1	Suralaya – Gandul	0.0293+j0.2815	0.01283	111.00
2	Suralaya – Cilegon	0.0251+j0.2808	0.01289	12.48
3	Cilegon – Cibinong	0.0293+j0.2815	0.01283	116.00
4	Gandul – Cibinong	0.0293+j0.2815	0.01283	21.30
5	Gandul – K.bangan	0.0251+j0.2808	0.01289	31.90
6	Cibinong – Saguling	0.0293+j0.2815	0.01283	80.30
7	Cibinong – Bekasi	0.0293+j0.2815	0.01283	37.92
8	Cibinong – Cawang	0.0293+j0.2815	0.01283	57.00
9	Cawang – Bekasi	0.0293+j0.2815	0.01277	18.00
10	M.Tawar – Cibatu	0.0293+j0.2788	0.01283	55.00
11	Cibatu – Cirata	0.0293+j0.2815	0.01283	44.56
12	Cirata – Saguling	0.0293+j0.2815	0.01289	25.10
13	Saguling - Bdg	0.0251+j0.2808	0.01283	37.43
14	Bdg - Ungaran	0.0293+j0.2815	0.01283	342.80
15	Bdg – Maduracan	0.0293+j0.2815	0.01283	130.00
16	M. racan – Ungaran	0.0293+j0.2815	0.01283	228.68
17	Ungaran – Krian	0.0293+j0.2815	0.01283	251.00
18	Ungaran – Padan	0.0293+j0.2788	0.01277	75.00
19	Krian – Grati	0.0251+j0.2808	0.01289	74.00
20	Krian – Gresik	0.0293+j0.2788	0.01277	22.20
21	Grati – Paiton	0.0251+j0.2808	0.01289	74.00
22	Paiton – Padan	0.0293+j0.2788	0.01277	410.00

TABLE III
OPERATING CONDITION

No	Bus	Total Power			
		P Load (MW)	Q Load (MVar)	P Gen (MW)	Q Gen (MVar)
1	Suralaya	199	58	3,118	762
2	Cilegon	387	87	-	-
3	Kmbangan	638	200	-	-
4	Gandul	730	189	-	-
5	Cibinong	560	-47	-	-
6	Cawang	599	214	-	-
7	Bekasi	545	71	-	-
8	M. Tawar	1	-	477	185
9	Cibatu	669	206	-	-
10	Cirata	612	323	650	313
11	Saguling	-	3	762	193
12	Bdg Sel.	638	-108	-	-
13	Maduracn	321	143	-	-
14	Ungaran	875	-211	-	-
15	Pedan	302	-386	-	-
16	Kediri	340	709	-	-
17	Gresik	176	231	454	200
18	Sby Barat	341	33	-	-
19	Grati	252	229	60	21
20	Paiton	493	435	3,099	606

The software used for simulation was Matlab and Newton Raphson was chosen as load flow algorithm. The neural network used was constructive back propagation and the PSO used was standard PSO. As many as fifty populations were selected as initial population.

B. Result and Analysis

The input and target data for developing NN model of generator capability curve were created by sampling the angle θ between $0^\circ - 180^\circ$ and the related distance R. As many as one hundred data for each generator were used for developing NN model. The procedure explained at II.A was applied to each generator. The curve resulted by NN-model together with the original curve are shown at Fig. 7 for generator Paiton. The other generators are left for simplicity. As can be seen, both curves are very similar except for a very view operating point. This means that the NN model can reconstruct exactly the original curve and ready used for OPF constraint.

The accuracy justification of generator security check algorithm is shown at Table IV and Fig. 8. Generator Suralaya is used as an example. The table show very accurate identification of security level of the generator.

Fig. 9 shows the convergence of the learning process of generator Cirata. It can be concluded that finally all population converge to the same value. The evolution of the objective function (cost/hr) is shown at Fig. 10. The optimal solution resulted was compared with the result using conventional constraint as shown at Table V. As can be seen, the proposed method give lower total operating cost but operates at more marginal operating point. Figs. 11-13 shows this phenomenon for three generators.

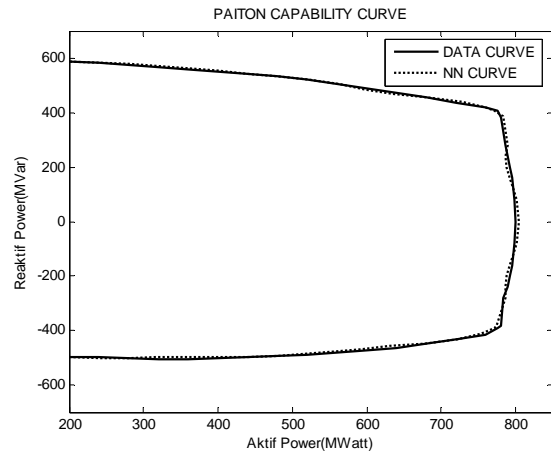

Fig.7 Paiton Capability Curve

TABLE IV
GENERATOR SECURITY CHECK

	P(MW)	Q(MAR)	SECURITY
TRIANGLE	4500	3000	NOT OK
CIRCLE	4320	2616	OK
PLUS	3000	1000	OK

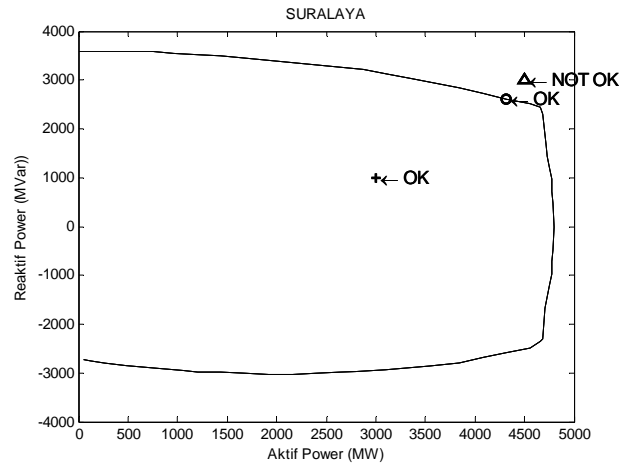

Fig. 8 Generator Security Check

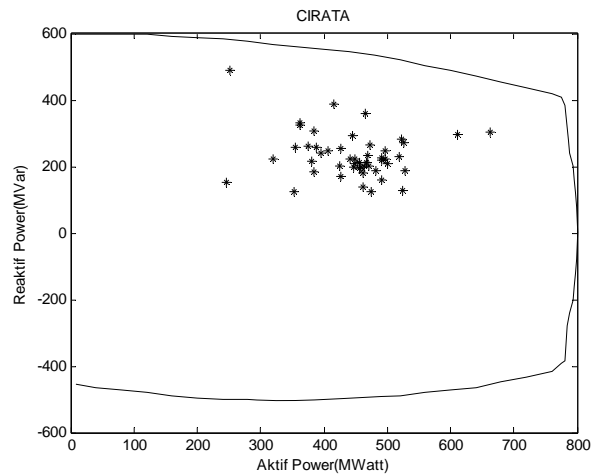

Fig. 9a Convergent Process at iterations = 2

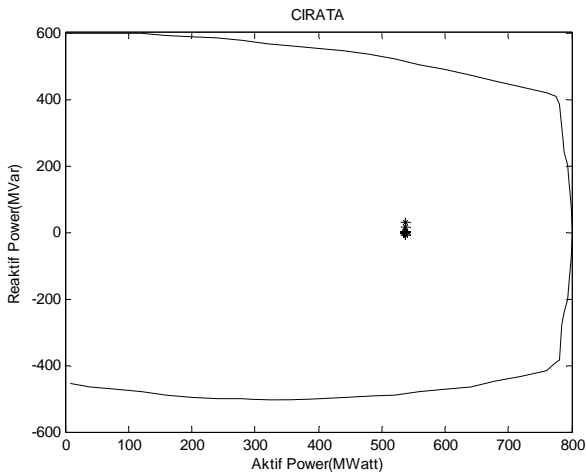

Fig. 9b Convergent Process at iterations = 50

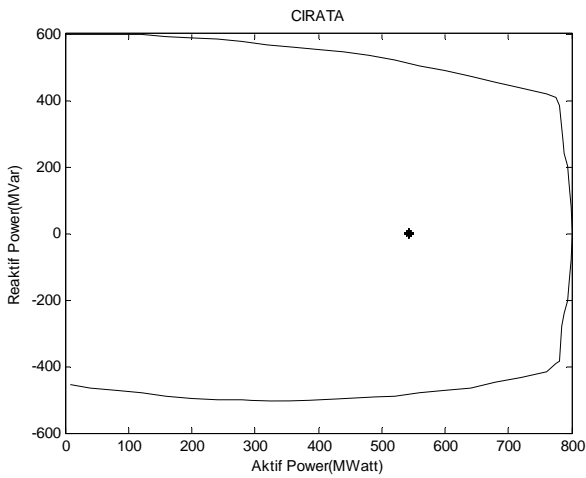

Fig. 9c Convergent Process at iterations = 150

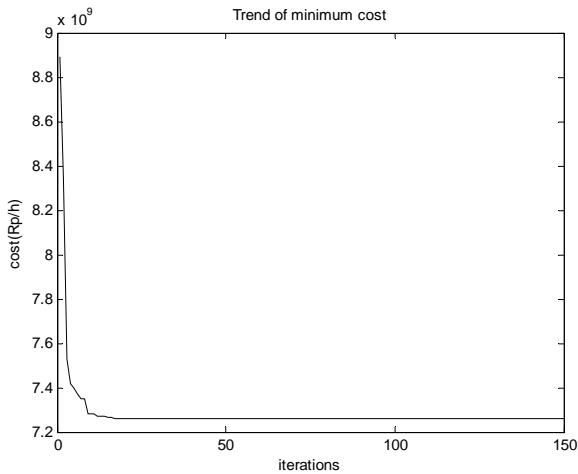

Fig. 10 Trend of PSO to find minimum cost

TABLE V
COST OF GENERATIONS

PSO WITH CONSTRAINT CURVE			PSO WITH CONSTRAINT MIN-MAX		
P(MW)	Q(MVar)	COST	P(MW)	Q(MVar)	COST
2997.5	767.88	3.2348e+009	3335	2490.9	4.0041e+009
493.03	228.56	8.5192e+006	477	185	7.9748e+006
543.43	2.3e-005	2717.2	650	313	3250
804.23	0.75598	1105.8	762	193	1047.8
502.65	0.47248	3.1838e+008	454	200	2.5974e+008
70.37	0.066148	1.0117e+006	60	21	7.3724e+005
3425.7	3011.2.2	3.6969e+009	3099	606	3.0253e+009
Total Cost		7.2595e+009	Total Cost		7.2978e+009

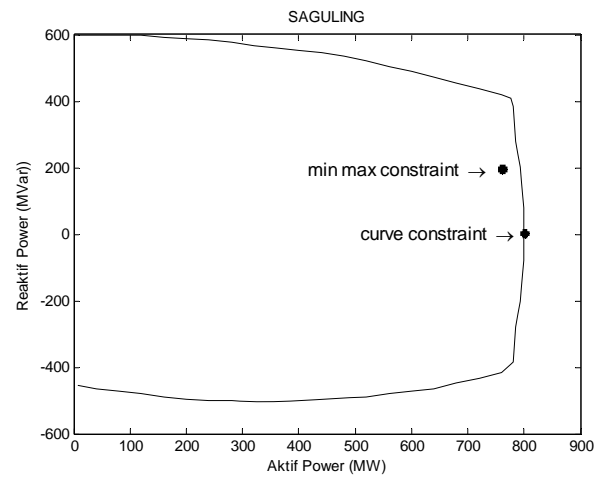

Fig. 11 The P-Q position of Saguling generator

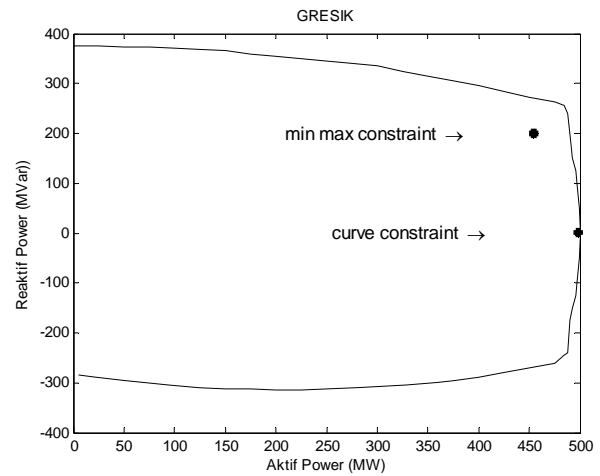

Fig. 12 The P-Q position of Gresik generator

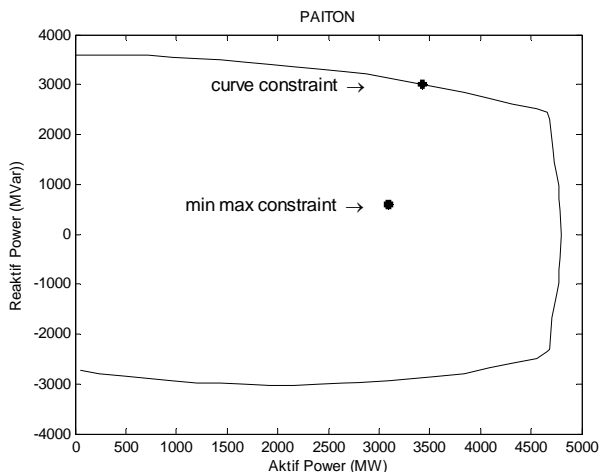

Fig. 13 The P-Q position of Paiton generator

IV. CONCLUSION

The proposed method containing capability curve constraint successfully reduces the operating cost compared with conventional constraint. The most additional valuable characteristic of the proposed method is its simplicity and flexibility in changing the constraint when there is a change in the curve limit especially related to under excitation operation limit. It is very useful to assist the engineer to minimize their power system operation cost as well as to maintain safety level of each generator connected to the system.

ACKNOWLEDGMENT

Thank you for the Indonesian Government Electrical Company and JICA-PREDICT for supporting all the data and financial needed in this research.

REFERENCES

- [1] Sudhakaran, M., Palanivelu, T.G., "GA and PSO culled hybrid technique for economic dispatch problem with prohibited operating zones", *Journal of Zhejiang University*, ISSN 1673-565X, pp. 896 – 903, 2007.
- [2] Pablo, E., Juan, M.R., "Optimal Power Flow Subject to Security Constraints Solved With a Particle Swarm Optimizer", *IEEE Transactions On Power Systems*, Vol. 23, No. 1, pp. 33 – 40, 2008.
- [3] Gaing, Z.L., Particle swarm optimization to solving the economic dispatch considering the generator constraints, *IEEE Trans. On Power System*, Vol 18. No. 3, pp. 1187 – 1195, 2003.
- [4] Zimmerman, D. Ray, Murilloa E. Carlos, *User's Manual A Matlab Power System Simulation Package*, Version 3.2 – September 21, PSERC, 2007.
- [5] Boukir, T., Labdani, R., "Economic power dispatch of power system with pollution control using multiobjective particle swarm optimization", *University of Sharjah Journal of Pure & Applied Sciences*, Vol.4. No.2, pp. 57 – 73, 2007.
- [6] Wang, C.R., Yuan, H.J., "A modified particle swarm optimization algorithm and its application in optimal power flow problem", *Proceedings of the fourth International Conference on machine learning and Cybernetics*, Guangzhou, 2005.
- [7] Balci, H.H, Valenzuela, J.F., "Scheduling electric power generators using particle swarm optimization combined with the lagrangian relaxation method", *AMCS Appl.Math.Comput.Sci*, Vol.14. No. 14, pp. 411 – 421, 2004.
- [8] Kumari, M.S., Sydulu, M., "An Improved Evolutionary Computation Technique for Optimal Power Flow Solution", *International Journal of Innovations in Energy Systems and Power*, Vol. 3, no. 1, pp. 32 – 45, 2008.

- [9] Younes, M., Rahliga, M., "GA Based Optimal Power Flow Solutions", *Electrical & Instrumentation Engineering Department*, Thapar University, 2008.
- [10] Piccolo, A., Vaccaro, A., "Fuzzy Logic Based Optimal Power Flow Management in Parallel Hybrid Electric Vehicles", *Iranian Journal of Electrical and Computer Engineering*, Vol. 4, no. 2, pp. 85 – 93, 2005.
- [11] Wong, K.P., Wong, S.Y.W., "Combined Genetic Algorithm/ Simulated Annealing /Fuzzy Set to Short Term Generation Scheduling with Take-or Pay Fuel Contract", *IEEE Trans. Power Systems*, Vol.11, No.1, pp. 128-136, 1996.
- [12] Wong, K.P., Wong, S.Y.W., "Hybrid Genetic/Simulated Annealing to Short Term Multiple Fuel-Constrained Generation Scheduling", *IEEE Trans. Power Systems*, Vol.12, No.2, pp. 776-784, 1997.

Mat Syai'in was born in Indonesia. He received the B.E. degree in engineering physics and M.S degree in electrical engineering from Sepuluh Nopember Institute of Technology, Surabaya, Indonesia, in 2003 and 2008, respectively.

Since 2008, he has been a Lecturer in the Shipbuilding State Polytechnics, Sepuluh Nopember Institute of Technology, Surabaya, Indonesia. He is now finishing doctoral degree at the same institute under the topic artificial intelligence optimal power system operation, monitor and control.

Adi Soeprijanto was born in Indonesia. He received the B.E., and M.S., degrees in electrical engineering from Bandung Institute of Technology, Bandung, Indonesia, in 1988 and 1995, respectively. He received the Ph.D degree in electrical engineering from Hiroshima University in 2001.

Since 1990, he has been a Lecturer in the Department of the Electrical Engineering, Sepuluh Nopember Institute of Technology, Surabaya, Indonesia. His current research interests include the application of intelligent systems to power system operation, management, and control.

Dr. Ir. Adi Soeprijanto, MT is a member of the Indonesian Power System Expert Association (IATKI) of Indonesia.

Takashi Hiyama (M'86–SM'93) was born in Japan. He received the B.E., M.S., and Ph.D. degrees in electrical engineering from Kyoto University, Kyoto, Japan, in 1969, 1971, and 1980, respectively.

Since 1989, he has been a Professor in the Department of the Electrical and Computer Engineering, Kumamoto University, Kumamoto, Japan. His current research interests include the application of intelligent systems to power system operation, management, and control.

Prof. Hiyama is a member of the Institute of Electrical Engineers of Japan, the Society of Instrument and Control Engineers (SICE) of Japan, and the Japan Solar Energy Society.