

Hydrodynamic Characteristics of Weis–Fogh Type Ship’s Propulsion Mechanism Having Elastic Wing

K. D. Ro, J. T. Park, and J. H. Kim

Abstract—This experiment was conducted in attempt of improving hydrodynamic efficiency of the propulsion mechanism by installing a spring to the wing so that the opening angle of the wing in one stroke can be changed automatically, compared to the existing method of fixed maximum opening angle in Weis-Fogh type ship propulsion mechanism. Average thrust coefficient was almost fixed with all velocity ratio with the prototype, but with the spring type, thrust coefficient increased sharply as velocity ratio increased. Average propulsive efficiency was larger with bigger opening angle in the prototype, but in the spring type, the one with smaller spring coefficient had larger value. In the range over 1.0 in velocity ratio where big thrust can be generated, spring type had more than twice of propulsive efficiency increase compared to the prototype.

Keywords—Hydraulic Machine, Propulsion Mechanism, Fluid Force, Elastic Wing.

I. INTRODUCTION

THE Weis-Fogh mechanism[1],[2], which was discovered by the hovering flight of a small bee(*Encarsia Formosa*), is gathering attention of many scientists studying hydrodynamics for the unique and efficient lift generation mechanism[3~7]. Recently, engineering application of the mechanism is actively attempted as well [8]-[12]. Some scientists proposed a propulsion model that applied the principle of the mechanism, and conducted experiments on dynamic characteristics and driving test of a model ship, which showed that this propulsion mechanism worked very effectively as a new ship propulsion system[9]. Also, Some scientists visualized the unsteady flow field that was created around the wings when the propulsion mechanism was being operated[13], and verified the time variation of the thrust and the drag on the wing[14]. The weakest point of this mechanism is that while the efficiency of propulsion is high, the range of the velocity ratio that generates maximum propulsive efficiency is narrow, and the velocity

ratio is under 1, which means the thrust is relatively small. To put to practical use of this propulsion mechanism, supplementing this weak point is most important. To generate high thrust in the high velocity ratio range, changing the wing of propulsion mechanism from a hard, flat-plate to elastic body would make it possible. In fact, the wings of a small bee and the body of a fish are elastic, and there is enough possibility that elastic body contributes to the improvement in thrust. Therefore, in this study, we will attempt to improve the thrust, drag, and efficiency characteristics of the propulsion mechanism by using an elastic wing with attached spring which automatically adjusts the opening angle in one stroke.

II. EXPERIMENTAL METHOD

A. Model of Propulsion Mechanism

First, the model of the propulsion mechanism that will be used in this experiment is shown in Fig. 1.

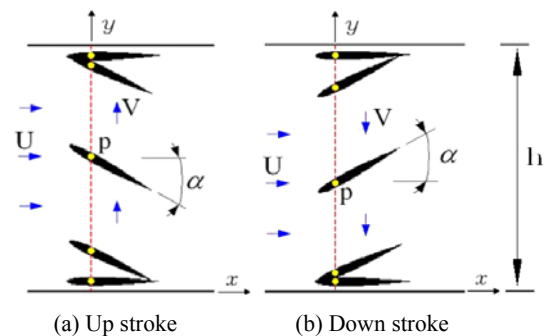

Fig. 1 A model of propulsion mechanism

The figure shows the model from upper perpendicular side; as one flat-plate wing works in a certain motion in the water channel, thrust is generated toward the left of the figure, which is the direction of the ship. As point P, which corresponds to the center shaft of the wing, oscillates perpendicular to uniform flow U and in the velocity of V, the wing first opens from the lower surface, then maintaining an opening angle of α , it moves translationally in parallel, and finally rotates and closes on the upper surface. Then, the wing repeats the motion by opening at the upper surface in rotation, moves in translation, and finally rotates and closes on the lower surface. Originally in the

K. D. Ro is professor in the Department of Mechanical System Engineering, Gyeongsang National University, Gyeongnam, 650-160 Republic of Korea (corresponding author to provide phone: +82-55-640-3123; fax: +82-55-640-3128; e-mail: rokid@gaechuk.gsnu.ac.kr).

J. T. Park, is graduate student in the Department of Mechanical System Engineering Gyeongsang National University, Gyeongnam, 650-160 Republic of Korea (e-mail: parkjit@hanmeil.net).

J. H. Kim, is graduate student in the Department of Mechanical System Engineering Gyeongsang National University, Gyeongnam, 650-160 Republic of Korea (e-mail: design81@hanmeil.net).

Weis-Fogh mechanism, one pair of wings open at a certain angle, and while maintaining the angle, each wing moves to the opposite direction of each other. But when seen from the body, the movement of the each wing can be considered as reciprocals. Therefore, by installing channel walls at the symmetrical line and executing the motion with a single wing as in Fig. 1, by the mirror effect, the identical effects can be achieved as the Weis-Fogh mechanism.

B. Measurement of the Thrust and Drag Acting on the Wing

The experiment is conducted by making a wing driving system that gives the same wing movement as the propulsion mechanism in Fig. 1, which is installed in the circulating water channel where uniform flow runs, and measuring thrust and drag on the wing. The schematic diagram of driving unit of the wing is shown in Fig. 2. The main structure of the system is made with acrylic board and aluminum angle bar, and the dimensions are 500mm in length and 650mm in width to fit into the circulating water channel. In the wing driving system, the shaft is fixed onto the slider and the slider is attached to one side of the belt so that when the motor (DC 30W) spins forth or backwards, the wing moves in an oscillating motion. The front and back spin of the motor is operated by a limit switch and a relay circuit installed at the ends of the slider rail, and the velocity of the wing movement is controlled with adjusting the spin speed of the motor. The wing used in this experiment was made in the shape of NACA0010; as shown in Fig. 3, the size of the wing is chord $C=100\text{mm}$, and its span 160mm . The shaft was penetrated at the point of $0.75C$ away from trailing edge of the wing through a hole of 3mm in diameter.

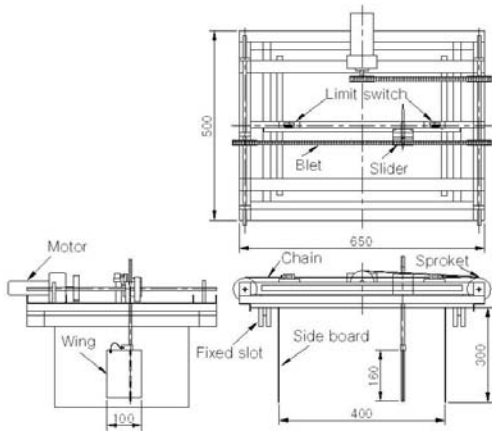

Fig. 2 Driving unit of the wing (unit:mm)

The shaft was made with a titanium bar, 9mm in diameter. The wing is inserted in the shaft of the wing so that when the slider moves in a reciprocating motion, a momentum around the shaft works toward the wing to open it, and in the closing stage, the leading edge of the wing collides with the side board, forcing it to close. In this experiment, two types of wings were

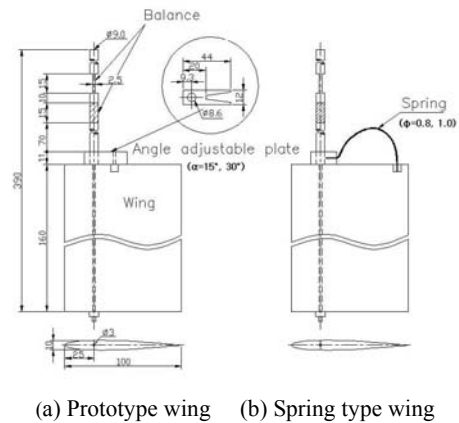

Fig. 3 Structure of the wing and shaft (unit:mm)

TABLE I
THE SPRING COEFFICIENTS OF EACH ELASTIC WING

| The diameter of spring (ϕ) | $\phi = 0.8\text{mm}$ | $\phi = 1.0\text{mm}$ |
|-----------------------------------|-----------------------|-----------------------|
| Spring coefficient (N-m/rad) | 0 . 0 8 8 4 | 0 . 1 1 8 5 |

used as shown in Fig. 3 (a) and (b). Maximum opening angle α is fixed in (a), and $\alpha=15^\circ, 30^\circ$ angle adjustment plate was made. (b) was made so that opening angle α was automatically adjusted by the water resistance applied on the wing when it moved; in other words, two kinds of steel line, diameter of $\phi=0.8, 1.0$, were bent to function as springs as shown in Fig. 3 (b). The ultimate point of this experiment is to improve propulsive efficiency by adjusting opening angle with the water resistance, instead of prototype's fixed opening angle in Weis-Fogh type propulsion mechanism. The measurement of the spring coefficient of each spring is shown in Table I.

Thrust and drag was measured by cutting the balance, or top of the shaft, evenly in front, back, right and left, as shown in Fig. 3, and by attaching 4 strain gauges, thrust and drag was measured by deformation of these gauges. In other words, the voltage waveforms from the strain gauge comes out as the value of thrust and drag by pre-compensated coefficient on a personal computer, through a bridge circuit, strain amplifier and A/D converter in each channel(2 channels in total).

The experiment fixed maximum opening angle α at 15° and 30° , changed uniform flow $U(U=0.049\sim 0.349\text{m/s})$ and wing movement velocity $V(V=0.055\sim 0.246\text{m/s})$ at regular intervals to prototype wing and spring type which automatically adjusts opening angle, measured the time variation of thrust and drag, and yielded average thrust coefficient, average drag coefficient, and average propulsive efficiency by averaging the values in one cycle. The range of Reynolds number is $Re=7.2\times 10^3\sim 3.9\times 10^4$ when wing chord was fixed as unit length and yielded by uniform flow U .

C. Definition of the Characteristic

Each coefficient that shows the hydrodynamic characteristic of this propulsion mechanism, that is, thrust coefficient C_T and drag coefficient C_D is defined as follows, by wing movement velocity V .

$$C_T = \frac{T}{\frac{1}{2}\rho V^2 S} \quad (1)$$

$$C_D = \frac{D}{\frac{1}{2}\rho V^2 S} \quad (2)$$

T represents thrust, D for drag, ρ for the density of the fluid, and S for the wing area below the water surface. As defined in Fig. 4, thrust T is in the direction of the progress of the ship, which is the opposite direction of uniform flow U . Drag D is the opposite direction of wing movement velocity V .

Also, the average propulsive efficiency of the mechanism $\bar{\eta}$ is the power applied to the wing, namely the percentage of the net output generated from the wing to input, and is calculated as follows:

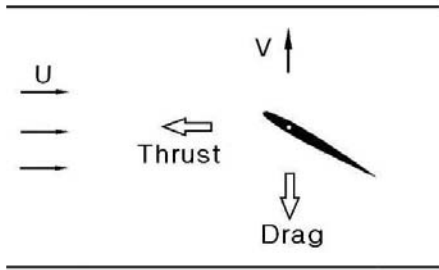

Fig. 4 Definitions of thrust and drag

$$\bar{\eta} = \frac{\int_0^{T_c} C_T U dt}{\int_0^{T_c} C_D V dt} \times 100 \quad (3)$$

Here T_c represents the period of one cycle of wing movement.

III. RESULTS AND DISCUSSIONS

First, in one stroke of each spring type elastic wing illustrated in Table I, the change of opening angle according to wing position change is shown in Fig. 5. Here, x-axis expresses the dimensionless value of wing moving distance y to the width of the channel h ; as shown in the figure, although there are some differences according to the velocity ratio V/U and the spring coefficient, the change of opening angle according to the wing position change in the channel is very big when the wing leaves from the channel surface, then the opening angle decreases until it comes to a certain angle where it stabilizes and moves translationally, then finally, when the wing approaches the other side of the channel, it opens up a little bit

before it closes. The change of thrust coefficient C_T and drag coefficient C_D over 2 reciprocating movements of the wing at velocity ratio $V/U=1.0$ is shown in Fig. 6.

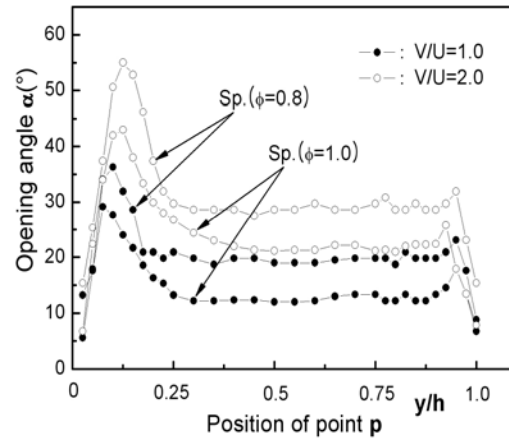

Fig. 5 Variations for opening angle according to the wing position in a stroke for each spring type elastic wing

The dotted line in the figure expresses the prototype flat-plate wing with maximum fixed angle at $\alpha=15^\circ$, and the solid line expresses the spring type elastic wing that adjusts opening angle by using steel line of $\phi=1.0$ used as spring. In the figure, the x-axis expresses the traveling distance of wing shaft normalized by the channel width; this value means the number of strokes. First, looking at the change of thrust coefficient, the value is + through the whole stroke except for the opening stages, which means regardless of the wing's reciprocating motion, thrust occurs toward the direction of the progress of the ship. However, when comparing the dotted and solid lines, in dotted line, there are some fluctuations but have relatively constant value, whereas solid line decreases after having a large value at the beginning of the stroke. This is because when the wing moves from opening stage to translational stage, during opening, the negative pressure side of the wing, that is, the wing takes off from the wall where the pressure between the wing and the channel wall is much lower than the pressure toward the moving direction. As a result, a vortex is released from the trailing edge of the wing. In fact, in the prototype case, during the opening in visualization experiment [13] of the flow field, fluid is inhaled because of the negative pressure between the wing and the wall, and through numerical calculation [14], we confirmed that vortex was released from the trailing edge of the wing in translational stage. But in the spring type case, a momentum is applied because of the spring; therefore before it takes off, the wing has to open up to a larger angle as the trailing edge of the wing touches the wall, which we can assume that right before take off, the pressure difference of both sides of the wing should be smaller than in the prototype. Therefore in the spring type case, the wing can shift over to translational stage with effective Weis-Fogh mechanism.

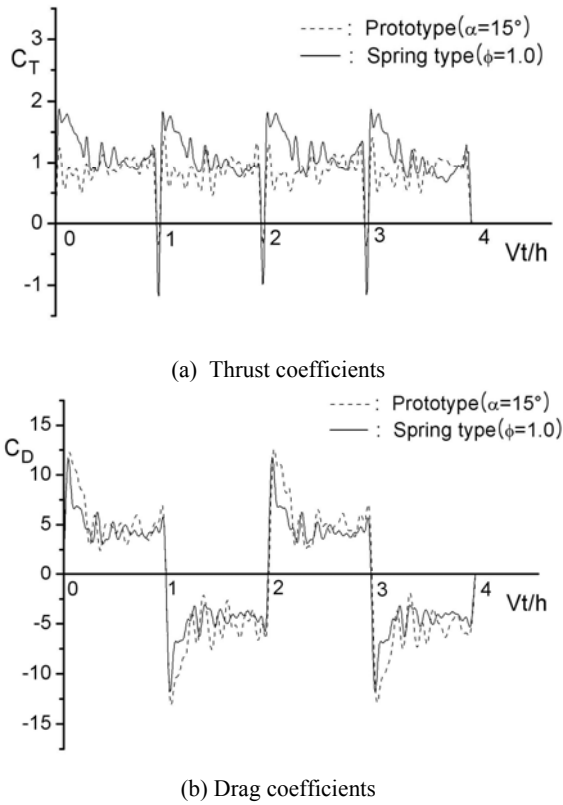

Fig. 6 Time variations for thrust and drag coefficients ($V/U=1.0$)

Meanwhile, when looking at the change of drag coefficient (b), in each stroke, the value is reversed with x-axis; this is because each stroke of wing movement is in opposite direction. Solid line of the drag coefficient is smaller than dotted line, but the difference is very small. This is because with elastic wing, the opening angle increases little bit because of water resistance during wing movement. Especially water resistance increases in the closing stage, but as shown in Fig. 5, opening angle opens automatically by spring, which prevents decrease of propulsive efficiency that occur with drag increase.

(a) Average thrust coefficient and (b) Average drag coefficient with the change in velocity ratio V/U of prototype wing with the maximum opening angle of $\alpha=15^\circ$ and spring type elastic wing with $\phi=1.0$ spring is shown in Fig. 7. Each point in (a) and (b) in the figure corresponds with the average value of 1 cycle in Fig. 6 of (a) and (b). First, when looking at the distribution of average thrust coefficient, with the prototype ($\alpha=15^\circ$), the values are almost constant regardless of the velocity ratio. Compared to this, with spring type ($\phi=1.0$), the value increases sharply as the velocity ratio increases. In the former type, the opening angle does not change even though the velocity ratio increases; but in the latter, as explained before in Fig. 6, as velocity ratio increases, the opening angle right before the translational stage increases sharply as shown in Fig. 5 to have impressive Weis-Fogh effect. Also, when looking at the distribution of average drag coefficient, over velocity ratio of 1, the differences between the values are increasing little bit as velocity ratio increases; this is because in the spring type

case, opening angle increases as velocity ratio increases, which led to decrease in average drag. On the other hand, where the velocity ratio is small, especially under 0.5, as velocity ratio decreases, average thrust coefficient is similar in both types, whereas the average drag coefficient increases in both. This is because in this range, water resistance is small which makes the opening angle to be small.

(a) Average thrust coefficient and (b) Average drag coefficient with the change in velocity ratio V/U of prototype wing with the maximum opening angle of $\alpha=30^\circ$ and spring type elastic wing with $\phi=0.8$ spring is shown in Fig. 8. The spring coefficient is smaller than the one in Fig. 7; therefore at the same velocity ratio, even if the opening angle is big, the tendency in change of average thrust coefficient and average drag coefficient according to the velocity ratio is same. The average thrust coefficient of prototype ($\alpha=30^\circ$) is 1.0, which is constant regardless of the velocity ratio. However, with the spring type ($\phi=0.8$), the value increases sharply as the velocity ratio increases. Only it did not increase in a straight line because the spring coefficient was too small, so that the increase in opening angle with velocity ratio exceeded the range of elasticity. Meanwhile, the distribution of the average drag coefficient was both similar in tendency with velocity ratio as Fig. 7, but the absolute value was smaller in the spring type than the prototype. This is because in the spring type, as velocity ratio increases, the opening angle increased also, which led to the decrease of average drag.

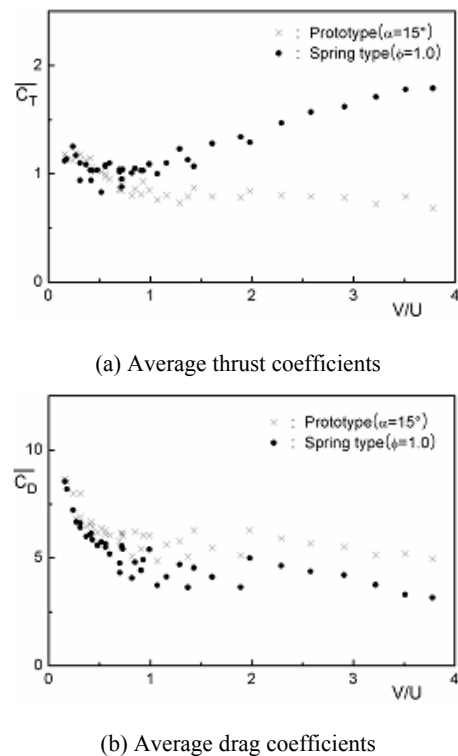

Fig. 7 Average thrust and drag coefficients with velocity

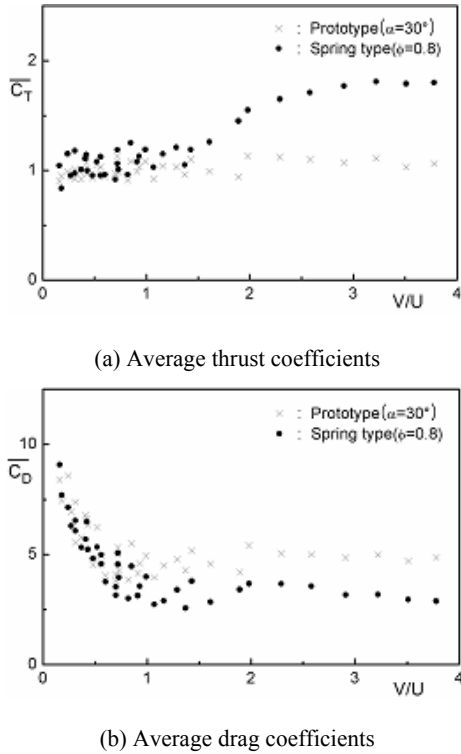

Fig. 8 Average thrust and drag coefficients with velocity ratio

Average propulsive efficiency of various types of wings with the change in velocity ratio V/U is shown in Fig. 9. When the velocity ratio is over 1, with the prototype where the maximum opening angle is constant, the one with big opening angle has larger average propulsive efficiency; with the spring type where the opening angle changes, the one with small spring coefficient has larger value. Especially over the velocity ratio of 1.5 where large thrust can be generated, by automatically adjusting the opening angle with a spring, propulsive efficiency can be increased over twice of the existing fixed angle type. Therefore, practical application of the propulsion mechanism is anticipated, which can greatly complement the weakness of low propulsive efficiency of the prototype in the large velocity ratio range.

IV. CONCLUSION

This study was conducted in attempt of improving hydrodynamic efficiency of the propulsion mechanism by installing a spring to the wing so that the opening angle of the wing in one stroke can be changed automatically, compared to the existing method of fixed maximum opening angle in Weis-Fogh type ship propulsion mechanism. There were 2 prototypes of wing with the maximum opening angle of $\alpha=15^\circ$ and $\alpha=30^\circ$, and 2 types of elastic wing with different spring coefficients. By changing the velocity ratio V/U , thrust, drag, and propulsive efficiency were examined experimentally. The summaries of results are as follows:

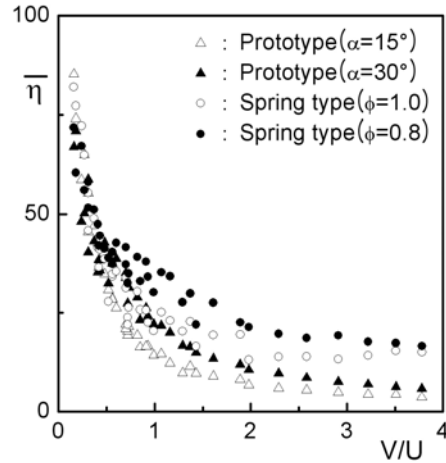

Fig. 9 Average propulsive efficiency with velocity ratio for wings of various type

- (1) With the spring type, the opening angle has large value when moving from opening stage to the translational stage, and moving from translational stage to closing stage.
- (2) Average thrust coefficient was constant with the prototype with all velocity ratio, but it increased sharply with the spring type as velocity ratio increased.
- (3) Average drag coefficient with velocity ratio was similar in the tendency with each other, but the absolute value was smaller in the spring type than the prototype.
- (4) Average propulsive efficiency was larger with the bigger opening angle of the prototype, and with the smaller spring coefficient of the spring type.
- (5) In the range of velocity ratio over 1.5 where large thrust can be generated, the spring type showed over twice of the propulsive efficiency than the prototype.

ACKNOWLEDGMENT

This work was supported by the Korea Science and Engineering Foundation (KOSEF) grant funded by the Korea government (MOST) (No. R01-2007-000-10038-0).

REFERENCES

- [1] Weis-Fogh, T., "Quick Estimates of Flight Fitness in Hovering Animals, Including Novel Mechanism for Lift Production", *Journal of Experimental Biology*, Vol.59, pp.169-230, 1973.
- [2] Lighthill, M. J., "On the Weis-Fogh Mechanism of Lift Generation", *Journal of Fluid Mechanics*, Vol.60, Part 1, pp.1-17, 1973.
- [3] Maxworthy, T., "Experiments on the Weis-Fogh Mechanism of Lift Generation by Insects in Hovering Flight. Part 1. Dynamics of the 'Fling'", *Journal of Fluid Mechanics*, Vol.93, pp.47-63, 1979.
- [4] Edwards, R. H. and Cheng, H. K., "The Separation Vortex in the Weis-Fogh Circulation-Generation Mechanism", *Journal of Fluid Mechanics*, Vol.120, pp. 463-473, 1982.
- [5] Spedding, G. R. and Maxworthy, T., "The Generation of Circulation and Lift in a Rigid Two-Dimensional Fling", *Journal of Fluid Mechanics*, Vol.165, pp.247-272, 1986.
- [6] Ro, K. D. and Tsutahara, M., "Numerical Analysis of Unsteady Flow in the Weis-Fogh Mechanism by the 3D Discrete Vortex Method with

- GRAPE3A”, Transactions of the ASME, Journal of Fluids Engineering, Vol.119 pp.96-102, 1997.
- [7] Zhang Shesheng, et, “Research and progress of Weis-Fogh mechanism hydrodynamics”, Journal of Hydrodynamics, Vol.3, pp.55-60, 1999.
- [8] Furber, S. B. and Ffowcs Williams, J. E., “Is the Weis-Fogh Principle Exploitable in Turbomachinery?”, Journal of Fluid Mechanics, Vol.94, Part 3, pp.519-540, 1979.
- [9] Tsutahara, M. and Kimura, T., “An Application of the Weis-Fogh Mechanism to Ship Propulsion”, Transactions of the ASME, Journal of Fluids Engineering, Vol. 109, pp. 107-113, 1987.
- [10] Tsutahara, M. and Kimura, T., “A Pilot Pump using the Weis-Fogh Mechanism and its Characteristics”, Transactions of the JSME, Vol.54, No.498, pp.393-397, 1987.
- [11] Tsutahara, M. and Kimura, T., “Study of a Fan Using the Weis-Fogh Mechanism (An Experimental Fan and Its Characteristics)”, Transactions of the JSME, Vol.60, No.571, pp.910-915, 1994.
- [12] Zhang S. S., “Hydrodynamic model of Weis-Fogh mechanism hydrofoil”, Journal of Hydrodynamics, Vol.4. pp.35-39, 1996.
- [13] Ro, K. D., Kim, K. S. and Kim, J. H., “The Flow Characteristics around Airfoil Moving Reciprocally in a Channel”, Transactions of the KSME, Vol.32, No.7, pp. 536-541, 2008(in Korean).
- [14] K. D. Ro, B. S. Zhu and H. K. Kang, “Numerical Analysis of Unsteady Viscous Flow Through a Weis-Fogh Type Ship Propulsion Mechanism Using the Advanced Vortex Method”, Transactions of the ASME, Journal of Fluids Engineering, Vol. 128, pp.481-487, 2006.