

Rethinking the Analysis of Means-End Chain Data in Marketing Research

P. Puustinen, and A. Kanto

Abstract—This paper proposes a new procedure for analyzing means-end chain data in marketing research. Most commonly the collected data is summarized in the Hierarchical Value Map (HVM) illustrating the main attribute-consequence-value linkages. This paper argues that traditionally constructed HVM may give an erroneous impression of the results of a means-end study. To justify the arguments, an alternative procedure to (1) determine the dominant attribute-consequence-value linkages and (2) construct HVM in a precise manner is presented. The current approach makes a contribution to means-end analysis, allowing marketers to address a set of marketing problems, such as advertising strategy.

Keywords—Means-end chain analysis, Laddering, Hierarchical Value Map.

I. INTRODUCTION

SINCE the 1980s, the means-end chain approach and laddering technique has been well-rooted in marketing research. [1], [2], [3] According to [4] p.8, the attractiveness of the means-end chain approach rests on the fact that, “it’s founded in the theory of consumer behavior and, at the same time, provides guidance for the development of marketing strategies”. While there is available a considerable amount of empirical work on means-end chains, there are still many unresolved issues regarding the means-end chain approach and analysis.

The means-end chain approach was developed as a way to understand consumers’ cognitive structures in relation to decision-making and engagement in experiences. [5], [6] It provides the basis for understanding the cognitive linkages between specific situational knowledge (attributes and consequences), and self-knowledge (consequences and values) [7]. The linkages from meanings to values are seen to be hierarchically structured as attributes - consequences - values [8]. For example, Barbados as a holiday destination choice may have the attribute “English as an official language”. To a consumer “English as an official language” means that Barbados delivers the consequence (benefit) of “social atmosphere”. In turn, the consequence “social atmosphere” helps the consumer to fulfill a personal value, to

P. Puustinen is with University of Tampere, Department of Law, 33014 University of Tampere Finland (corresponding author to provide e-mail: pekka.puustinen@uta.fi).

A. Kanto is with University of Tampere, Department of Law, 33014 University of Tampere Finland.

The authors would like to thank the Finnish Foundation for Economic Education for funding of this project.

feel a sense of “belonging”.

Most commonly the results of means-end chain studies are summarised in an aggregate map of cognitive structure called a Hierarchical Value Map (HVM) illustrating the main attribute-consequence-value linkages. This so-called mind map diagram aims to provide an efficient representation of the voice of the consumer, helping marketing decision-makers to be better able to understand their customers. [9]

The way the means-end chain approach has been applied has been recently questioned. For example, assumed asymmetric structure, where the focus is on the top of the hierarchy, has been tested by [10]. According to their findings the means-end structure is rather a network, in which there are one or more central concepts (cf. nodes in a HVM) which are not necessarily end values. The pure hierarchical structure was also questioned by [11]. Reference [11] argues that not all levels of abstraction necessarily affect the choice procedure).

The aim of this paper is to improve the analysis of means-end chain data and the graphic presentation of results of means-end results. Inspired by recent findings [10], [11], the focus is on developing a new conceptual procedure to determine the dominant means-end chains and central nodes, and to construct an accurate HVM. If a more advanced method for analyzing means-end data can be developed, then the means-end chain approach would be a more powerful tool for marketers to address a set of marketing problems, such as advertising strategy. The paper is structured as follows. The next section briefly summarizes the conventional method [12] used in means-end chain data analysis. The deficiency of conventional method is briefly attested in the third section followed by a presentation of a new procedure to analyze means-end chain data. A discussion concerning the limitations and marketing implications concludes the paper.

II. IDENTIFYING MEANS-END CHAINS

Means-end chains are most commonly revealed with the help of a laddering technique. Laddering is a technique that aims to identify how consumers translate the attributes of products/services into meaningful association with respect to self, following the means-end approach (for a detailed discussion of the method, see [12]). Laddering proceeds by asking each respondent “why is that important to you” on each evoked concept, forcing this person to climb the ladders of the mind. The process continues until the ladder has reached a level of abstractness from which it is impossible to continue.

Hence, in “hard laddering” (paper-and-pencil tasks) as well as in “soft laddering” (interviews), the technique forces respondents to elaborate their answers in an increasingly abstract way [13]. The technique seeks to ascertain the attributes that the consumer uses to distinguish the product or service, to determine the consequences of these attributes, and to evaluate how these, in turn, relate to desired values, represented by ladders. [14]

Once means-end data has been collected through laddering interviews, the first step of means-end chain analysis is to transform conversational means-end data into separate phrases and then conduct a content analysis of the elements selected. For illustrating means-end analysis, we generated 78 complete means-end chains (complete cognitive structures) and total sum 134 synthetic relations between 7 attributes, 7 consequences, and 5 values to represent content analyzed means-end data. Based on the recommendations of earlier studies (e.g. [12], [15]), an implications matrix was constructed to be used as the basis for identifying which constructs would be included in the HVM. The implication matrix scored the attribute - consequence - value relations by breaking down the synthetic ladders into aggregated chains.

From the aggregated data in the implication matrix, chains were then reconstructed to form an HVM. Next the cut-off level of 3 was established and all connections below this level were ignored. Direct and indirect relations were included in the HVM. The final HVM (see Fig. 1) was represented virtually in the fashion recommended by [9]. In so doing the 6 attributes, 5 consequences, and 3 values are shown as circles (nodes) with their size representing their relative dominance, i.e. the number of times they were assumed to have been mentioned. Adjoining lines depicted the relations between constructs in the HVM; the thicker the line the greater the number of relations and more dominant the means-end chain. Similar procedure is used recently for example in [16], [17], [18], [19].

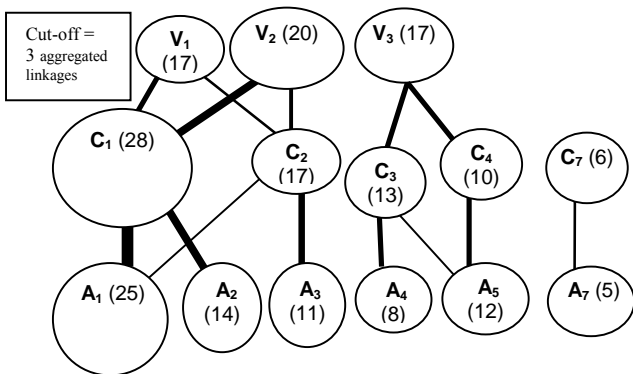

Fig. 1 Hierarchical Value Map for generated data

III. THE DEFICIENCIES OF CONVENTIONAL MEANS-END ANALYSIS

A means-end analysis is not only a revelation of nodes (meanings), but at its best shows the associations in the mind

of the individual between these nodes. In this paper HVM is considered to be an estimate of cognitive structure for respondents, as conventional means-end analyses consider HVM to be a device that allows us to see the main results of a study without having to go through all the individual ladders. As noted by [20] p. 45 not all the concepts represented on an HVM are considered by each individual subject. In fact, an individual's means-end chains only represent a subset of the concepts illustrated [20]. However, this paper suggests that the illustrated dominance of means-end chains and central elements influencing consumers' choices strongly depend on the ladders' elicitations from individual respondents, and not on the sequences of the elements emerging from the aggregated implication matrix. Hence, breaking down the ladders into aggregated chains in the HVM (see Fig. 1), may lead to an erroneous impression of the result of the means-end study.

To justify the argument following example is presented. The following example concentrates only on two attributes (A1) and (A2), one consequence (C1), and two values (V1) and (V2). Let us assume that 16 of the respondents start from (A1) and 12 of the respondents start from (A2). Let us also assume that both choices lead to consequence (C1). Furthermore, let us assume that 5 respondents starting from (A1) ends at value (V1), 3 at value (V2), and 8 stays at (C1). In addition, the respondents starting from (A2) 9 end at value (V2), 3 at value (V1), and 1 stays at (C1). Constructing an HVM (Fig. 2) from the aggregate relations, the most dominating means-end chains appear to be A1 - C1 (16) and C1 - V2 (12). Thus, HVM in Fig. 2 gives the impression that A1 produces outcome V2 most predominantly. In this particular case, the HVM in Fig. 2 obviously leads to misunderstanding the main associations and central nodes influencing consumers' choices.

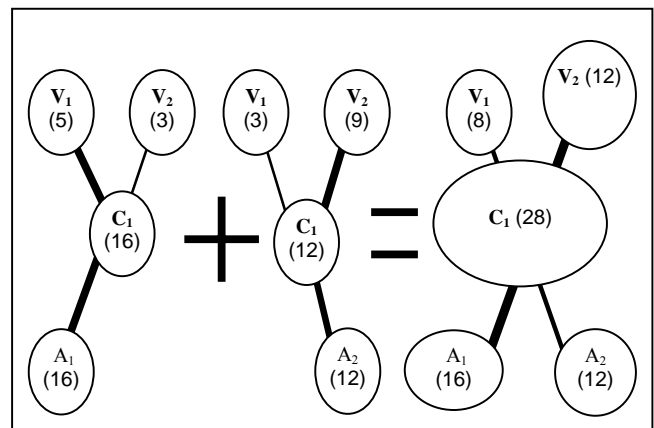

Fig. 2 Construction of conventional Hierarchical Value Map

IV. IMPROVING THE ANALYSIS OF MEANS-END DATA

Some researchers have invested in the development of more advanced methods for analyzing means-end data (e.g., [8], [2], [22], [14], [21]). Probably the most applied of these methods is the Association Pattern Technique (APT) developed by

[21]. In APT the connections between attributes and consequences and between consequences and values are investigated separately. The APT presents consumers with all possible combinations of the *a priori* defined attributes, consequences and values. The outcomes are probabilistic relations between, for instance, consequences of products and values. Hence, the matrix shows strong and weak links through estimates of the probability of a link. [21] However, APT has two things in common with the conventional procedure introduced by [12]: (1) a means-end chain data is analyzed by ignoring whether ladders are elicited from the same or different subjects, (2) an implication matrix is constructed by breaking down the ladders produced by respondents.

A means-end chain is considered to be a model of consumers' consumption-relevant cognitive structure [22]. Hence, this paper suggests that revealing the accurate product attributes related to values and defining central nodes in HVM necessitates perceiving the complete cognitive structures (ladders) elicited from respondents. Therefore an alternative procedure for analyzing means-end data is presented.

In contrast to the most of the previous methods, in present procedure the expressed ladders between attributes, consequences, and values are not broken down to construct an implications matrix. By following the presentations of [14], an HVM is constructed from the raw data of expressed ladders, intended to reveal and maintain these complete cognitive chains. While [14] used methods from graph theory to derive the Hierarchical Value Map from the raw means-end data, in present procedure the dominance of means-end chains is determined by conditional probabilities of elicited means-end chains.

The probability (see TABLE I) for each complete means-end chain is calculated by the following formula. Let us denote the nodes of the stages A, C, V by $A_i C_j D_k$. Here $j = 0$ or $k = 0$ means that the node is not visited at all. The case $i = 0$ would mean that the person has not taken part in the decision process at all. Let n_{ijk} denote the number of linkages taken from A_i to V_k via C_j . The total number of linkages thus equals $n = \sum_i \sum_j \sum_k n_{ijk}$. The number of linkages is transformed into probabilities by scaling, i.e. $p_{ijk} = n_{ijk} / n$. We are particularly interested in how the decision on the linkage from C_j to V_k depends on the starting node A_i . To examine this, the number of linkages from C_j to V_k is calculated giving $n_{+jk} = \sum_i n_{ijk}$. The conditional probability of the linkage from C_j to V_k with starting node A_i equals $p_{jk|i} = n_{ijk} / n_{+jk}$, which is calculated for each starting node A_i .

TABLE I
PROBABILITIES FOR COMPLETE MEANS-END CHAINS

Conditional probabilities for complete means-end chains (conditionally on the attributes)	Unconditional probabilities for complete means-end chains (78 complete means-end chains)
$A_1-C_1-stop = 8/25 = 32.0\%$	$A_1-C_1-stop = 8/78 = 10.3\%$
$A_1-C_1-V_1-stop = 5/25 = 20.0\%$	$A_1-C_1-V_1-stop = 5/78 = 6.4\%$
$A_2-C_1-V_2-stop = 9/14 = 64.3\%$	$A_2-C_1-V_2-stop = 9/78 = 11.5\%$
$A_3-C_2-V_1-stop = 6/11 = 54.5\%$	$A_3-C_2-V_1-stop = 6/78 = 7.7\%$
$A_4-C_3-V_3-stop = 6/8 = 75.0\%$	$A_4-C_3-V_3-stop = 6/78 = 7.7\%$
$A_5-C_4-V_3-stop = 5/12 = 41.7\%$	$A_5-C_4-V_3-stop = 5/78 = 6.4\%$

Concerning the synthetic means-end data presented in the previous section, the probabilities for each complete means-end chain are presented in Fig. 3. The cut-off level 3 was established by complete means-end chains. In light of the present study, four improvements to means-end analysis once data has been collected through laddering interviews are presented: 1) reveal and maintain the complete cognitive structures of each respondent by constructing a HVM from raw data of expressed ladders, (2) illustrate the dominance of these means-end structures in HVM by probabilities for complete cognitive structures (complete means-end chains), (3) establish the cut-off level for complete means-end chains (4) demonstrate structures and central elements in HVM by using different colours based on the colours of the attributes to identify the accurate attribute-consequence-value linkages.

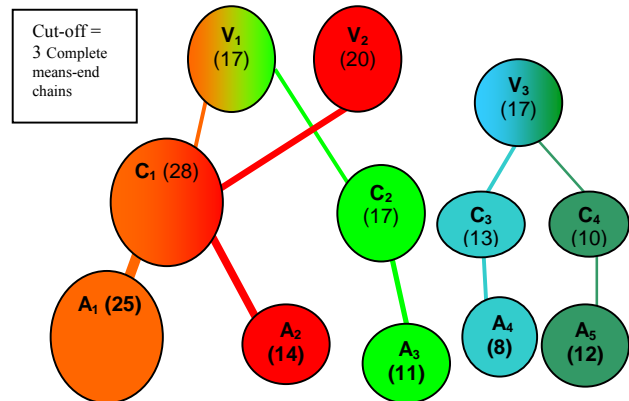

Fig. 3 Revised Hierarchical Value Map for generated data

V. CONCLUSION

The means-end approach is based on expectancy-value theory. Accordingly, the products are chosen because the individual believes that the product's attributes ultimately help him/her to achieve desired values. [5] Reference [23] theorize that in order to see consumer values influencing choices and behavior, the value must be central (of high relative importance) to a consumer and cognitively activated through encountered information or situational cues. Conventional means-end analysis is a powerful tool to elicit consumers' values. However, it fails to give an accurate impression of the

“encountered information or situational cues” (e.g. attributes) which activate a consumer’s values. Therefore, by breaking down consumers’ consumption-relevant cognitive structures, we may lose the appropriate information on how to activate these values. For example, to a group of consumers “Barbados as a holiday destination choice” may yield meaningful association English as an official language - social atmosphere - belonging. However, to other group, Barbados may yield association local culture - social atmosphere - fun & excitement. Although both attributes are linked to social atmosphere, by advertising “English as an official language” may not evoke value “fun & excitement”. On the other hand by advertising “English as an official language” may be effective in evoking value “belonging”.

This paper has attempted to improve the analysis of means-end chain data and the graphic presentation of results of means-end study by developing a new conceptual procedure to determine the dominant means-end chains and central nodes, and to construct an HVM. Compared to conventional methods, the present approach takes into account the complete cognitive structures of each respondent to understand the dominant consumption-relevant cognitive structures of the aggregate of respondents. Reference [21] has established that in laddering data, attributes and values are conditionally independent, given the consequences. Although, this implies that it is not necessary to record the full links and that one can work with an aggregate implication matrix, it would be interesting to see if this holds for a broad range of products and situations. Owing to the exploratory nature of the current study, the present method was introduced by using very simplified synthetic data. In order to elaborate and validate the method, empirical research is needed. However, the current paper provides theoretical building blocks for development of more advanced methods to generate consumer insights by understanding how consumers value attributes of products or services.

REFERENCES

- [1] Reynolds, T. J., Gengler, C.E., Howard, D. (1995). A Means-End Analysis of Brand Persuasion through Advertising. *International Journal of Research in Marketing* 12 3, 257–266.
- [2] Botschen, G., Thelen, E. (1998). Hard versus soft laddering: Implications for appropriate use. In I. Balderjahn, C. Mennicke, & E. Vernet (Eds.), *New developments and approaches in consumer behaviour research* (pp. 321-339). Stuttgart: Poeschel
- [3] Christensen, G.L., Olson, J.C. (2002). Mapping consumers’ mental models with ZMET. *Psychology & Marketing* 19, 477–502.
- [4] Vriens, M., ter Hofstede, F. (2000). Linking attributes, benefits and consumer values. *Journal of Marketing Research* 12 (3), 4–10.
- [5] Gutman J. (1997). Means-end chains as goal hierarchies. *Psychology and Marketing* 14 (6), 545–560.
- [6] Grunert, K.G., Grunert, S.C. (1995). Measuring Subjective Meaning Structures by the Laddering Method: Theoretical Considerations and Methodological Problems. *International Journal of Research in Marketing* 12, 209–225.
- [7] Gutman, J. (1982). A Means-End Chain Model Based on Consumer Categorization Processes. *Journal of Marketing* 46, 60–72.
- [8] Aurifeille, J-M., Valette-Florence, P. (1995) Determination of the dominant means-end chains: A constrained clustering approach. *International Journal of Research in Marketing* Volume 12 (3), 267–278.
- [9] Gengler, C.E., Klenosky, D.B., Mulvey M.S. (1995). Improving the graphic representation of means-end results. *International Journal of Research in Marketing* 12 (3), 245–256.
- [10] van Rekom, J., Wierenga, B. (2007). On the hierarchical nature of means-end relationships in laddering data. *Journal of Business Research* 60, 401–410.
- [11] Grunert, K.G., Bech-Larsen, T. (2005) Explaining choice option attractiveness by beliefs elicited by the laddering method. *Journal of Economic Psychology* 26, 223–241.
- [12] Reynolds, T.J., Gutman, J. (1988). Laddering theory, method, analyses and interpretation. *Journal of Advertising Research* 28 (1), 11–31.
- [13] Brunso, K., Scholderer, J., Grunert, K.G. (2004). Closing the gap between values and behavior – a means-end theory of lifestyle. *Journal of Business Research* 57, 665-670.
- [14] Valette-Florence, P., Rapacchi B. (1991). Improvements in means-end chain analysis using graph theory and correspondence analysis. *Journal of Advertising Research* 31 (1), 30–45.
- [15] Olson J., Reynolds T. (1983). Understanding Consumer’s cognitive structures: Implications for advertising strategy, in Percy L., Woodside A. (eds.), *Advertising and Consumer psychology*, Lexington Books, Lexington, MA.
- [16] Devlin, D, Birtwistle, G, Macedo N. (2003). Food retail positioning strategy: a means-end chain analysis. *British Food Journal* 105 (9), 653–670
- [17] Søndergaard, H.A., Harmsen H. (2007). Using market information in product development. *Journal of Consumer Marketing* 24 (4), 194–201.
- [18] Wagner, T. (2007) Shopping motivation revised: a means-end chain analytical perspective. *International Journal of Retail & Distribution Management* 35 (7), 569–582.
- [19] Boecker, A., Hartl, J., Nocella, G. (2008). How different are GM food accepters and rejecters really? A means-end chains application to yogurt in Germany. *Food Quality and Preference* 19 (4), 383–394.
- [20] Reynolds, T.J., Craddock, A.B. (1988). The application of the MECCAS model to the development and assessment of advertising strategy: A case study. *Journal of Advertising Research* 28 (2), 43–54.
- [21] ter Hofstede, F., Audenaert, A., Steenkamp, J.E.M., Wedel, M. (1998). An investigation into the association pattern technique as a quantitative approach to measuring means-end chains. *International Journal of Research in Marketing* 15, 37–50.
- [22] Grunert, K.G., Beckmann, S.C., Sørensen, E. (2001) “Means-end chains and laddering: An inventory of problems and an agenda for research”. In: *Understanding Consumer Decision-making: The Means-end Approach to Marketing and Advertising Strategy*, pp. 63–90, T. C. Reynolds & J. C. Olson (Eds.).
- [23] Verplanken, B., Holland, R.W. (2002). Motivated decision making: Effects of activation and self-centrality of values on choices and behavior. *Journal of Personality and Social Psychology* 82, 434–447.