

Characteristics Analysis of Voltage Sag and Voltage Swell in Multi-Grounded Four-Wire Power Distribution Systems

Jamal Moshtagh, and Hassan Pourvali Souraki

Abstract—In North America, Most power distribution systems employ a four-wire multi-grounded neutral (MGN) design. This paper has explained the inherent characteristics of multi-grounded three-phase four-wire distribution systems under unbalanced situations. As a result, the mechanism of voltage swell and voltage sag in MGN feeders becomes difficult to understand. The simulation tool that has been used in this paper is MATLAB under Windows software. In this paper the equivalent model of a full-scale multi-grounded distribution system implemented by MATLAB is introduced. The results are expected to help utility engineers to understand the impact of MGN on distribution system operations.

Keywords—Distribution systems, multi-grounded, neutral, three-phase four-wire, ground.

I. INTRODUCTION

A MULTI-GROUNDED three-phase four-wire service is widely adopted in modern power distribution systems due to having lower installation costs and higher sensitivity of fault protection than three-phase three-wire service [1]. The return current is due to both the unbalanced load and the nonlinear characteristics of electrical equipment through the distribution feeder. The return current may be larger than the phase currents if three-phase loads are too much unbalanced in some segments. The neutrals play an important role in power quality and safety problems [2]-[3].

The different technical solutions that considered the neutral in medium voltage are: systems without neutral (Brazil), systems with an isolated neutral (Italy, Finland, and Switzerland), systems with multiple grounding of the neutral and connecting the utility neutral with customer grounding (USA, Greece), systems with solid neutral grounding (U.K.), systems with resistance neutral grounding (France, U.K.), systems with reactance neutral grounding (Belgium, Spain, Portugal, Netherlands), and systems compensated via a “Petersen” coil (Germany), to name a few [4]. Therefore, it is essential for power engineers to realize the inherent

characteristics of this kind of power systems while doing system planning and operation. However, recently power engineers ordinarily used three-phase power-flow programs to analyzing an unbalanced power distribution system. The commercial simulation software, MATLAB under Windows, was adopted in this paper. The MATLAB has powerful simulation ability and a friendly graphical interface. This software is commonly used for electronic circuit simulations, but it also can be used in power system analyzing to analyze steady-state and transient problems. The MATLAB is capable of representing and simulating a power distribution system using suitable equivalent models of system components. The MGN configuration is able to protect all ground short-circuit faults easily. Power engineers often find out that it is difficult to analyze the MGN configuration due to the presence of a fourth conductor and its multi-grounded topology. The symmetrical components-based methods are not applicable to such cases, thus there are some different opinions about the effects of MGN. Substation GPR as higher fault current could flow through the substation. The transient overvoltage (i.e., voltage swell) and under voltage (i.e., voltage sag) may be increased and decrease respectively due to rising the fault current. The proposed analysis shows that there are several factors, such as the loop current in the neutral wire and the neutral-to-phase voltage induction that affect the voltage sag and voltage swell. Some of them produce opposite effects. The net effect is that the transient overvoltage and substation GPR are reduced and transient under-voltage increased. In this paper the current flow pattern and transient voltage components are illustrated, also multiphase load flow program is used to assist this analysis and explore the inherent characteristics of multi-grounded three-phase four-wire distribution systems under unbalanced situations [5].

II. DESIGN AND CONSTRUCTION

A distribution power system model is built with SimPowerSystems toolbox in MATLAB/Simulink. The parameters of transformers, lines and etc in model are obtained in practical system. The procedure for constructing an equivalent model is as follows:

- 1) Obtaining the equivalent model of each major system component
- 2) Setting the necessary parameters of all system

Jamal Moshtagh has obtained his PH. D degree in power engineering. He is now with the Department of Engineering, University of Kurdistan, Sanandaj, Iran (e-mail: Moshtagh79@yahoo.com).

Hassan Pourvali Souraki is a M.S. candidate in power engineering, University of Kurdistan, Sanandaj, Iran (e-mail: hassan.Pourvali@gmail.com).

components

3) Forming a full-scale system equivalent model by combining the suitable component models in accordance with the system structure.

In this paper, the coupling-free equivalent circuits of system components are used to model a power distribution system. These coupling-free equivalent circuits are suitably applied in MATLAB because they are represented with simple elements such as resistance, inductance, capacitance, voltage and/or current source. The coupling-free equivalent circuits of major system components such as co-generators, transformers, conductors and loads have been developed successfully.

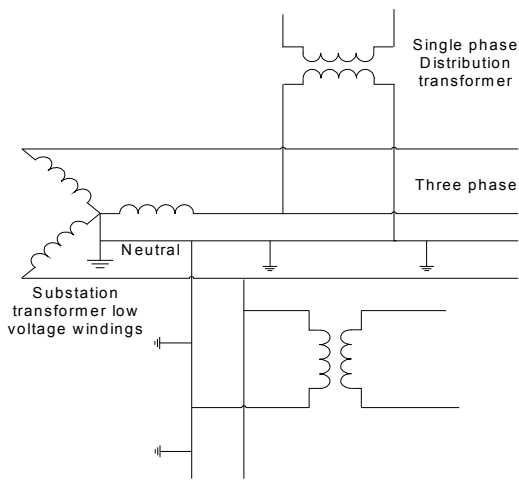

Fig. 1 Equivalent model of a multi-grounded four-wire distribution system by MATLAB

The proposed method is flexible as, Users can modify the coupling-free equivalent networks within a reasonable range and then implement these equivalent circuits by MATLAB. It is very important to set necessary parameters of system components. Unsuitable parameter settings may make incorrect simulation results, and also the convergence of program may be faced with difficulty. At first, the equivalent models of system components are obtained and the necessary parameters of system components are set, then a full-scale system equivalent model can be formed by combining these suitable component models in accordance with the system structure. In the case of multi-grounded three-phase four-wire distribution system, users must pay their attention to the neutral grounding, as the neutral wires are multi-grounded, then phase wires and neutrals have to be divided into shorter segments according to the number and location of grounds. Thus the neutral grounding can be represented explicitly.

With following the model of procedure, a system equivalent model can be constructed quickly and simulated by MATLAB. The MATLAB/Simulink model is shown in Fig. 1. Each block, represents the equivalent circuit model of a system component. The high voltage side of the distribution substation is simplified as an ideal three-phase source. It is worthy to note

that neutral wires and grounding are represented explicitly. The neutral can be grounded with a resistance, inductance or capacitance. The simulations make focus on the performances of substation GPR, voltage sags and voltage swell of the customer side during the faults.

III. CURRENT FLOW PATTERN DURING A GROUND FAULT

The power distribution system that is depicted in Fig. 2 is utilized for analysis. The main feeder is fed by a 69–11.4 kV, 25 MVA power transformer sited in the distribution substation. The primary feeders and laterals are all overhead construction. Their parameters are shown in Table I. The common point of the secondary side of the substation transformer with wye connection and the neutral wire are solidly grounded. The grounding resistance of the neutral point of the substation transformer and the grounding points along the neutral wire are assumed to be 0.7 and 5, respectively [5]. The dots represent the distribution transformers and their loads. There are 16 distribution transformers in the propose system to serve the customers that are distributed along the feeders [7]. It is assumed that all the distribution transformers are operated in full-load condition with 0.8 lagging power factor, their ratings and connection phases are listed in Table II. Table II indicates that single-phase and open wye-open delta connections are used largely in this proposed system. Hence, the system is usually operated under unbalanced conditions [5].

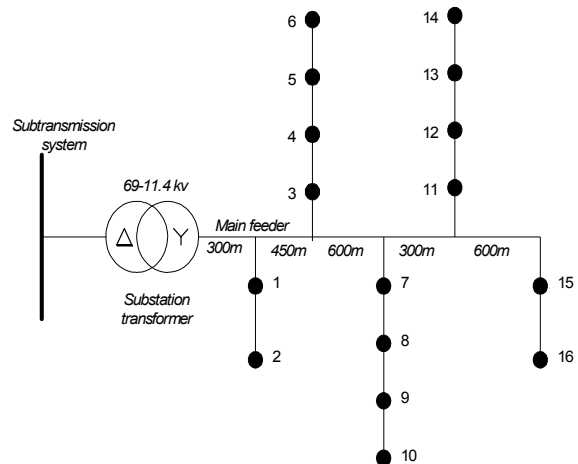

Fig. 2 A single-line diagram of the proposed system

TABLE I
PARAMETERS OF CONDUCTORS IN THE PROPOSED SYSTEM

Conductor impedance	feeder		lateral	
	phase	neutral	phase	neutral
Resistance (Ω/km)	0.131	0.209	0.945	0.945
Reactance (Ω/km)	0.364	0.382	0.355	0.355

TABLE II
RATINGS AND CONNECTION PHASES OF DISTRIBUTION TRANSFORMERS IN THE PROPOSED SYSTEM

NO	Windings Connection	phase	Secondary Voltage(V)	Capacity (KVA)	Impedance (Z%)
1	Delta-Gnd. Wye	A,B,C	220	500	1.89
2	Single-phase	B	110	50	1.75
3	Single-phase	B	220/110	50	1.75
4	Single-phase	B	220/110	50	1.75
5	Delta-Gnd. Wye	A,B,C	220	500	1.89
6	Delta-Gnd. Wye	A,B,C	220	500	1.89
7	Open Wye	B,C	220	100,100	1.70,1.70
8	Open Wye	A,C	220/110	167,100	1.89,1.70
9	Single-phase	C	220/110	100	1.70
10	Single-phase	C	220/110	100	1.70
11	Delta-Delta	A,B,C	220	500	1.89
12	Open Wye	A,C	220	100,100	1.70,1.70
13	Single-phase	C	110	50	1.75
14	Single-phase	B	220	50	1.75
15	Open Wye	A,B	220/110	167,100	1.89,1.70
16	Single-phase	C	220/110	50	1.75

Fig. 3 illustrates the detailed ground connections of single-phase and open wye distribution transformers in a multi-grounded distribution system. In order to save cost and work days, the common ground scheme is popularly adopted in this kind of distribution system [6].

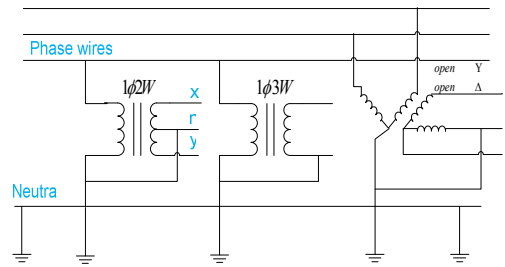

Fig. 3 Grounding connections of single-phase and open wye transformers in a multi-grounded distribution system

For such a system, the current flowing back to the substation neutral, I_N , consists of three components:

- I_g represents the return current through the substation ground
- I_{split} represents the current split by the neutral grounding resistances.

There are some resistance (as current divider) that splits the substation neutral current between the substation grounding resistance and neutral grounding resistances;

- $I_{induced}$ contains the current that is produced by the fault-current-induced voltage on the neutral.

This current is shown in Fig. 5 where the voltage sources represent the voltages induced by the fault current on the neutral conductor. It is obvious that, the current, $I_{induced}$, has an opposite direction to I_N , which further reduces. As a result of the currents $I_{induced}$ and I_{split} , the substation ground current I_g is actually less than the substation neutral current I_N . The increase of fault current does not necessarily lead to an increase of I_g . Since the ground potential rise in the substation is equal to $R_g \cdot I_g$, the GPR does not increase necessarily. From Fig. 4, the voltages of the unfaulted phases such as V_b can be determined by equation (1)

$$V_b = V_N + E_b + V_{induced-a} + V_{induced-n} \tag{1}$$

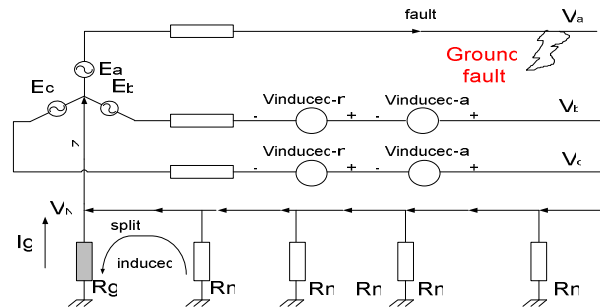

Fig. 4 MGN configuration under one-phase to ground fault

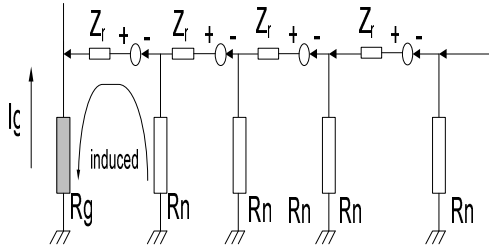

Fig. 5 Loop current of neutral due to voltage induction.

IV. CASE STUDY RESULTS

In this paper two cases are used to demonstrate the effects of the different factors. The first case is the MGN configuration for a 11 kV line. The second case has no neutral. This configuration is commonly called three-wire earth return (TWER) case. Fig. 4 shows the three components of the substation ground current, I_g . It can be seen from Table III that the MGN case does increase the I_N in comparison with the TWER case. However, the two current components, $I_{induced}$ and I_{split} have an opposite direction to the I_N . Consequently the current that actually flows into the substation is less than the case of the TWER. The substation GPR is also reduced accordingly. Fig. 6 depicts the relative impacts of three factors as a function of fault location. The current of the I_N can be determined with following equation (2)

$$I_N = I_g + I_{split} - I_{induced} \tag{2}$$

TABLE III
COMPONENTS OF SUBSTATION GROUND CURRENT

currents	TWER(A)	MGN
I_N	1505	1702
$I_{split}+I_{induced}$	0	- 667
Total(= I_g)	1505	1035

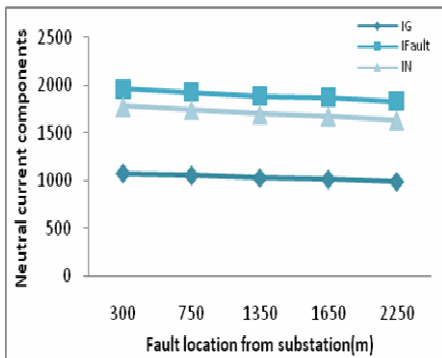

Fig.6 Substation ground current component.

The results of voltage swell are shown in Table III for MGN and in Table IV for TWER and The results of voltage sags are shown in Table V for MGN and in Table VI for TWER. The values presented are projected in the direction of the corresponding phase voltages at the sending point. It clearly evident that the fault-current-induced voltage contributes the voltage swell and voltage sags importantly. The net effect is that the both (V_a) and (V_b, V_c) of the MGN case are less than those of the TWER case. Similarly the neutral voltage V_N can either support or oppose the voltage swell and voltage sag depending on the concerned phase of the line [7]. The objective in grounding a neutral wire in a distribution system is to stabilize system voltages and provide the return path for grounded-fault current [9]. Multi-grounded neutral wires can heighten system ground reliability effectively. Direct grounding is commonly used in distribution systems for saving costs and work days [8]-[10].

TABLE IV
VOLTAGES SWELL IN PHASE B AND C (MGN)

Voltages phase (max)	B(Volt)	C(Volt)
V phase	9255	9252
V phase fault	10250	10200
$\Delta V_{phase(swell)}$	288	35
V phase(swell)-(pu)	1.108	1.102

TABLE V
VOLTAGE SWELLS IN PHASE B AND C (TWER)

Voltages phase (max)	B(Volt)	C(Volt)
V phase	9250	9250
V phase fault	10780	12700
$\Delta V_{phase(swell)}$	1530	3446
V phase(swell)-(pu)	1.16	1.37

TABLE VI
VOLTAGE SAG IN PHASE A (MGN)

Voltages phase (max)	A(Volt)
V phase	9250
V phase fault	6150
$\Delta V_{phase(sag)}$	-390
V phase(swell)-(pu)	0.664

TABLE VII
VOLTAGE SAG IN PHASE A (TWER)

Voltages phase (max)	A(Volt)
V phase	9250
V phase fault	4553
ΔV phase(sag)	-1140
V phase(swell)-(pu)	0.49

V. CONCLUSION

This paper has revealed the factors contributing to the substation GPR and feeder voltage swell and voltage sag in a multi-ground distribution system. Neutrals and grounding play an important role in a power system. Multiple ground neutral wire is adopted widely in modern distribution systems. This application could benefit to system operation, but it also complicates the characteristics of the distribution system. The relative impact of each factor is illustrated. The results show that the neutral-induced and split currents are helpful for reducing the substation GPR, in spite of higher fault current experienced by the system. The net effect is that the amount of voltage swell is reduced in the MGN case in comparison with the TWER case and voltage sag is increase in the MGN case compared to the TWER scheme.

REFERENCES

- [1] J. J. Burke, *Power Distribution Engineering—Fundamentals and Applications*. New York: Marcel Dekker, 1994, pp. 16–17.
- [2] T. H. Chen, M. S. Chen, T. Inoue, P. Kotas, and E. A. Chebli, “Three-phase cogenerator and transformer models for rigorous distribution system analysis,” *IEEE Trans. Power Delivery*, vol. 6, no. 4, pp. 1671–1681, Oct. 1991.
- [3] T. H. Chen, J. D. Chang, and Y. L. Chang, “Models of grounded mid-tap open wye and open delta connected transformers for rigorous analysis of a distribution system,” *IEEE Proceedings—Generation, Transmission and Distribution*, vol. 143, no. 1, pp. 82–88, Jan. 1996.
- [4] A. P. Meliopoulos, J. Kennedy, C. A. Nucci, A. Borghetti, and G. Contaxies, “Power distribution practices in USA and Europe: impact on power quality,” in *Proc. Int. Conf. Harmon. Quality Power*, vol. 1, 1998, pp. 24–29.
- [5] IEEE Recommended Practice for Grounding of Industrial and Commercial Power Systems, *IEEE Std. 142-1991*, June 1992.
- [6] T. H. Chen, W. C. Yang, T. Y. Guo, and G. C. Pu, “Modeling and analysis of asymmetrical three-phase distribution transformer banks with mid-tap connected to the secondary neutral conductor,” *Electric Power Systems Research*, vol. 54, no. 2, pp. 83–89, May 2000.
- [7] J. C. Balda, A. R. Oliva, D. W. McNabb, and R. D. Richardson, “Measurements of neutral currents and voltages on a distribution feeder,” *IEEE Trans. Power Delivery*, vol. 12, no. 4, pp. 1799–1804, Oct. 1997.
- [8] A. P. S. Meliopoulos, J. Kennedy, C. A. Nucci, A. Borghetti, and G. Contaxies, “Power distribution practices in USA and Europe: Impact on power quality,” in *Proc. 1998 International Conference on Harmonics and Quality of Power*, vol. 1, pp 24–29.
- [9] J. C. Das and R. H. Osman, “Grounding of AC and DC low-voltage and medium-voltage drive system,” *IEEE Trans. Industry Applications*, vol. 34, no. 1, pp. 205–216, Jan./Feb. 1998.
- [10] Jim Burke and Mike Marshall, “Distribution System Neutral Grounding,” ABB Power T&D – Raleigh, North Carolina, 0-7803-7285-9/01/\$17.00 (C) 2001IEEE.