

On the Exact Solution of Non-Uniform Torsion for Beams with Asymmetric Cross-Section

A. Campanile, M. Mandarino, V. Piscopo

Abstract—This paper deals with the problem of non-uniform torsion in thin-walled elastic beams with asymmetric cross-section, removing the basic concept of a fixed center of twist, necessary in the Vlasov's and Bencoter's theories to obtain a warping stress field equivalent to zero. In this new torsion/flexure theory, despite of the classical ones, the warping function will punctually satisfy the first indefinite equilibrium equation along the beam axis and it won't be necessary to introduce the classical congruence condition, to take into account the effect of the beam restraints. The solution, based on the Fourier development of the displacement field, is obtained assuming that the applied external torque is constant along the beam axis and on both beam ends the unit twist angle and the warping axial displacement functions are totally restrained.

Finally, in order to verify the feasibility of the proposed method and to compare it with the classical theories, two applications are carried out. The first one, relative to an open profile, is necessary to test the numerical method adopted to find the solution; the second one, instead, is relative to a simplified containership section, considered as full restrained in correspondence of two adjacent transverse bulkheads.

Keywords—Non-uniform torsion, Asymmetric cross-section, Fourier series, Helmholtz equation, FE method.

I. INTRODUCTION

It's well known that the classical Saint Venant's theory is based on the uncoupling and superposition of four basic responses: stretching; major-axis bending, coupled with major shear; minor-axis bending, coupled with minor shear and pure torsion.

Anyway, when the beam is subjected to a varying torque or the axial warping displacements are partially or totally restrained at one or both member ends, the torsion becomes non-uniform, the twist rate varies along the beam and the displaced centroids describe a curve. In this case two great problems arise: first of all, it is not possible to uncouple a pure torque loading from the bending one caused by the curvature of the centroidal axis; then, the centre of twist is not constant along the beam axis.

So, in the following, the traditional concept of a fixed centre of twist is abandoned and a more general theory is developed.

A. Campanile is Full Professor at the University of Naples "Federico II", Department of Naval Architecture and Marine Engineering, Via Claudio 21 80125 Napoli Italy (phone: +39-081-7683710; fax: +39-081-2390380; e-mail: campanil@unina.it).

M. Mandarino is Full Professor at the University of Naples "Federico II", Department of Naval Architecture and Marine Engineering, Via Claudio 21 80125 Napoli Italy (phone: +39-081-7683701; fax: +39-081-2390380; e-mail: mandarin@unina.it).

V. Piscopo is a third year Ph.D. student at the University of Naples "Federico II", Department of Naval Architecture and Marine Engineering, Via Claudio 21 80125 Napoli Italy (fax: +39-081-2390380; e-mail: vincenzo.piscopo@unina.it).

Furthermore, despite of the classical theories, the warping function will fully respect the first indefinite equilibrium equation and the displacement field, decomposed by means of Fourier series, will implicitly respect also the beam ends boundary conditions.

II. THEORY DEVELOPMENT

Let us assume that the beam cross-section rotates undeformed through a small angle $\vartheta_t(x)$ about the centroidal axis x , warps out of its plane and is subjected to rigid body motions along the section principal axes of inertia. Let us define the global Cartesian frames sketched in Fig. 1, with origin O in correspondence of the left beam end, x axis defined along the beam length and passing through the section centroid and η, ζ axes defined in the section plane and coinciding with the section principal axes of inertia.

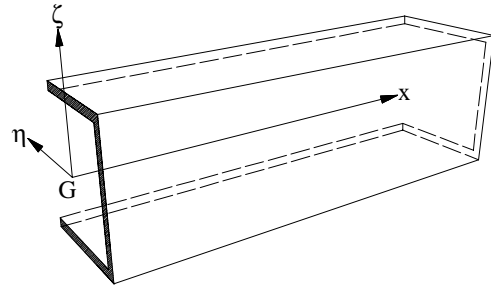

Fig. 1 Reference Coordinate system

In this hypothesis, denoting by u, v, w the three displacement components in the x, η, ζ directions respectively, the displacement field can be assumed as follows:

$$\begin{cases} u = \tilde{u}(x, \eta, \zeta) - \eta \frac{dv_0}{dx} - \zeta \frac{dw_0}{dx} \\ v = v_0(x) - \vartheta_t(x)\zeta \\ w = w_0(x) + \vartheta_t(x)\eta \end{cases} \quad (1)$$

where $\tilde{u}(x, \eta, \zeta)$ is the axial displacement function, $\vartheta_t(x)$ is the rotation of the section about the x -axis, positive if counter-clockwise, $v_0(x)$ and $w_0(x)$ are the centroid lateral rigid body motions along the η and ζ axes, respectively.

With the previous assumptions and notations, the strain components (for small deformation) are then given by:

$$\begin{cases} \varepsilon_x = \frac{\partial \tilde{u}}{\partial x} - \eta \frac{d^2 v_0}{dx^2} - \zeta \frac{d^2 w_0}{dx^2} \\ \varepsilon_y = 0 \\ \varepsilon_z = 0 \end{cases} \quad (2.1)$$

$$\begin{cases} \gamma_{xy} = \frac{\partial \tilde{u}}{\partial \eta} - \vartheta_1 \zeta \\ \gamma_{xz} = \frac{\partial \tilde{u}}{\partial \zeta} + \vartheta_1 \eta \\ \gamma_{yz} = 0 \end{cases} \quad (2.2)$$

having defined the unit twist angle as follows:

$$\vartheta_1 = \frac{d\vartheta_t}{dx} \quad (2.3)$$

Denoting by E the Young modulus, G the Coulomb modulus and ν the Poisson modulus, the Navier equations can be so specialized:

$$\begin{cases} \sigma_x = E \left[\frac{\partial \tilde{u}}{\partial x} - \eta \frac{d^2 v_0}{dx^2} - \zeta \frac{d^2 w_0}{dx^2} \right] \\ \tau_{xy} = G \left[\frac{\partial \tilde{u}}{\partial \eta} - \zeta \vartheta_1 \right] \\ \tau_{xz} = G \left[\frac{\partial \tilde{u}}{\partial \zeta} + \eta \vartheta_1 \right] \end{cases} \quad (3)$$

As regards the (3)₁ expression, it derives by assuming as anelastic tensions σ_y in the web, σ_z in the flanges, what allows to reduce the (3)₁ coefficient to the ratio $\frac{E}{1-\nu^2} \cong E$.

As regards the indefinite equilibrium equations, which naturally involve all the stress components, they can be rewritten neglecting the body forces and the pressure loads. The system of the indefinite and boundary equilibrium equations becomes:

$$\begin{cases} \text{div } \Sigma = 0 \\ \Sigma \mathbf{n} = 0 \end{cases} \quad (4)$$

where Σ is the stress tensor and \mathbf{n} is the unit vector normal to the section boundary (positive outwards). Concerning the indefinite equilibrium equations, it is not necessary to satisfy punctually the ones in the transverse directions, as the only relevant scalar equations, in the thin-walled beam theory, are the x -projections of the vectorial (4). In the further hypothesis of cylindrical body, assuming $\mathbf{n} \cdot \mathbf{i} = 0$, the equilibrium conditions inside the body and on the boundary can be so rewritten:

$$\begin{cases} \frac{\partial \tau_{xy}}{\partial \eta} + \frac{\partial \tau_{xz}}{\partial \zeta} = -\frac{\partial \sigma_x}{\partial x} \quad \forall P \in \overset{\circ}{A} \\ \tau_{xn} = 0 \quad \forall P \in Fr(A) \end{cases} \quad (5)$$

having denoted by A the cross-section domain and by τ_{xn} the tangential stress component, normal to the boundary. In terms of displacements the problem (5) becomes:

$$\begin{cases} \frac{\partial^2 \tilde{u}}{\partial \eta^2} + \frac{\partial^2 \tilde{u}}{\partial \zeta^2} = -2(1+\nu) \left[\frac{\partial^2 \tilde{u}}{\partial x^2} - \eta \frac{d^3 v_0}{dx^3} - \zeta \frac{d^3 w_0}{dx^3} \right] \quad \forall P \in \overset{\circ}{A} \\ \frac{\partial \tilde{u}}{\partial n} = -\vartheta_1 (\eta \alpha_{nz} - \zeta \alpha_{ny}) \quad \forall P \in Fr(A) \end{cases} \quad (6)$$

having denoted by α_{ny} and α_{nz} the director cosines of the unit normal vector, positive if outwards.

The axial stress field, equivalent to zero, must also verify the following global conditions:

$$\begin{cases} \int_A \sigma_x dA = 0 \\ \int_A \sigma_x \eta dA = 0 \\ \int_A \sigma_x \zeta dA = 0 \end{cases} \quad (7)$$

The tangential stress field, instead, is related to the twist moment sectional force by the equation:

$$M_t(x) = \int_A [\tau_{xz} \eta - \tau_{xy} \zeta] dA \quad (8)$$

finally becoming:

$$M_t(x) = G I_p \vartheta_1 + G \int_A \left[\frac{\partial \tilde{u}}{\partial \zeta} \eta - \frac{\partial \tilde{u}}{\partial \eta} \zeta \right] dA \quad (9)$$

thanks to the following position:

$$I_p = \int_A [\eta^2 + \zeta^2] dA = I_\zeta + I_\eta \quad (10)$$

Concerning the support end conditions, denoting by L the beam length, let us suppose that the beam is "warping clamped" at both ends – by moving constraints with 3 degrees of freedom: the two lateral displacements and the torsional rotation, as for the bulkheads constraints of a hull module – so obtaining:

$$u(0, \eta, \zeta) = u(L, \eta, \zeta) = 0 ; \quad \vartheta_1(0) = \vartheta_1(L) = 0 \quad (11.1)$$

$$\frac{dv_0}{dx}(0) = \frac{dv_0}{dx}(L) = 0 ; \quad \frac{dw_0}{dx}(0) = \frac{dw_0}{dx}(L) = 0 \quad (11.2)$$

from which it results:

$$\tilde{u}(0, \eta, \zeta) = \tilde{u}(L, \eta, \zeta) = 0 \quad (11.3)$$

In order to solve the problem, it is possible to preliminarily expand the axial displacement function, the unit twist angle and the two rigid body motion functions into appropriate trigonometric series, verifying the conditions (11) and reduced to their M-partial sums, as follows:

$$\begin{cases} \tilde{u}(x, \eta, \zeta) = \sum_{m=1}^M W_m(\eta, \zeta) \sin \frac{m\pi x}{L} \\ \vartheta(x) = \sum_{m=1}^M \Omega_m \sin \frac{m\pi x}{L} \end{cases} \quad (12)$$

$$\begin{cases} v_0(x) = \sum_{m=1}^M B_m \cos \frac{m\pi x}{L} \\ w_0(x) = \sum_{m=1}^M C_m \cos \frac{m\pi x}{L} \end{cases} \quad (13)$$

The eq. (11) are implicitly satisfied $\forall m=1..M$. The indefinite and boundary equations (6), thanks to the orthogonality of the trigonometric functions, become:

$$\begin{cases} \nabla^2 W_m = 2(1+\nu) \frac{m^2 \pi^2}{L^2} W_m + 2(1+\nu) \frac{m^3 \pi^3}{L^3} [\eta B_m + \zeta C_m] \\ \frac{\partial W_m}{\partial n} = \Omega_m (\zeta \alpha_{ny} - \eta \alpha_{nz}) \end{cases} \quad (14)$$

Expressing the unknown m -th term $W_m(\eta, \zeta)$ in the form:

$$W_m(\eta, \zeta) = \alpha_m(\eta, \zeta) \Omega_m + \beta_m(\eta, \zeta) B_m + \gamma_m(\eta, \zeta) C_m \quad (15)$$

the problem (14) can be decomposed into three Neumann boundary problems associated to the Helmholtz equation:

$$\begin{cases} \nabla^2 \alpha_m = 2(1+\nu) \frac{m^2 \pi^2}{L^2} \alpha_m \\ \frac{\partial \alpha_m}{\partial n} = \zeta \alpha_{ny} - \eta \alpha_{nz} \end{cases} \quad (16.1)$$

$$\begin{cases} \nabla^2 \beta_m = 2(1+\nu) \frac{m^2 \pi^2}{L^2} \beta_m + 2(1+\nu) \frac{m^3 \pi^3}{L^3} \eta \\ \frac{\partial \beta_m}{\partial n} = 0 \end{cases} \quad (16.2)$$

$$\begin{cases} \nabla^2 \gamma_m = 2(1+\nu) \frac{m^2 \pi^2}{L^2} \gamma_m + 2(1+\nu) \frac{m^3 \pi^3}{L^3} \zeta \\ \frac{\partial \gamma_m}{\partial n} = 0 \end{cases} \quad (16.3)$$

The first of (7) implies that the three unknown functions $\alpha_m(\eta, \zeta)$, $\beta_m(\eta, \zeta)$ and $\gamma_m(\eta, \zeta)$ must also respect the following global conditions:

$$\begin{cases} \int_A \alpha_m dA = 0 \\ \int_A \beta_m dA = 0 \\ \int_A \gamma_m dA = 0 \end{cases} \quad (17)$$

Concerning the unknown amplitudes Ω_m, B_m, C_m , these ones can be determined thanks to the second and third of (7) and the eq. (9), obtaining the equation system:

$$[S] \cdot \begin{bmatrix} \Omega_m \\ B_m \\ C_m \end{bmatrix} = \begin{bmatrix} \frac{2}{GL} \int_0^L M_t \sin \frac{m\pi x}{L} dx \\ 0 \\ 0 \end{bmatrix} \quad (18)$$

specialized as follows, if it's assumed $M_t(x) = M_t = const.:$

$$[S] \cdot \begin{bmatrix} \Omega_m \\ B_m \\ C_m \end{bmatrix} = \begin{bmatrix} \frac{2M_t}{G} \frac{1 - \cos m\pi}{m\pi} \\ 0 \\ 0 \end{bmatrix} \quad (19)$$

The matrix $[S]$ is the following:

$$[S] = \begin{bmatrix} \alpha_{m1} + I_p & \beta_{m1} & \gamma_{m1} \\ \alpha_{m2} & \beta_{m2} - \frac{m\pi}{L} I_\zeta & \gamma_{m2} - \frac{m\pi}{L} I_{\eta\zeta} \\ \alpha_{m3} & \beta_{m3} - \frac{m\pi}{L} I_{\eta\zeta} & \gamma_{m3} - \frac{m\pi}{L} I_\eta \end{bmatrix} \quad (20)$$

with $I_{\eta\zeta}$ section product of inertia and $\alpha_{m1}, \alpha_{m2}, \alpha_{m3}$ coefficients so defined (similarly for β_m and γ_m):

$$\begin{cases} \alpha_{m1} = \int_A \left[\eta \frac{\partial \alpha_m}{\partial \zeta} - \zeta \frac{\partial \alpha_m}{\partial \eta} \right] dA \\ \alpha_{m2} = - \int_A \eta \alpha_m dA \\ \alpha_{m3} = - \int_A \zeta \alpha_m dA \end{cases} \quad (21)$$

Introducing the following function $F_m(\eta, \zeta)$:

$$F_m(\eta, \zeta) = \alpha_m \Omega_m + \left(\beta_m + \eta \frac{m\pi}{L} \right) B_m + \left(\gamma_m + \zeta \frac{m\pi}{L} \right) C_m \quad (22)$$

it is possible to define the bimoment as follows:

$$B = \sum_{m=1}^M \int_A \sigma_{x-m} \cdot \frac{F_m(\eta, \zeta)}{\Omega_m} dA \quad (23)$$

Finally, the eq. (23) becomes:

$$B = \frac{E}{L} \sum_{m=1}^M \frac{m\pi}{\Omega_m} \cos \frac{m\pi x}{L} \int_A F_m^2(\eta, \zeta) dA \quad (24)$$

while the stress field is the following one:

$$\begin{cases} \sigma_x = E \sum_{m=1}^M F_m(\eta, \zeta) \frac{m\pi}{L} \cos \frac{m\pi x}{L} \\ \tau_{xy} = G \sum_{m=1}^M \left[\left(\frac{\partial \alpha_m}{\partial \eta} - \zeta \right) \Omega_m + \frac{\partial \beta_m}{\partial \eta} B_m + \frac{\partial \gamma_m}{\partial \eta} C_m \right] \sin \frac{m\pi x}{L} \\ \tau_{xz} = G \sum_{m=1}^M \left[\left(\frac{\partial \alpha_m}{\partial \zeta} + \eta \right) \Omega_m + \frac{\partial \beta_m}{\partial \zeta} B_m + \frac{\partial \gamma_m}{\partial \zeta} C_m \right] \sin \frac{m\pi x}{L} \end{cases} \quad (25)$$

III. BEAM WITH MONOCONNECTED CROSS-SECTION

In order to verify the feasibility of the applied theory and to compare it with the classical one, an application has been carried out for a beam already analyzed by C.J. Burgoyne and H. Brown (e.g. [6]), falling indisputably within the thin-wall domain. The aims of this application are:

1. to verify the convergence of the solution when the number of harmonics increases;
2. to make a comparison on the unit-twist angle and bimoment longitudinal distribution with the classical theory.

In Fig. 2 the section scheme is shown (all dimensions are in mm), while the other data useful in the analysis are:

| | | |
|--------------------------------|-----------------|-----------------------------|
| • Poisson modulus | ν | 0.3 (steel) |
| • Beam length | L | 3.6 m |
| • Vertical moment of inertia | I_η | 1.990607 E-5 m ⁴ |
| • Horizontal moment of inertia | I_ζ | 6.581881 E-6 m ⁴ |
| • Product of inertia | $I_{\eta\zeta}$ | 0 |
| • Polar moment of inertia | I_p | 2.648795 E-5 m ⁴ |

In Fig. 3 and Fig. 4 the convergence behaviour of the unit twist angle evaluated at $x=0.1$ m and $x=1.8$ m is shown, verifying that in this case 200 harmonics are sufficient to obtain a consistent solution.

Concerning the comparison with the classical Vlasov's theory, preliminarily it is necessary to evaluate the shear center position, located at a distance from the origin that can be determined according to the formula:

$$\eta_Q = \frac{\alpha_{03}}{I_\eta} = -0.10344 \text{ m} \quad (26)$$

having denoted by α_{03} the following integral:

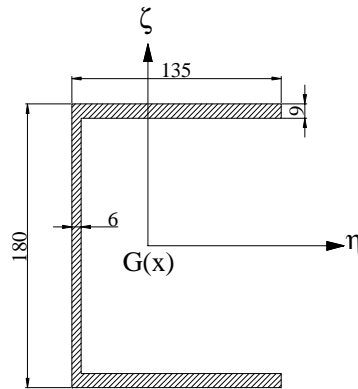

Fig. 2 Cross-section scheme

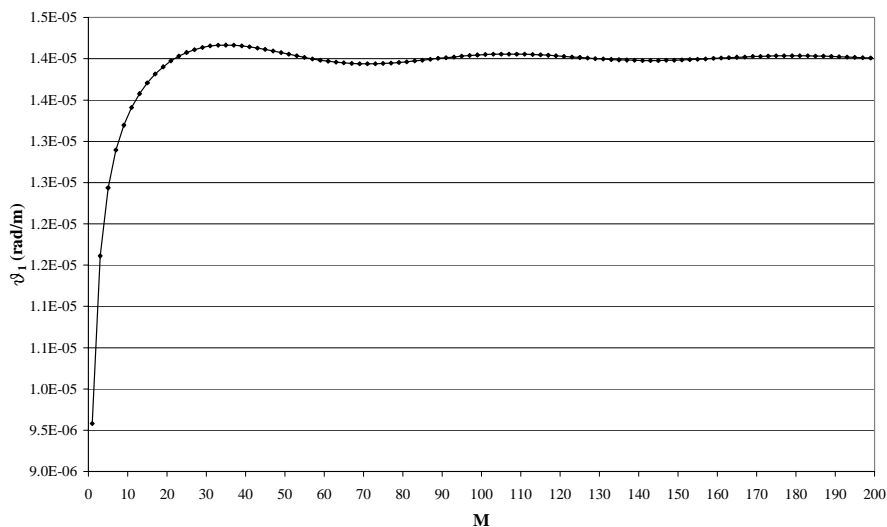

Fig. 3 Unit twist angle convergence $x = 0.1$ m

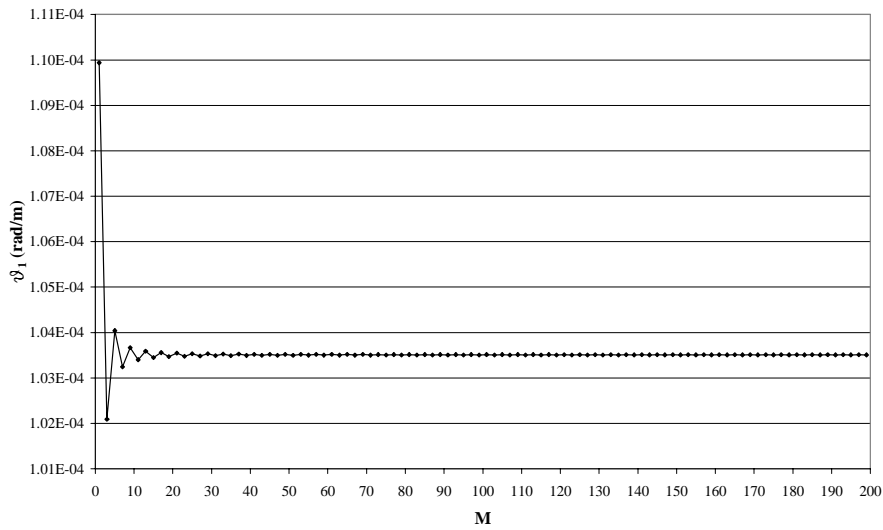

Fig. 4 Unit twist angle convergence x = 1.8 m

$$\alpha_{03} = -\int_A \zeta \alpha_0 dA \quad (27)$$

if $\alpha_0(\eta, \zeta)$ is solution of the equation (16.1) with $m=0$.

Then, according to the classical theory, the unit twist angle for $M_t(x) = M_t = const.$ can be so expressed:

$$\vartheta_1 = \frac{M_t}{GI_t} \left[1 - \cosh(\sqrt{\beta}x) - \frac{1 - \cosh(\sqrt{\beta}L)}{\sinh(\sqrt{\beta}L)} \sinh(\sqrt{\beta}x) \right] \quad (28)$$

having done the position:

$$\beta = \frac{GI_t}{EI_w} \quad (29)$$

In eq. (29) I_t is the torsional modulus, while I_w is the warping modulus, so defined for thin-walled beams:

$$I_t = \frac{1}{3} \sum_{i=1}^N l_{t_i}^3 = 7.64640E-8 \text{ m}^4 \quad (30)$$

$$I_w = \int_A (\alpha_0 - \zeta \eta_0)^2 dA = 3.51087E-8 \text{ m}^4 \quad (31)$$

In Fig. 6 the unit twist angle longitudinal distribution is shown for an applied torque assumed unitary. The continuous and dashed lines refer to the classical and exact theories, respectively. In Fig. 7 the bimoment longitudinal distribution is also shown: no appreciable differences are noticed between the two theories.

Finally, in table I (see also Fig. 5) the warping stresses in some chosen points of the cross-section in correspondence of the left beam end have been evaluated. In this case there is a good agreement with the values obtained applying the

classical theory, according to which the warping stresses can be explicated as follows:

$$\sigma_x = E \frac{d\vartheta_1}{dx} [\alpha_0(\eta, \zeta) + \zeta \eta_0] \quad (32)$$

TABLE I
WARPING STRESSES DISTRIBUTION

| η | ζ | $\sigma_{x-classical}$ | $\sigma_{x-exact}$ | $\left(\frac{\sigma_{x-classical}}{\sigma_{x-exact}} - 1 \right) \cdot 100$ |
|---------|---------|------------------------|--------------------|--|
| m | m | N/mm ² | N/mm ² | --- |
| 0.0850 | 0.0855 | 0.1817 | 0.1868 | -2.73 |
| 0.0214 | 0.0855 | 0.0246 | 0.0235 | 4.68 |
| -0.0461 | 0.0855 | -0.1421 | -0.1442 | -1.46 |
| -0.0461 | 0.0405 | -0.0672 | -0.0645 | 4.19 |
| -0.0461 | 0 | 0 | 0 | --- |

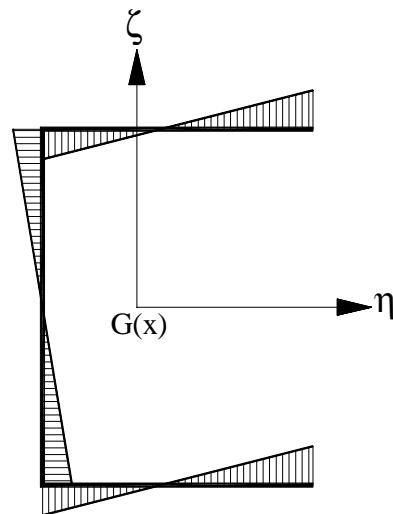

Fig. 5 Warping stresses distribution

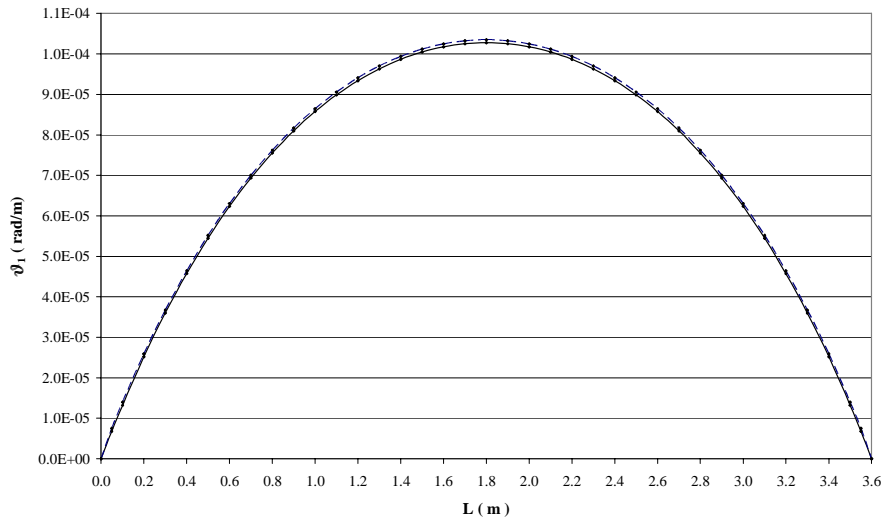

Fig. 6 Unit twist angle longitudinal distribution

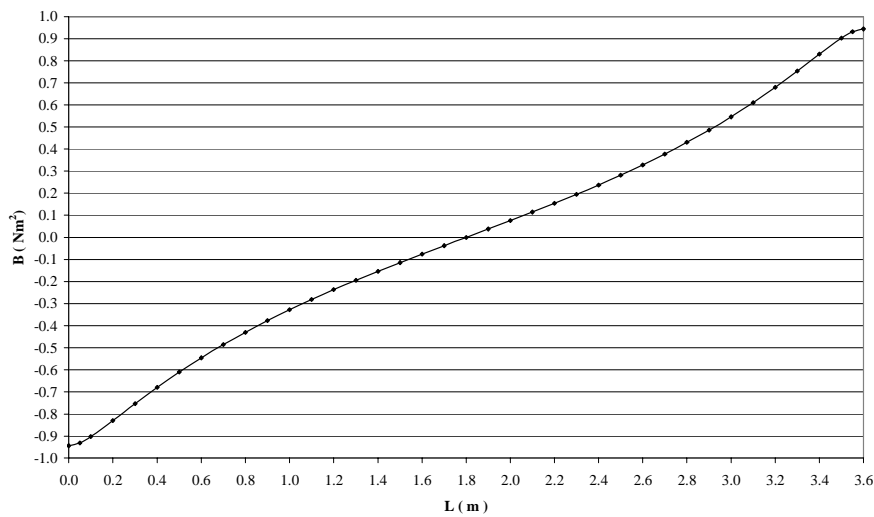

Fig. 7 Bimoment longitudinal distribution

IV. BEAM WITH PLURICONNECTED CROSS-SECTION

In the following application a simplified containership section is analyzed, in order to verify the feasibility of the proposed technique for the evaluation of the warping stress field. Particularly, the boundary conditions (11), in correspondence of two adjacent transverse bulkheads, can be adopted, as it is currently made in the practical scantling procedures. The section main data are the following:

- Poisson modulus $\nu = 0.3$ (steel)
- Beam length $L = 40$ m
- Cross section area $A = 2.50$ m²
- Vertical pos. of G above baseline $z_G = 5.81$ m
- Vertical position of twist center $\zeta_Q = -11.9$ m
- Vertical moment of inertia $I_\eta = 102.65$ m⁴

- Horizontal moment of inertia $I_\zeta = 325.07$ m⁴
- Product of inertia $I_{\eta\zeta} = 0$
- Polar moment of inertia $I_p = 427.72$ m⁴
- Torsional coefficient $I_t = 9.57$ m⁴
- Warping coefficient $I_w = 13917$ m⁶

In Fig. 8 the section scheme is presented, while in table II for each branch the first node, the second node, the length and the thickness are shown. In table III, assuming a constant applied torque equal to 10⁵ kNm, the warping stresses, evaluated applying the exact theory and the refined one of Hajdin and Kollbruner, are determined in correspondence of the left beam end section. See also Fig. 9 for the warping stress distribution over the cross-section, where the dashed and continuous lines refer to the classical and exact theories, respectively.

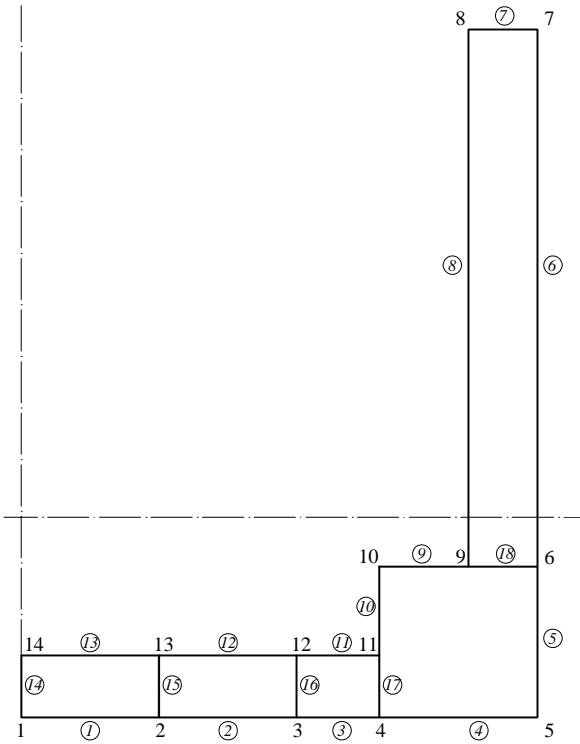

Fig. 8 Section scheme

TABLE II
SECTION GEOMETRY DATA

| Branches | I node | II node | t (mm) | l (m) |
|----------|--------|---------|----------|---------|
| 1 | 1 | 2 | 20 | 4.00 |
| 2 | 2 | 3 | 20 | 4.00 |
| 3 | 3 | 4 | 20 | 2.40 |
| 4 | 4 | 5 | 20 | 4.60 |
| 5 | 5 | 6 | 15 | 4.40 |
| 6 | 6 | 7 | 15 | 15.60 |
| 7 | 7 | 8 | 15 | 2.00 |
| 8 | 8 | 9 | 15 | 15.60 |
| 9 | 9 | 10 | 15 | 2.60 |
| 10 | 10 | 11 | 15 | 2.60 |
| 11 | 11 | 12 | 18 | 2.40 |
| 12 | 12 | 13 | 18 | 4.00 |
| 13 | 13 | 14 | 18 | 4.00 |
| 14 | 1 | 14 | 15 | 1.80 |
| 15 | 2 | 13 | 15 | 1.80 |
| 16 | 3 | 12 | 15 | 1.80 |
| 17 | 4 | 11 | 15 | 1.80 |
| 18 | 6 | 9 | 15 | 2.00 |

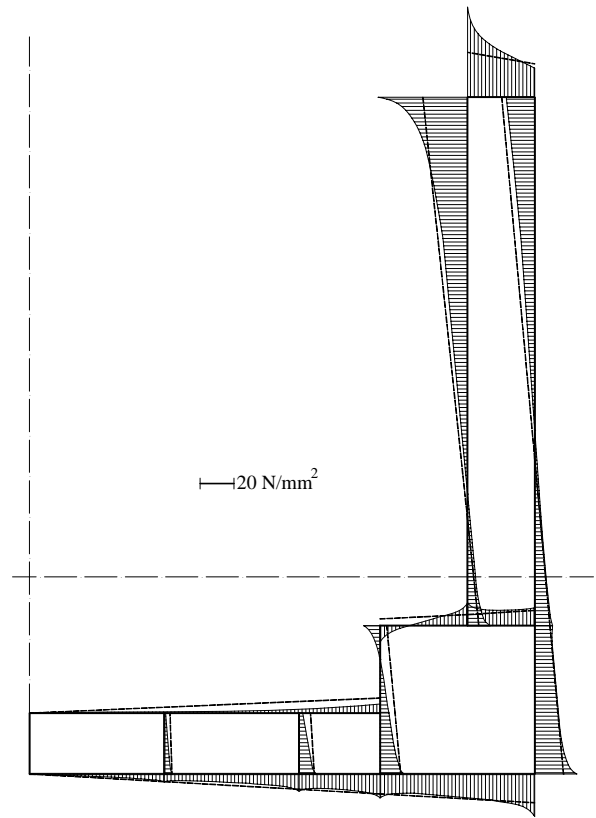

Fig. 9 Warping stresses distribution

TABLE III
WARPING STRESSES AT NODES

| Nodes | Exact | Classical | Δ |
|-------|-------------------|-------------------|--|
| | σ_{x-E} | σ_{x-C} | $\frac{\sigma_{x-C} - \sigma_{x-E}}{\sigma_{x-E}} \cdot 100$ |
| | N/mm ² | N/mm ² | % |
| 1 | 0.00 | 0.00 | --- |
| 2 | 4.70 | 4.44 | -5.53 |
| 3 | 10.24 | 8.90 | -13.09 |
| 4 | 14.26 | 11.61 | -18.58 |
| 5 | 25.05 | 17.01 | -32.10 |
| 6 | 10.48 | 9.44 | -9.92 |
| 7 | -17.08 | -19.63 | 14.93 |
| 8 | -53.11 | -26.44 | -50.22 |
| 9 | 13.47 | 6.75 | -49.89 |
| 10 | -9.73 | 3.92 | -140.29 |
| 11 | 5.28 | 8.85 | 67.61 |
| 12 | 2.16 | 6.83 | 216.20 |
| 13 | 0.77 | 3.42 | 344.16 |
| 14 | 0.00 | 0.00 | --- |

From Fig. 9 it's clear that the warping stress distribution over each branch isn't linear, as some stress concentrations arise, especially in correspondence of the intersections between branches.

Concerning the hull girder yielding check, for ships having large openings in the strength deck, its' well known that the normal stresses induced by torque, vertical and

horizontal bending moments have to be superimposed, by means of appropriate combination factors. The maximum warping stress values are reached in correspondence of the bottom-side and deck-inner side intersections, where the stresses induced by vertical and horizontal bending moments become maximum, too. From the analysis, the

following results have been obtained at the above mentioned intersections:

$$\text{- Bottom-side : } \sigma_{x-E} = 25.05 \text{ N/mm}^2 = 1.5 \sigma_{x-C}$$

$$\text{- Deck-inner side : } \sigma_{x-E} = 53.11 \text{ N/mm}^2 = 2.0 \sigma_{x-C}$$

Denoting by σ_B the combined vertical and horizontal bending moment stress, the total primary one, obtained adopting for the warping part the classical and the exact theories, respectively, can be so expressed:

$$\sigma_1 = \sigma_B + \sigma_{x-C} \quad (33)$$

$$\sigma_1^* = \sigma_B + \sigma_{x-E} \quad (34)$$

Thanks to the positions: $\sigma_{x-E} = \beta_C \sigma_{x-C}$ and $\sigma_{x-C} = \alpha_C \sigma_1$, the following percentage variation, as regards σ_1 , is obtained:

$$\Delta = \frac{\sigma_1^* - \sigma_1}{\sigma_1} \cdot 100 = \alpha_C (\beta_C - 1) \cdot 100 \quad (35)$$

so that for any $\beta_C > 1$, σ_1 is underestimated as regards σ_1^* , which is potentially higher than the admissible stress. For example, if $\alpha_C = 0.20$, assuming at bottom-side $\beta_C = 1.5$ and at deck-inner side $\beta_C = 2.0$, the relative percentage variations, as regards σ_1 , are $\Delta = 10\%$ and $\Delta = 20\%$, respectively.

V. CONCLUSIONS

In this paper a new theory for the non-uniform torsion of beams with asymmetric cross-section has been adopted. Despite of the classical theories, it isn't necessary to introduce the concept of a fixed center of twist, so regarding the non-uniform torsion as a combined flexure/torque problem. The displacement field has been developed into appropriate trigonometric series, so obtaining a generalized warping function that fully respects the first indefinite equilibrium equation. As the warping displacement and the unit twist angle functions have been developed into Fourier series, directly satisfying the beam boundary conditions, it

isn't necessary to impose the classical warping differential equation, too.

Two numerical examples have been proposed, in order to highlight the feasibility of the proposed theory and to compare it with the classical one.

Particularly, the first example, relative to an open profile, has been carried out in order to test the applied FE numerical procedure. The second one, instead, is relative to a simplified containership section, regarded as restrained against torsion in correspondence of two adjacent bulkheads. Particularly, it has been verified that the maximum warping stress values at bottom and deck are higher than the ones evaluated applying the classical theory, so that an appreciable influence on the hull girder scantling, arise.

Obviously, other examples are necessary to test the method and verify the effective influence of the exact non-uniform torsion theory on the scantling procedures: these problems will be the subjects of future works.

REFERENCES

- [1] R. Fiorenza, *Appunti delle lezioni di Analisi Funzionale*, Gli Strumenti di Coinor, 2005.
- [2] V. Vlasov, *Thin-walled elastic beams*, Jerusalem: Israel program for Scientific Translation Ltd, 1961.
- [3] A.D. Polyanin, *Linear partial differential equations for Engineers and Scientists*, CHAPMAN & HALL/CRC.
- [4] T. Coppola, E. Fasano, M. Mandarino, A. Turtoro, "The restrained warping applied to catamarans", *Fast '97 Papers*, 1997.
- [5] C.J. Burgoyne, H. Brown, "Non uniform elastic torsion", *International Journal of Mechanical Sciences*, Vol. 36, No. 1, pp. 23-38, 1994.
- [6] C.J. Burgoyne, H. Brown, "Non uniform elastic torsion and flexure of members with asymmetric cross-section", *International Journal of Mechanical Sciences*, Vol. 36, No. 1, pp. 39-48, 1994.
- [7] K. Haslum, A. Tonnensen, "An analysis of torsion in ship hulls", *European Shipbuilding*, No. 5/6, pp. 67-90, 1972.

A. Campanile. Full Professor of Offshore Structures at the University of Naples "Federico II" since 1990, SNAME Member, Degree in Naval and Mechanical Engineering in 1971.

M. Mandarino. Full Professor since 1990, Associate Professor in 1980, Masters Degree in Naval Architecture, Marine and Mechanical Engineering in 1974.

V. Piscopo. Third year Ph.D. student at the University of Naples "Federico II", First Degree in Naval Engineering in 2004, Second Degree in Naval Engineering in 2006.