

# Harmonic Analysis of 240 V AC Power Supply using TMS320C6713 DSK

Dody Ismoyo, Mohammad Awan, and Norashikin Yahya

**Abstract**—The presence of harmonic in power system is a major concerned to power engineers for many years. With the increasing usage of nonlinear loads in power systems, the harmonic pollution becomes more serious. One of the widely used computation algorithm for harmonic analysis is fast Fourier transform (FFT). In this paper, a harmonic analyzer using FFT was implemented on TMS320C6713 DSK. The supply voltage of 240 V 59 Hz is stepped down to 5V using a voltage divider in order to match the power rating of the DSK input. The output from the DSK was displayed on oscilloscope and Code Composer Studio™ software. This work has demonstrated the possibility of analyzing the 240V power supply harmonic content using the DSK board.

**Keywords**—Harmonic Analysis, DSP.

## I. INTRODUCTION

A harmonic of an electrical signal is the content of the signal whose frequency is an integer multiple of the fundamental system frequency. The caused of harmonic in a power system are from highly nonlinear devices. In power system, harmonic analysis is use to determine the impact of harmonic producing load on a power system. This technique is widely used for system planning, equipment design, troubleshooting, etc. The effect of harmonics on power system can be in the form of power efficiency reduction, overheating in wire, ageing of electrical insulation, etc [1] [2].

Several algorithms have been proposed on harmonic analysis [3]-[7] and fast Fourier transform (FFT) is the most widely used computation algorithm [7]-[9]. FFT is an efficient algorithm used to compute discrete Fourier transform (DFT). DFT uses a finite set of discrete-time sample of an analogue signal and produces a finite set of discrete-frequency magnitude spectrum values.

This paper focuses on implementation of 240V, 50Hz power supply harmonic analysis on DSK board using FFT technique. The organization of this paper is as follows; we described the design requirement of the DSK board and the methodology in Section II. In Section III, we will discuss the result from the implementations. Finally, Section IV gives the conclusion of the work.

Authors are with Electrical and Electronics Engineering, Universiti Teknologi PETRONAS, Bandar Seri Iskandar, 31750 Tronoh, Perak, Malaysia (corresponding author: Dody Ismoyo; e-mail: juzaf@yahoo.com).

## II. METHODOLOGY

### A. TMS320C6713 DSK Board

TMS320C6713 DSK, [10] developed by Texas Instrument with Spectrum Digital, is a floating point digital signal processor (DSP) used as a low-cost development platform. The kit uses universal serial bus (USB) communication for true plug-and-play functionality. The sampling frequency of the board is 32 kHz.

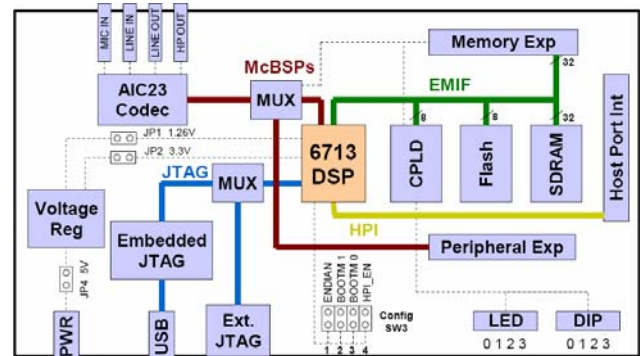

Fig. 1 Block diagram of TMS320C6713 DSK [11]

The DSK board has an ADC/DAC build inside AIC Codec with 16-bit resolution. The block diagram of the DSK showing the ports and components is shown in Fig. 1. This work uses the ADC and DAC features on the board inside the AIC23 Codec shown in Fig. 2.

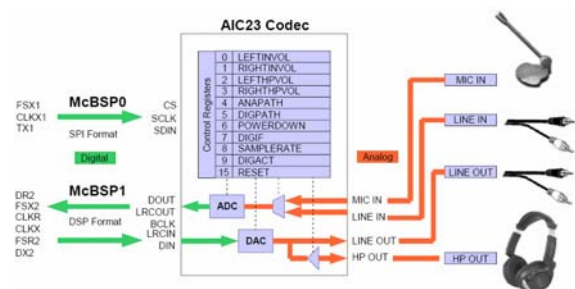

Fig. 2 Codec Interface of TMS320C6713 DSK [11]

The complete circuit of a power supply harmonic analyzer is shown in Fig. 3. Here, the DSK board is connected to a computer for output display in Code Composer Studio™ (CCS™) software. The oscilloscope is used to display the time-domain output from the DSK.

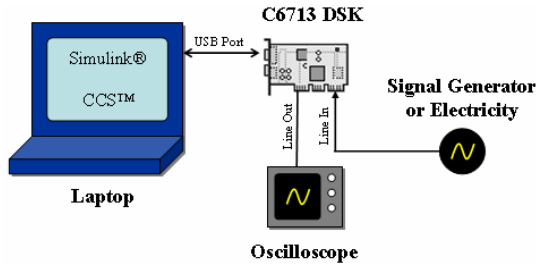

Fig. 3 Configuration for harmonic analyzer

The Simulink® 6.3 blocks of MATLAB® 7.1 (minimum) are used to initialize the DSK board as an ADC for power supply input. The sampling rate of the ADC is set at 32 kHz and the input setting on the ADC source is *Line In*. The Simulink® blocks used for the initialization are shown in Fig. 4. The C6713DSK block must be placed in the Simulink® model to set the target preferences and memory map to generate code for the DSK.

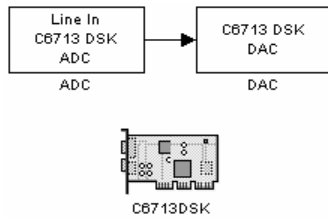

Fig. 4 ADC, DAC and C6713DSK blocks for DSK initialization

**B. Harmonic Display on CCS™**

The settings for graph display on CCS™ are summarized in Table I. Some detail explanations on the important parameters are as follows:

- a. Display Type: *FFT Magnitude*  
FFT Magnitude is chosen to display the frequency spectrum or harmonic contents of the input signal.
- b. Start Address: *adc2\_B.ADC*  
The start address is taken from the CCS™ ADC Real-Time Workshop Coding. *adc2\_B.ADC* is the final output at the S-Function Block.
- c. FFT Order: *10*  
Selecting the higher order of the FFT will give a more accurate program, but it will take more time to run.
- d. FFT Windowing Function: *Rectangle*  
Rectangle windowing function is selected so that only some particular region of the whole signal frequency spectrum is being analyzed.
- e. Sampling Rate (Hz): *200*  
For 50 Hz input signal, the sampling rate should be at least twice of the highest frequency of the signal being analyzed. Thus, sampling frequency of 200 Hz is sufficient for this application.

**III. RESULT**

To analyze the harmonic component of the 240V power supply using the DSK, first, it has to be stepped down to 5 V in order to match the power rating of the DSK board *Line in*. The power supply is stepped down using i) voltage divider

ii) 240 V/6 V step-down transformer. The time domain plot for the input and output of the DSK board is displayed on an oscilloscope while the frequency domain plot is obtained on the CCS™.

TABLE I  
GRAPH PROPERTY DIALOG SETTING

Graph Property Dialog	
Display Type	FFT Magnitude
Graph Title	Graphical Display
Signal Type	Real
Start Address	adc2_B.ADC
Acquisition Buffer Size	128
Index Increment	1
FFT Framesize	100
FFT Order	10
FFT Windowing Function	Rectangle
Display Peak and Hold	Off
DSP Data Type	8-bit signed integer
Q-Value	0
Sampling Rate (Hz)	200
Plot Data From	Left to right
Left-shifted Data Display	No
Autoscale	On
DC Value	0
Axes Display	On
Frequency Display Unit	Hz
Status Bar Display	On
Magnitude Display Scale	Linear
Data Plot Style	Bar
Grid Style	Full Grid
Cursor Mode	Data Cursor

To match the power rating of the DSK board, a voltage divider circuit using power resistors (17 W) is being used to step down the incoming voltage from 240 V to 5 V. The value of power resistors used are 940 Ω and 44 kΩ, based on the following calculations for current withdrawn, voltage across resistor and power dissipated by resistors respectively:

$$I = \frac{V}{R_1 + R_2} = \frac{240}{44,000 + 940} = 5.34 \text{ mA}$$

$$V = \frac{R_{940}}{R_{940} + R_{44,000}} \times V_s = \frac{940}{940 + 44,000} \times 240 = 5.02 \text{ V}$$

$$P_{44,000} = I^2 \times R_{44,000} = 0.00534^2 \times 44,000 = 1.25 \text{ W}$$

$$P_{940} = I^2 \times R_{940} = 0.00534^2 \times 940 = 0.03 \text{ W}$$

The full construction of the circuit and the DSK board is shown in Fig. 5.

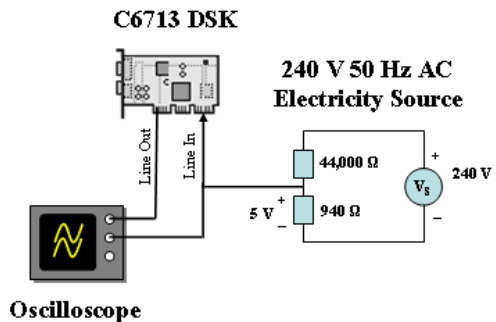

Fig. 5 Harmonic analysis circuit of power supply using a voltage divider

The total current drawn by the DSK from the voltage source is 5.34 mA, which is a safe value for the DSK. The voltage across the 940  $\Omega$  resistor is 5.02 V, which closely match the requirement for the DSK board.

The input and output wave of the DSK is shown in Fig. 6. The input and the output of the DSK look slightly different because of the effect of digitalization done at the DSK stage. However, most of the frequency content of the input signal is preserved in the output which is very important since we are mainly interested in the frequency content of the signal.



Fig. 6 Time domain plot of input (top) and output (bottom) of the DSK for circuit configuration in Fig. 5

The digitized wave is being read by the DSK board in digital form. From the frequency spectrum display in CCS™, the frequency spectrum of the 50 Hz 5 V AC sinusoidal wave is being displayed in Fig. 7. It shows a peak at the 50 Hz frequency axis which corresponds to the fundamental frequency of the electrical supply and at the 0 Hz frequency axis which corresponds to the DC components, where it is not a pure sinusoidal wave.

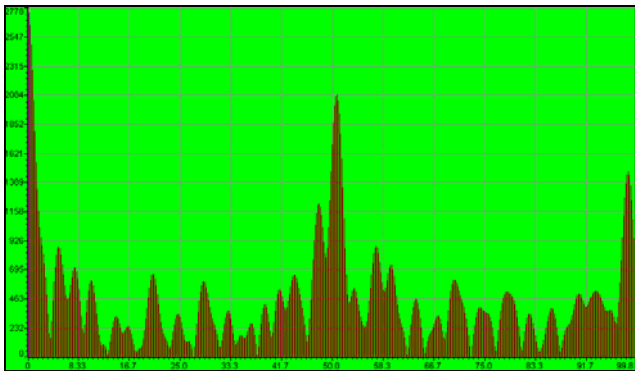

Fig. 7 Frequency spectrum of 50 Hz 5 V AC sinusoidal wave from electricity outlet

For real-time harmonic analysis, FFT Waterfall selection from the Display Type of the Graph Property Dialog in CCS™ is used. The frequency spectrum of the power supply is being displayed at different instances whenever the refresh command is executed as shown in Fig. 8. It consistently shows high peaks at 0 Hz and 50 Hz which correspond to the majority DC component and the 50 Hz fundamental frequency component respectively.

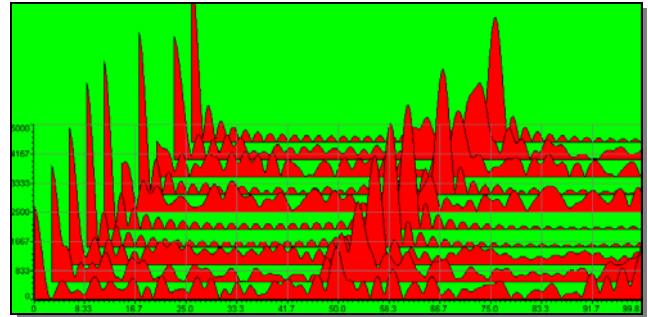

Fig. 8 Real-Time FFT plot of the DSK output for circuit configuration in Fig. 5

#### IV. CONCLUSION

A technique of power supply harmonic analyzer in frequency domain using TMS320C6713 DSK was presented. The output from a voltage divider circuit does not really give a pure sinusoidal waveform. This is because the power resistors also generate harmonics in the down-converted voltage which can be seen from the presence of more ripples in the sine wave. The developed harmonic analyzer has correctly displayed peaks at 0 Hz and 50 Hz on FFT plots which correspond to the DC component and the 50 Hz fundamental frequency component of power supply respectively.

#### REFERENCES

- [1] E. Acha and M. Madrigal, *Power Systems Harmonics*. West Sussex: John Wiley & Sons, Ltd, 2001.
- [2] J. Arrillaga and N. R. Watson, *Power System Harmonics*. 2nd ed. Christchurch: John Wiley & Sons Ltd, 2003.
- [3] A. Mehraei and B. Porat, "Adaptive comb filtering for harmonic signal enhancement," *IEEE Trans. Acoust. Speech Signal Processing*, vol. ASSP-34, no. 5, pp. 1124–1138, Oct. 1986.
- [4] G. Takata, et al., "The time-frequency analysis of the harmonics with wavelet transform for the power electronics systems," in *Proc. Power Conversion Conf.*, vol. 2, Apr. 2002, pp. 733–737.
- [5] Y. Z. Liu and S. Chen, "A wavelet based model for on-line tracking of power system harmonics using Kalman filtering," in *Proc. IEEE Power Engineering Society Summer Meet.*, vol. 2, Jul. 2001, pp. 1237–1242.
- [6] H. Xue and R. Yang, "A novel algorithm for harmonic measurement in power system," in *Proc. Int. Conf. PowerCon*, vol. 1, Oct. 2002, pp. 438–442.
- [7] M. Meunier and F. Brouaye, "Fourier transform, wavelets, Prony analysis: tools for harmonics and quality of power," in *Proc. 8th Int. Conf. Harmonics Quality Power*, vol. 1, Oct. 1998, pp. 71–76.
- [8] A.A. Girgis, *The Fast Fourier Transform and Its Applications*. Upper Saddle River, NJ: Prentice-Hall, 1990.
- [9] A. N. Mortensen and G. L. Johnson, "A power system digital harmonic analyzer," *IEEE Trans. Instrum. Meas.*, vol. 37, no. 4, pp. 537–540, Dec. 1988.
- [10] Texas Instruments Incorporated. (2008). TMS320C6713 DSP Starter Kit (DSK). Texas Instruments. Retrieved 23 June 2008 from <http://focus.ti.com/docs/toolsw/folders/print/tm320c6713.html>.
- [11] N.N. TMS320C6713 DSK Technical Reference. 2003 ed. Texas: Spectrum Digital Incorporated, 2003.