

# Real Time Compensation of Machining Errors for Machine Tools NC based on Systematic Dispersion

M. Rahou, A. Cheikh, and F. Sebaa

**Abstract**—Manufacturing tolerancing is intended to determine the intermediate geometrical and dimensional states of the part during its manufacturing process. These manufacturing dimensions also serve to satisfy not only the functional requirements given in the definition drawing, but also the manufacturing constraints, for example geometrical defects of the machine, vibration and the wear of the cutting tool. In this paper, an experimental study on the influence of the wear of the cutting tool (systematic dispersions) is explored. This study was carried out on three stages. The first stage allows machining without elimination of dispersions (random, systematic) so the tolerances of manufacture according to total dispersions. In the second stage, the results of the first stage are filtered in such way to obtain the tolerances according to random dispersions. Finally, from the two previous stages, the systematic dispersions are generated. The objective of this study is to model by the least squares method the error of manufacture based on systematic dispersion. Finally, an approach of optimization of the manufacturing tolerances was developed for machining on a CNC machine tool.

**Keywords**—Dispersion, Compensation, modeling, manufacturing Tolerance, machine tool.

## I. INTRODUCTION

MANUFACTURING tolerancing is intended to determine the intermediate geometrical and dimensional states of the part during its manufacturing process. These manufacturing dimensions also serve to satisfy not only the functional requirements given in the definition drawing, but also the manufacturing constraints, for example geometrical defects of the machine, vibration and the wear of the cutting tool...

Many research works were treated the tolerancing problem with different approaches, Rong and Bai [1] analyzed a dependent relationship of operational dimensions to estimate machining errors in terms of linear and angular dimensions of a workpiece. Cai et al. [2] proposed a method to conduct a robust fixture design to minimize workpiece positional errors as a result of workpiece surface and fixture setup errors. Djurdjanovic and Ni [3] developed procedures for determining the influence of errors in fixtures, locating datum features and measurement datum features on dimensional errors in machining. These studies were conducted when a static case was assumed.

Kim and Kim [4] have developed a volumetric error model based on 4x4 homogenous transformation for generalized geometric error. Eman and Wu [5] have developed error model accounts for error due to inaccuracies in the geometry and mutual relationships of the machine structural elements as well as error resulting from the relative motion between these elements. Kakino et al. [6] have measured positioning errors of multi-axis machine tools in a volumetric sense by Double Ball Bar (DBB) device. Takeuchi and Watanabe [7] have shown five-axis

control collision free tool path and post processing for NC-data.

In the work of [8], the authors present an experimental semi study of the vibratory behavior of the cutting tool goods of the operation of slide-lathing, is the object to show that it is possible to consider the roughness average of the part machined starting from displacement resulting from the nozzle of the tool. In the work of [9] a study was presented on the influence of the position of the cutting tool on dynamic behavior in milling of thin walls, and in work of [10,11,12], authors thus illustrate the influence of the trajectory of the cutting tool on the surface quality tolerances of manufacture for machining on the machine tool has numerical control.

## II. SOURCE OF ERROR

Before we look at how the task of error compensation can be achieved, we need to clearly understand what we mean by accuracy and error. Accuracy could be defined as the degree of agreement or conformance of a finished part with the required dimensional and geometrical accuracy [13]. Error, on the other hand, can be understood as any deviation in the position of the cutting edge from the theoretically required value to produce a workpiece of the specified tolerance. The extent of error in a machine gives a measure of its accuracy; that is the maximum translation error between any two points in the work volume of the machine. This of course depends on the resolution of the system. Positioning can never be more accurate than this as there will be no further feedback to improve the positioning within this range. However, more important than system resolution, are the errors that occur between the measurement point and the feedback point [14]. The best way to keep track of the errors is to formulate an error budget. An error budget allocates resources among the different components of a machine. It is a system analysis tool used for the prediction and control of the total error of a system. An error budget basically addresses two fundamental issues. One involves obtaining the influence of different sources of error (the individual members of the kinematic chain of the machine tool) on the accuracy of the machine. The other involves taking a set of specifications and determining the permissible level of each source so that some criterion like cost etc., is optimised [15]. Errors can be classified into two categories namely quasi-static errors and dynamic errors. Quasi-static errors are those between the tool and the workpiece that are slowly varying with time and related to the structure of the machine tool itself. These sources include the geometric/kinematic errors, errors due to dead weight of the machine's components and those due to thermally induced strains in the machine tool structure. Dynamic errors on the other hand are caused by sources such as spindle error motion, vibrations of the machine

structure, controller errors etc. These are more dependent on the particular operating conditions of the machine. Quasistatic errors account for about 70 percent of the total error of the machine tool and as such, are a major focus of error compensation research. Once the individual error components have been identified, the next step in the problem of error budgeting is to determine the optimal level of these errors so that the cost factor is minimised [15].

In general, a machining centre consists of a bed, column, spindle and its slide and the various linear and/or rotary axes. Each of these elements contributes to the total error of the system that is represented by the error budget. Errors can broadly be classified as:

- a) Geometric errors of machine components and structures
- b) Kinematic errors
- c) Errors induced by thermal distortions
- d) Errors caused by cutting forces including
  - (i) by gravity loads
  - (ii) by accelerating axes, and
  - (iii) by the cutting action itself
- e) Material instability errors
- f) Machine assembly-induced errors
- g) Instrumentation errors
- h) Tool wear
- i) Fixturing errors and
- j) Other sources of errors like servo errors of the machine (following errors and interpolation algorithmic errors) [16,17,18].

#### A. Geometric and Kinematic Errors

Geometric errors are those errors that are extant in a machine on account of its basic design, the inaccuracies built-in during assembly and as a result of the components used on the machine.

As such, they form one of the biggest sources of inaccuracy. These errors are concerned with the quasi-static accuracy of surfaces moving relative to one another. Geometric errors can be smooth and continuous or they could exhibit hysteresis or random behaviour. These errors are affected by factors like surface straightness, surface roughness, bearing pre-loads etc. Geometric errors have various components like linear displacement error (positioning accuracy), straightness and flatness of movement of the axis, spindle inclination angle, squareness error, backlash error etc [17]. Kinematic errors are concerned with the relative motion errors of several moving machine components that need to move in accordance with precise functional requirements. These errors are particularly significant during the combined motion of different axes as in the case of gear hobbing or profile machining where co-ordination of rotary with respect to linear axes or linear with respect to linear axes is of prime importance. Such errors occur during the execution of linear, circular or other types of interpolation algorithms and are more pronounced during actual machining.

#### B. Thermal Errors

Another principal cause for inaccurate workpieces is error due to improper tool positioning on account of thermal deformation. It is well understood that errors due to thermal factors account for 40–70% of the total dimensional and shape errors of a workpiece in precision engineering [19].

Six sources of thermal influence are identified: (i) heat from the cutting process, (ii) heat generated by the machine, (iii) heating or cooling provided by the cooling systems, (iv) heating or cooling influence of the room, (v) the effect of people and (vi) thermal memory from any previous environment [19]. Critical among these sources is heat generated by the machine. Continuous running of the machine causes heat to be generated at the moving elements as a result of frictional resistance, at the motors, in pumps etc [20]. This heat causes relative expansion of the various elements of the machine tool leading to inaccurate positioning of the cutting tool tip.

Consequently errors due to spindle growth, thermal expansion of the ballscrews and thermal distortion of the column are generated at the tool tip. As heat generation at contact points is unavoidable, this source of error is one of the most difficult to eliminate completely. In the manufacture of precision components error due to thermal deformation of the machine elements plays a vital role in limiting the accuracy of the part produced.

#### C. Cutting-force Induced Errors

The dynamic stiffness of all the components of the machine tool (namely the bed, column, etc.) that are within the force–flux flow of the machine is responsible for errors caused as a result of the cutting action. This is one of the major sources of error in metal-cutting machines as the force involved in the cutting action is considerable. As a result of the forces, the position of the tool tip with respect to the workpiece varies on account of the distortion of the various elements of the machine. Depending on the stiffness of the structure under the particular cutting conditions, the accuracy of the machine tool would vary. Thus, for a machine with a given stiffness a heavy cut would generally produce more inaccurate components than a light cut.

#### D. Other Errors

Other errors like tool wear and fixturing errors add to the overall inaccuracy of the machined component. Errors in fixturing are caused by fixture set-up and geometric inaccuracies of the locating elements and by fixture flexure. In cases where the workpiece is restrained by a small area of contact with the fixture, the errors due to deformation or lift-off of the workpiece could cause significant errors. Workpiece displacement is dependent on several factors like position of the fixturing elements, clamping sequence, clamping intensity, type of contact surface etc. Thus workpiece displacement could be a significant source of machine error.

### III. SYSTEMATIC DISPERSION

Systematic dispersion is due primarily to the wear of the cutting tool between the realization of the first part and the last part of a given series (Fig. 1).

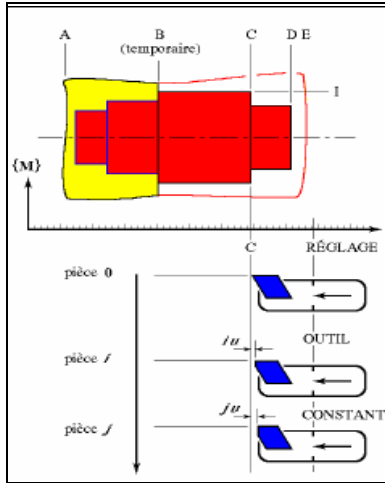

Fig. 1 The wear of tool [22]

The wear of the tool leads us to make an experimental study which makes it possible to show the influence of systematic dispersion on the manufacturing tolerances.

IV. PROCEDURE OF THE TESTS

It is difficult, if not impossible; to obtain manufacturing tolerances while being limited only to systematic dispersions. For this reason, it is necessary to take into account all dispersions. In order to achieve this goal, there are three stages:

1st stage:

The machining of the parts is done without the elimination of dispersions (random, systematic) so that one finds the manufacturing tolerances according to total dispersions.

2nd stage:

The results of the first stage were filtered in such way that one only finds the tolerances of manufacture according to random dispersions.

3rd stage:

From the two previous stages, we compute the systematic dispersions.

V. CONDITIONS OF THE TESTS

We have machined 40 parts, C35 matter, on lathe with numerical control using a facing tool with standard brought back pastille “J11ER”

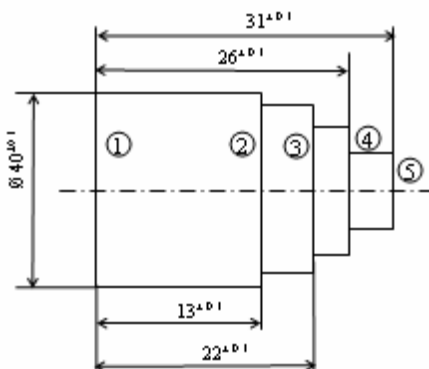

Fig. 2 Design drawing of the workpiece

We place the test in the following conditions:

- The wear of the tool is a linear function;
- Thermal balance is reached;
- Geometrical dispersion is immersed in random dispersion;
- The machining of surface 1 is carried out under phase with the same tool;

VI. STAGES OF MANUFACTURE

After having presented the procedure, let us detail the three stages of the study:

A. First Stage

Starting from a crude, we carried out 5 surfaces on a lathe white numerical control, (Fig. 3), by respecting the following parameters of the cut:

- Cutting speed:  $Cs = 80$  m/mn;
- Speed in advance:  $F = 0.05$  mm/tr;
- machining without lubrication;
- Depth of cut = 2 mm;

A program of machining was developed under a language FANUC (Fig. 3), for the realization of these tests:

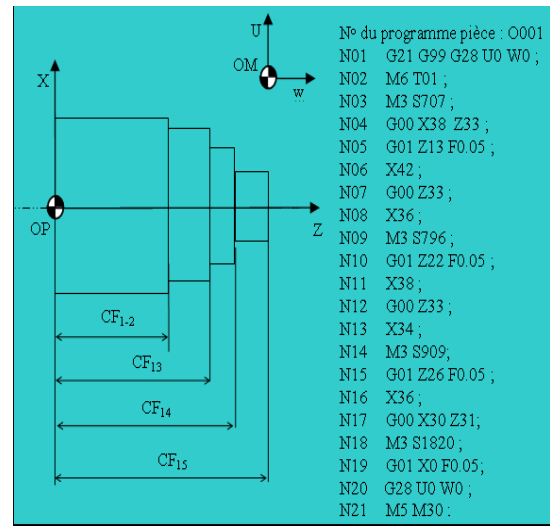

Fig. 3 Sketch of phase of tuning

On each part of the series, we measures dimensions d12, d13, d14, d15 and we calculates d23.

From the equations (1), (2) and (3), we gives the statistical results (the average  $\bar{X}$ , the standard deviations  $\sigma_{ij}$  and  $\Delta CF_{ij}$ ) illustrated in Table I.

| TABLE I<br>STATISTICAL RESULTS OF THE 1ST STAGE |                |               |                       |
|---|----------------|---------------|-----------------------|
|   | $\bar{X}$ (mm) | $\delta$ (mm) | $\Delta CF_{ij}$ (mm) |
| d12   | 13.0052        | 3.489 10-2    | 2.093 10-1            |
| d13   | 22.0074        | 2.860 10-2    | 1.716 10-1            |
| d14   | 26.0076        | 3.199 10-2    | 1.917 10-1            |
| d15   | 31.0141        | 2.685 10-2    | 1.611 10-1            |
| d23   | 9.0020         | 3.369 10-2    | 2.021 10-1            |

$$\bar{x} = \frac{1}{N} \sum_{i=1}^N n_i x_i \quad (1)$$

$$v(x) = \sum_{i=1}^N \frac{n_i}{N} (x_i - \bar{x})^2 \quad (2)$$

$$\sigma = \sqrt{v(x)} \quad (3)$$

The system (5), is deduced by the equation (4)

$$\Delta CF_{ij} = \Delta l_i + \Delta l_j \quad (4)$$

$$\begin{cases} \Delta CF_{12} = \Delta l_1 + \Delta l_2 \\ \Delta CF_{13} = \Delta l_1 + \Delta l_3 \\ \Delta CF_{14} = \Delta l_1 + \Delta l_4 \\ \Delta CF_{25} = \Delta l_2 + \Delta l_5 \\ \Delta CF_{23} = \Delta l_2 + \Delta l_3 \end{cases} \quad (5)$$

The resolution of the system (5) leads to the solutions (6):

$$\begin{cases} \Delta l_1 = 8.949 \cdot 10^{-2} \text{ mm} \\ \Delta l_2 = 1.200 \cdot 10^{-1} \text{ mm} \\ \Delta l_3 = 8.221 \cdot 10^{-2} \text{ mm} \\ \Delta l_4 = 1.029 \cdot 10^{-1} \text{ mm} \\ \Delta l_5 = 7.199 \cdot 10^{-2} \text{ mm} \end{cases} \quad (6)$$

The results (6) represent total dispersions.

**B. Second Phase**

In this stage, formula (7) was used to filter dimensions of the first stage.

$$d_{a_{ij}} = d_{t_{ij}} - \frac{\Delta CF_{s_{ij}}}{N} i \quad (7)$$

$\Delta CF_{s_{ij}}$  : The variation of the dimensions manufactured with systematic dispersion;

$d_{a_{ij}}$  : Filtered dimensions;

$d_{t_{ij}}$  : Dimensions according to total dispersion;

$i$  : Number of test;

To calculate  $\Delta s_{ij}$ , we trace for each dij the graphs (dij (N)) and average lines, Figs. 4, 5, 6, 7, 8.

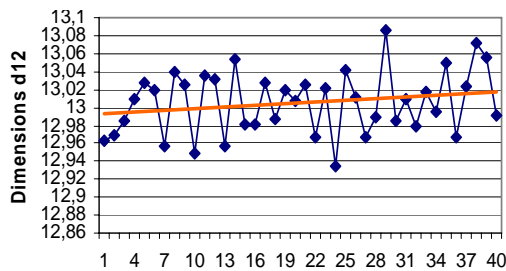

Fig. 4 Graph of dimensions d12

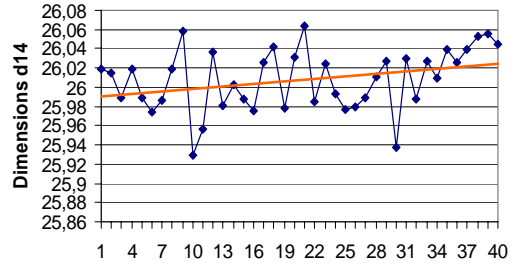

Fig. 5 Graph of dimensions d14

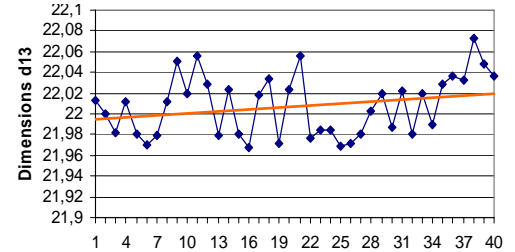

Fig. 6 Graph of dimensions d13

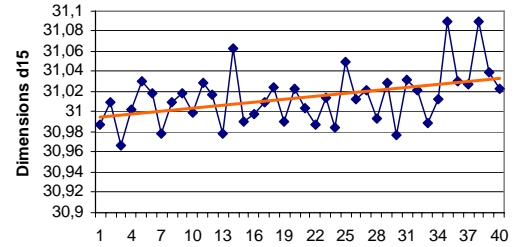

Fig. 7 Graph of dimensions d15

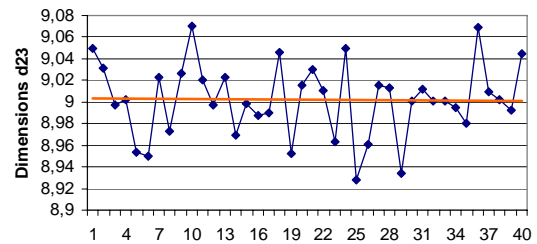

Fig. 8 Graph of dimensions d23

The variation of manufacture, expression (8), is given according to the average line tangent  $a_{ij}$  and of the tests number N.

$$\Delta CF_{s_{ij}} = a_{ij} \cdot N \quad (8)$$

The resolution of the system (8) gives the results of  $\Delta CF_{s_{ij}}$ , represented by (9).

$$\begin{cases} \Delta CF_{s_{12}} = 2.656 \cdot 10^{-2} \text{ mm} \\ \Delta CF_{s_{13}} = 2.508 \cdot 10^{-2} \text{ mm} \\ \Delta CF_{s_{14}} = 3.428 \cdot 10^{-2} \text{ mm} \\ \Delta CF_{s_{15}} = 3.816 \cdot 10^{-2} \text{ mm} \\ \Delta CF_{s_{23}} = 0.169 \cdot 10^{-2} \text{ mm} \end{cases} \quad (9)$$

From the equation (7) and the system (9), calculation gives new dimensions ( $d_{a_{ij}}$ ).

Table II represents the statistical results calculated starting from the equations (1), (2) and (3)

| TABLE II<br>STATISTICAL RESULTS OF THE 2ND STAGE |        |                        |                        |
|--|--------|------------------------|------------------------|
|  | X (mm) | $\delta$ (mm)          | $\Delta CFa_{ij}$ (mm) |
| da12   | 12.992 | 3.403 10 <sup>-2</sup> | 2.041 10 <sup>-1</sup> |
| da13   | 21.995 | 2.767 10 <sup>-2</sup> | 1.661 10 <sup>-1</sup> |
| da14   | 25.991 | 3.042 10 <sup>-2</sup> | 1.825 10 <sup>-1</sup> |
| da15   | 30.995 | 2.448 10 <sup>-2</sup> | 1.469 10 <sup>-1</sup> |
| da23   | 9.003  | 3.369 10 <sup>-2</sup> | 2.021 10 <sup>-1</sup> |

According to the equation (10), there is the system of expressions (11)

$$\Delta CFa_{ij} = \Delta la_i + \Delta la_j \quad (10)$$

$$\begin{cases} \Delta CFa_{12} = \Delta la_1 + \Delta la_2 \\ \Delta CFa_{13} = \Delta la_1 + \Delta la_3 \\ \Delta CFa_{14} = \Delta la_1 + \Delta la_4 \\ \Delta CFa_{25} = \Delta la_2 + \Delta la_5 \\ \Delta CFa_{23} = \Delta la_2 + \Delta la_3 \end{cases} \quad (11)$$

The resolution of the system (11) leads to the solutions (12):

$$\begin{cases} \Delta a_1 = 8.379 \cdot 10^{-2} \text{ mm} \\ \Delta a_2 = 1.199 \cdot 10^{-1} \text{ mm} \\ \Delta a_3 = 8.200 \cdot 10^{-2} \text{ mm} \\ \Delta a_4 = 9.824 \cdot 10^{-2} \text{ mm} \\ \Delta a_5 = 6.279 \cdot 10^{-2} \text{ mm} \end{cases} \quad (12)$$

The results of system (12) represent random dispersions.

### C. Third Stage

In this stage we trace the graphs of the dimensions filtered (daij) according to many tests (N).

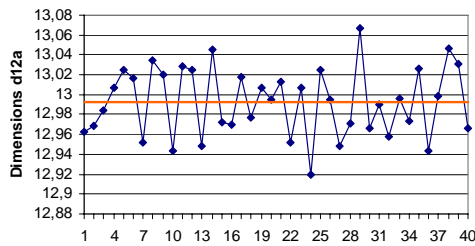

Fig. 9 Graph of dimensions da12

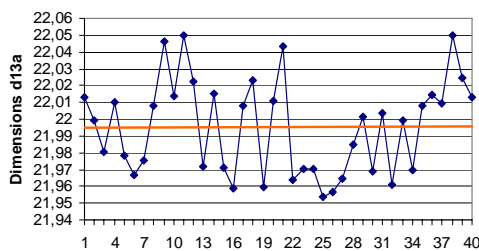

Fig. 10 Graph of dimensions da13

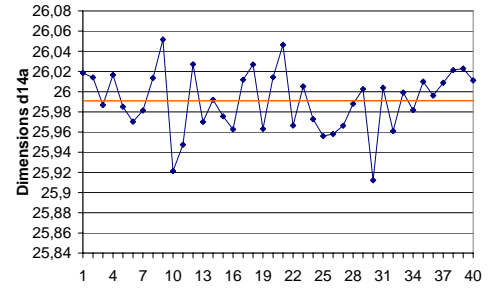

Fig. 11 Graph of dimensions da14

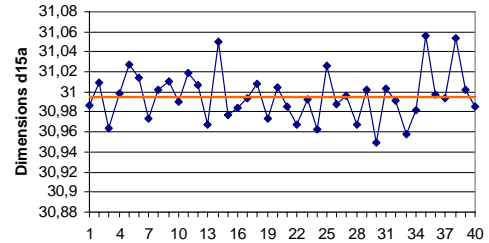

Fig. 12 Graph of dimensions da15

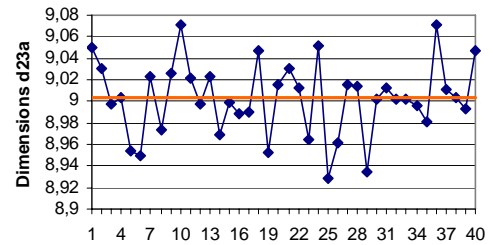

Fig. 13 Graph of dimensions da23

According to Figs. 9, 10, 11, 12, 13, we notice that the tangents are equal to zero. Therefore filtering is made completely. The replacement of the equation (13) in the system (14), leads to the system (15).

$$\Delta CFs_{ij} = \Delta s_i + \Delta s_j \quad (13)$$

$$\begin{cases} \Delta CFs_{12} = 2.656 \cdot 10^{-2} \text{ mm} \\ \Delta CFs_{13} = 2.508 \cdot 10^{-2} \text{ mm} \\ \Delta CFs_{14} = 3.428 \cdot 10^{-2} \text{ mm} \\ \Delta CFs_{15} = 3.816 \cdot 10^{-2} \text{ mm} \\ \Delta CFs_{23} = 0.169 \cdot 10^{-2} \text{ mm} \end{cases} \quad (14)$$

$$\begin{cases} \Delta s_1 = 2.497 \cdot 10^{-2} \text{ mm} \\ \Delta s_2 = 0.158 \cdot 10^{-2} \text{ mm} \\ \Delta s_3 = 0.00105 \cdot 10^{-2} \text{ mm} \\ \Delta s_4 = 0.931 \cdot 10^{-2} \text{ mm} \\ \Delta s_5 = 1.319 \cdot 10^{-2} \text{ mm} \end{cases} \quad (15)$$

The results of system (15) represent systematic dispersion.

## VII. INTERPRETATION OF THE RESULTS

Table III presents a recapitulation of the results of the dispersions calculated in the three stages.

TABLE III  
RESULTS OF CALCULATED DISPERSIONS

|           | <b>Total dispersion</b><br>(mm) | <b>Random dispersion</b><br>(mm) | <b>Systematic dispersion</b><br>(mm) |
|-----------|---------------------------------|----------------------------------|--------------------------------------|
| Surface 1 | $0.895 \cdot 10^{-1}$           | $0.837 \cdot 10^{-1}$            | $2.497 \cdot 10^{-2}$                |
| Surface 2 | $1.200 \cdot 10^{-1}$           | $1.199 \cdot 10^{-1}$            | $0.158 \cdot 10^{-2}$                |
| Surface 3 | $0.822 \cdot 10^{-1}$           | $0.819 \cdot 10^{-1}$            | $0.105 \cdot 10^{-3}$                |
| Surface 4 | $1.029 \cdot 10^{-1}$           | $0.982 \cdot 10^{-1}$            | $0.931 \cdot 10^{-2}$                |
| Surface 5 | $0.719 \cdot 10^{-1}$           | $0.627 \cdot 10^{-1}$            | $1.319 \cdot 10^{-2}$                |
| Summon    | $4.667 \cdot 10^{-1}$           | $4.462 \cdot 10^{-1}$            | $0.490 \cdot 10^{-1}$                |

In Fig. 17 the graph of total dispersion is almost confused with the graph of random dispersion. The influence of systematic dispersions on the tolerances of manufacture is minimal Compared to random dispersions.

The greatest value of systematic dispersions (Fig. 14) is on surface 1 used like reference surfaces, due to the influence of the machined surfaces 2, 3, 4, 5, and the grinding problem of the tool.

On the other hand the greatest value of random dispersions (Fig. 15) is on the level of surface 2, then surface 4. The order of surfaces is not imperative; it has a relationship to the setting in position of the part in the chuck, the quality of tightening (manual or pneumatic) or the stop materializing the fifth point of isostatism. The smallest value is at the level of surface 3, since the latter is between two machined surfaces characterized by a small machining length.

The values of systematic dispersions are very small relative with total dispersion. The sum of the values of systematic dispersions is about 10% of the sum of total dispersions. Therefore random dispersion accounts for 90% of total dispersion.

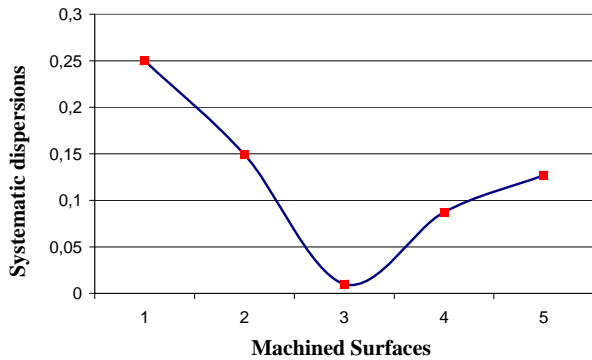

Fig. 14 Systematic dispersions according to the machined surfaces

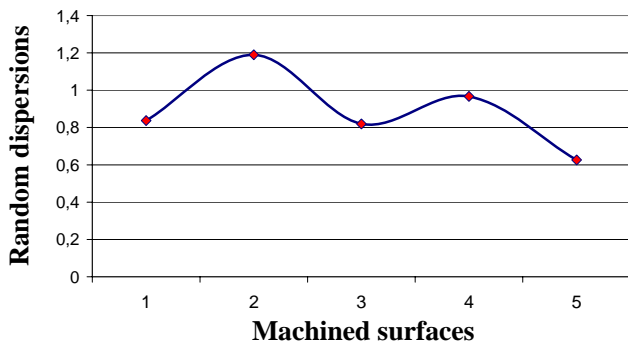

Fig. 15 Random dispersions according to the machined surfaces

Fig. 16 represents the evolution of total dispersions according to the machined surfaces.

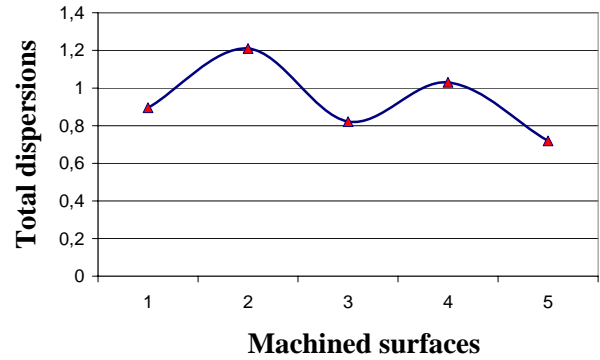

Fig. 16 Total dispersions according to the machined surfaces

Fig. 17 illustrates a comparison between total dispersions and random dispersions.

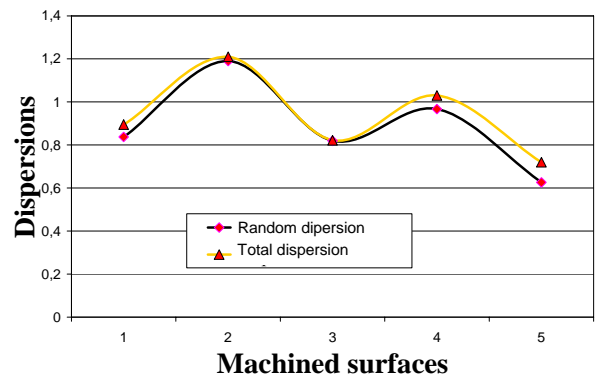

Fig. 17 Comparison enters total and random dispersions

Fig. 18 illustrates the percentage between the sum of the values of systematic dispersions and the sum of the values of total dispersions.

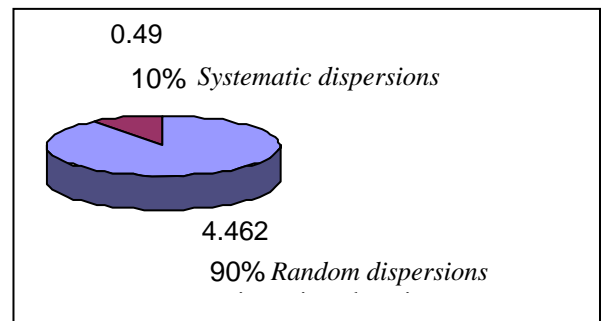

Fig. 18 Statistical representation by sector between systematic dispersion and random dispersion

### VIII. ERRORS MODELING

In this part, a modeling of the errors of dispersions was worked out by the method of Lagrange to develop two models of correction of the tolerances. In the first model, equation 16, we can calculate tolerances of manufacture due to systematic dispersion according to the machined length. In the second model, equation 17, we can calculate tolerances of manufacture according to the machined length.

$$IT = 6,5 \cdot 10^{-4} \sqrt[3]{D} + 1,3 \cdot 10^{-5} \cdot D + 1,2 \cdot 10^{-5} \quad (16)$$

$$IT = 0.05 \sqrt[3]{D} + 10^{-3} \cdot D + 10^{-3} \quad (17)$$

After the integration of tolerancing models in the numerical command control program, the new statistical results are given by the Table VI.

According to the results, the variations of manufacture (tolerance of manufacture) were decrease by 55 %.

TABLE IV  
STATISTICAL RESULTS

|     | X (mm)  | $\delta$ (mm) | $\Delta CF_{ij}$ (mm) |
|-----|---------|---------------|-----------------------|
| d12 | 13.0022 | 0.01958       | 0.11748               |
| d13 | 22.0024 | 0.01867       | 0.11202               |
| d14 | 26.0016 | 0.01874       | 0.11244               |
| d15 | 31.0031 | 0.01685       | 0.1011                |
| d23 | 9.0002  | 0.02269       | 0.13614               |

## IX. CONCLUSION

In this work, a step centered on three stages, was presented to calculate dispersions of machining and their influence on the intervals of tolerances. The influence of systematic dispersion accounts for 10% of the total discrepancies under the conditions normal and between 25% and 35%, if the parameters of cut or the cutting tool are badly selected.

The relative value of 10% of the tolerance is very important especially in work in series; because the wear of the tool influences the dimensions of adjustment. An error about the micron influences the overall costs of the end product and risk to guarantee the competitiveness of the product on the market.

Two models of compensation the error in the tool machine numerical control were developed, the first models it is the calculation of systematic dispersion according to the machined length; for the second it is the calculation of the tolerances of manufacture (total dispersions) according to the machined length. These models allowed us optimize the manufacturing dimensions, that is to say by integration in the command balls or in the machining programming.

## REFERENCES

- [1] Rong Y., Bai Y. Machining accuracy analysis for computer-aided fixture design verification. *J Manuf Sci Eng* 118:289–300(1996).
- [2] Cai W, Hu SJ et al A variational method of robust fixture configuration design for 3-D workpieces. *J Manuf Sci Eng* 119:593–602(1997).
- [3] Djurdjanovic D, Ni J. Dimensional errors of fixtures, locating and measurement datum features in the stream of variation modeling in machining. *J Manuf Sci Eng Trans ASME* 125(4):716–730 (2003).
- [4] K. Kim, M.K. Kim, Volumetric accuracy analysis based on generalized geometric error model in multi-axis machine tools, *Mech. Mach. Theory* 26 (2) 207–219 (1991).
- [5] K.F. Eman, B.T. Wu, A Generalized error model for multi-axis machines, *Annals of the CIRP* 36 (1) 253–256 (1987).
- [6] Y. Kakino, Y. Ihara, A. Shinohara. Accuracy Inspection of NC Machine Tools by Double Ball Bar Method. Hanser Publishers, Munich, Germany 191, (1993).
- [7] Y. Takeuchi, T. Idemura, Generation of five-axis control collision free tool path and post processing for NC-data, *Annals of the CIRP* 41 (1) 539–542 (1992).
- [8] N .Ouelaa, N .Kribes, A .Rezaiguia, M.A Yaltese Etude semi-expérimentale du comportement vibratoire de l'outil de coupe lors de l'opération de chariotage " 5th internationale conference cpi 2003 Rabat.

- [9] T. Vincent, A .Lionel, D. Gilles, C .Gilles Influence de la position de l'outil sur le comportement dynamique en fraisage de parois minces", *Mécanique & Industries* 6 403–410 (2005).
- [10] L. Sotiris, C .Andreas. Nearchoub A CNC machine tool interpolator for surfaces of cross-sectional design" *Robotics and Computer-Integrated Manufacturing* 23 (2007) 257–264 (2007).
- [11] L. Andre, S. Klaus Investigation of tool path interpolation on the manufacturing of die and molds with HSC technology" *Journal of Materials Processing Technology* 179 (2006) 178–184.
- [12] Eing-Jer Wei, Ming-Chang Study on general analytical method for CNC machining the free-form surfaces" *Journal of Materials Processing Technology* 168 (2005) 408–413.
- [13] J. Jedrzejewski, W. Modrzycki, Intelligent supervision of thermal deformations in high precision machine tools, *Proc. 32nd Int. MATADOR Conf, Manchester, UK, 1997*, pp. 457–462.
- [14] T.J. Morris, The REAL Accuracy of machine tools, *Proc. 3rd Int. Conf. on Laser Metrology and Machine Performance — LAMDAMAP, 1997*, pp. 113–122.
- [15] C.J. Evans, R.J. Kocken, Self-calibration: reversal, redundancy, error separation and absolute testing, *Annals of the CIRP* 45 (2) (1996) 617–632.
- [16] M.A. Donmez, A general methodology for machine tool accuracy enhancement: theory, application and implementation, PhD dissertation, Purdue University, 1985.
- [17] J. Ni, CNC machine accuracy enhancement through real-time error compensation, *ASME Trans Journal of Manufacturing Science and Engineering* 119 (1997) 717–724.
- [18] A.H. Slocum, *Precision Machine Design*, Prentice Hall, 1992.
- [19] J. Bryan, International status of thermal error research, *Annals of the CIRP* 39 (2) (1990) 645–656.
- [20] R. Venugopal, Thermal effects on the accuracy of numerically controlled machine tools, PhD dissertation, Purdue University, (1985).
- [21] P. Bourdet, Chaînes de cotes de fabrication (Méthode des delta 1): deuxième partie Mode opératoire" *L'ingénieur et le Technicien de l'Enseignement Technique, ENS, Cachan.* (2003).
- [22] Guy M. Cloutier, FAO et Machines-Outils simulation d'usinage", *Mec4510, ENS, Cachan.* (2002).

**Mohamed Rahou** was born in Tlemcen Province, Algeria, in 1979. He received his Eng. 2003 and Magister ,2006, in mechanical engineering from Abou Bakr Belkaid University, Algeria . Dr RAHOU is currently a lecturer in the Department of Sciences and technical Abou Bakr Belkaid University, Tlemcen, Algeria. His areas of interest are: Tolerancing and Numerical Command.