

Experimental Study of Fuel Tank Filling

Maurizio Mastroianni, Lou Savoni, Paul Henshaw and Gary W. Rankin

Abstract—The refueling of a transparent rectangular fuel tank fitted with a standard filler pipe and roll-over valve was experimentally studied. A fuel-conditioning cart, capable of handling fuels of different Reid vapor pressure at a constant temperature, was used to dispense fuel at the desired rate. The experimental protocol included transient recording of the tank and filler tube pressures while video recording the flow patterns in the filler tube and tank during the refueling process. This information was used to determine the effect of changes in the vent tube diameter, fuel-dispense flow rate and fuel Reid vapor pressure on the pressure-time characteristics and the occurrence of premature fuel filling shut-off and fuel spill-back. Pressure-time curves for the case of normal shut-off demonstrated the classic, three-phase characteristic noted in the literature. The variation of the maximum values of tank dome and filler tube pressures are analyzed in relation to the occurrence of premature shut-off.

Keywords—experimental study, fuel tank filling, premature shut-off, spill-back

I. INTRODUCTION

POTENTIAL problems may exist during the automotive refueling process due to the configuration of the fuel system, complexity of the fuel characteristics and fuel tank geometry. Problems that occur during refueling include fuel-dispensing nozzle premature shut-off (PSO), fuel spitting (spit-back) and fuel spilling out of the filler pipe (spill-back) [1]. The latter two difficulties are safety concerns during refueling of the vehicle. Also, the escape of liquid fuel or hydrocarbon vapors out of the fuel tank system during refueling is a source of air pollution. In some countries, the release of hydrocarbon vapors into the atmosphere (except in emergency situations) is not permitted at petrol stations. In many cases they are required to collect displaced fuel vapors using a gas recovery system and transfer the gases back to the delivery system [2].

M. Mastroianni was with Kautex Textron Corporation in Windsor, Ontario. He is now with Investors Group, Windsor, ON, N9A 5K3 Canada (phone: 519-253-3553; e-mail: maurizio.mastroianni@investorsgroup.com).

L. Savoni was with Kautex Textron Corporation in Windsor, Ontario. He is now with Windsor Mold Group – Automotive Components Division, Windsor, Ontario, N8X 2H2 Canada (phone: 519-258-3211; e-mail: lsavoni@windsormoldgroup.com).

P. Henshaw is with the Civil and Environmental Engineering Department, University of Windsor, Windsor, Ontario, N9B 3P4 Canada (phone: 519-253-3000 Ext. 2588; e-mail: henshaw@uwindsor.ca).

G. W. Rankin is with the Mechanical, Automotive and Materials Engineering Department, University of Windsor, Windsor, Ontario, N9B 3P4 (phone: 519-253-3000 Ext. 2626; e-mail: rankin@uwindsor.ca).

II. BACKGROUND

In order to comprehend the implications of this study it is necessary to understand the components and processes involved in the refueling of an automotive fuel tank, the operation of a fuel-dispensing nozzle and related considerations such as premature shut-off mechanisms and vapor management techniques applied to fuel systems regarding hydrocarbon emissions.

A typical automotive fuel tank and refueling system is shown in Fig. 1. It consists of the fuel tank which usually contains a certain amount of residual fuel, a fuel pump and a filler pipe to allow connection to the fuel dispensing nozzle during refueling. It also is fitted with a number of vents to relieve the pressure within the tank during refueling. One venting path is through the line that leads to the upper part of the filler pipe and the air/vapor mixture following this route eventually exhausts out into the atmosphere, is entrained into the fuel that is being dispensed or is captured in a vapor management device. Ideally, the fuel flow during refueling is used to create a dynamic seal (liquid seal) within the fuel filler pipe to prevent the hydrocarbon vapors from entering the atmosphere through the filler pipe opening. The other venting path, through the roll-over valve (ROV), carries the vapors to a carbon canister. The carbon canister adsorbs the hydrocarbons and prevents them from entering the atmosphere. During engine operation, the purge valve opens, allowing the vacuum manifold to draw fresh air through the carbon canister to desorb the hydrocarbons and carry them into the engine for combustion [3].

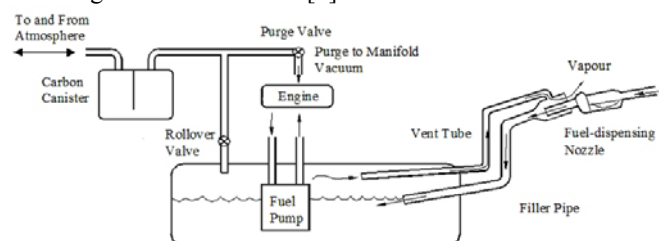

Fig. 1 Schematic diagram of an automotive fuel tank system

The fueling event in which a normal shut-off (NSO) occurs can be separated into three phases as described by Sinha *et al.* [4]. During Phase I the pressure in the tank vapor dome increases as indicated in Fig. 2. As the two-phase mixture enters the tank, phase separation occurs where the fuel vapor occupies the vapor space and liquid deposits at the bottom of the tank. The liquid level continues to rise, which displaces the air/fuel vapor mixture from the tank via the various venting paths. Due to venting, a constant pressure phase

(Phase II) is maintained throughout a major portion of the refueling process. Phase III begins when the fuel level rises and fuel enters the vent tube opening. At this point the air/vapor mixture in the tank is essentially trapped. With continued filling, the pressure in the tank increases, which reduces the rate at which fuel enters the fuel tank. The nozzle however, continues to dispense fuel, therefore increasing the level of fuel in the filler pipe until it covers the sensing port on the fuel-dispensing nozzle and the fuel-dispensing nozzle shuts off. If the fuel-dispensing nozzle shuts off before the fuel tank has been filled up to the level of the vent tube, PSO occurs.

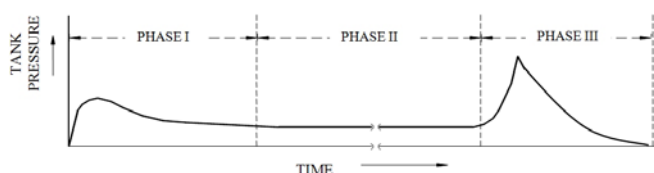

Fig. 2 Typical fuel tank dome pressure profile during refueling

During Phase II, Garrett [3] observed similar events during the refueling of the fuel tank. In addition, he used a ball-check-valve at the lower end of the filler pipe to ensure that the sudden increase in back-pressure during Phase III did not result in spill-back.

The detailed construction and operation of a fuel-dispensing nozzle is explained by Holloway [5]. The basic operation depends upon air entrainment through a sensing port near the nozzle exit. When liquid fuel covers the sensing port it reduces the entrainment which triggers a release mechanism, stopping the flow of fuel.

A. Premature Shutoff Mechanisms

Premature shut-off can be attributed to a number of factors. Poor design of the filler pipe, which results in a misalignment of the fuel-dispensing nozzle relative to the filler pipe, can lead to PSO. If the fuel-dispensing nozzle is directed towards the wall of the filler pipe the fuel could be deflected off the wall towards the fuel-dispensing nozzle. This situation increases the probability that the sensing port will be covered by fuel and that the fuel dispenser will shut off.

Any geometrical feature that tends to restrict the flow in the filler pipe could cause PSO. Once the flow is restricted, fuel accumulates in the filler pipe and the fuel level rises. If the liquid level continues to rise, it will eventually cover the sensing port on the fuel-dispensing nozzle, causing the fuel flow to shut off. Factors that would affect the restriction in the filler pipe are the radii of the bends and any reduction in area throughout the path in the filler pipe.

During refueling, the liquid entering the fuel tank forces the air/vapor mixture in the tank into an increasingly smaller region. This has the effect of increasing the tank pressure. The top of the tank is vented to relieve this pressure. The amount of venting is controlled by a combination of the leakage space for the vapor around the fuel-dispensing nozzle, the size and length of the lines connecting components of the fuel tank, the flow resistance of the roll-over valve, and the

adsorption and resistance characteristics of the carbon canister. The tank back-pressure is both an undesirable feature and a necessity. Too much back-pressure for too long of a duration, will cause PSO and/or poor fill quality. Overfilling the fuel tank can occur if not enough back-pressure is generated when the tank is full.

B. Factors Affecting Spit-back and Spill-back

A fuel-dispensing nozzle that does not shut-off automatically when the liquid level in the filler pipe has been sensed will cause spill-back. Also, if the fuel-dispensing nozzle is malfunctioning such that the response time taken to halt the liquid flow is too long, spill-back of fuel will occur. Additionally, there could be cases, at petrol stations, where the pumps used to dispense fuel from the underground storage tank to the vehicle are adjusted to a very high rate of flow. If the flow rate is too great the liquid level in the filler pipe can rise so fast that the delay between the sensing and actual shut-off causes overflow of fuel and spill-back.

Spit-back may be caused by droplets of fuel becoming entrained in the air/vapor which enters the atmosphere from the filler tube. This is more evident during cases of generation of high fuel vapors.

III. OBJECTIVES

Little information is available in the open literature regarding the physical processes occurring during the refueling of an automotive fuel tank. This lack of available experimental data is the main reason for conducting the experiments described and discussed in this paper. The goal of this project is to develop a better understanding of the factors that influence the quality of the refueling process and to obtain quantitative information. In order to accomplish this an experimental study was performed to determine how vent tube diameter, fuel Reid Vapor Pressure (RVP), and fill rate affect the occurrence of PSO, spit-back and spill-back. The experiments were restricted to the consideration of a simple tank shape, one type of fuel-dispensing nozzle with an optimum alignment of the fuel-dispensing nozzle with the filler pipe.

IV. EXPERIMENTAL FACILITY

This section includes a description of the equipment that was employed during the experimentation followed by the procedures that were used in obtaining the experimental results. The experimental equipment consisted of the test fuel tank, filler tube and vent tube as well as the fuel-dispensing nozzle which is part of the dispensing cart. The data acquisition arrangement details are also given.

A. Fuel Tank Filler Pipe and Vent Tube Arrangement

The rectangular fuel tank used in this study has dimensions 30.5 cm x 30.5 cm x 91.5 cm and was vacuum formed from transparent polyethylene terephthalate (PETG) in order to facilitate the visualization of flow within the tank. Special fixtures are used to attach the pressure transducer, temperature

sensor and vent tube using O-ring seals and fuel resistant sealant (DOW CORNING[®] 730 Solvent Resistant Sealant) to ensure that the components would be leak free. The fuel tank was submerged under water for thirty seconds and subjected to a gauge pressure of approximately 20 kPa to visibly detect and repair any leaks. The configuration of the fuel tank, filler pipe and vent tube is shown in Fig. 3. This arrangement was fixed for the duration of the experiments in order to have repeatable tests.

To reduce variability in the results due to differences in the fuel-dispensing nozzle location, a fixture with a locator pin was fabricated. This fixture ensured repeatability of setup for every refueling test.

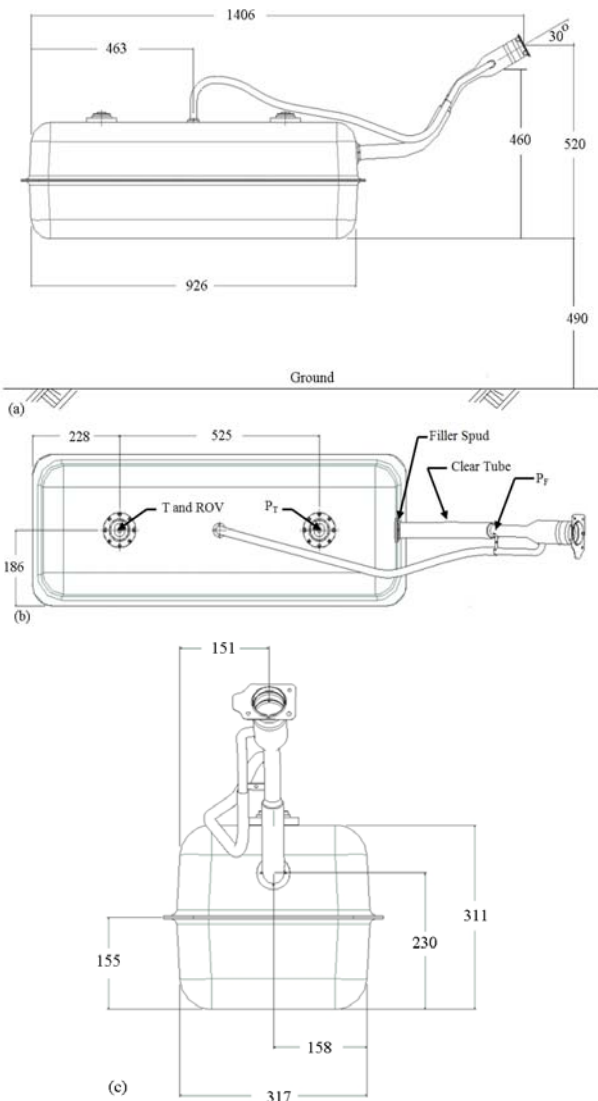

Fig. 3(a) Front view of the fuel tank system (b) Top view of the fuel tank system (c) Right side view of the fuel tank system. PF = filler pipe pressure location, PT = tank dome pressure location, T = temperature sensor and ROV = roll-over valve locations. All dimensions in mm

B. Fuel Conditioning Cart

A fuel-conditioning cart (Model FCD100) designed and manufactured by Richmond Instruments and Systems Incorporation was used to dispense the fuel. The fuel cart was set to condition the fuel at the desired temperature (21.1 °C) and dispense the fuel at one of the required flow rates (38 or 45 L/min). The fuel cart has a storage capacity of approximately 200 litres and is shown in Fig. 4.

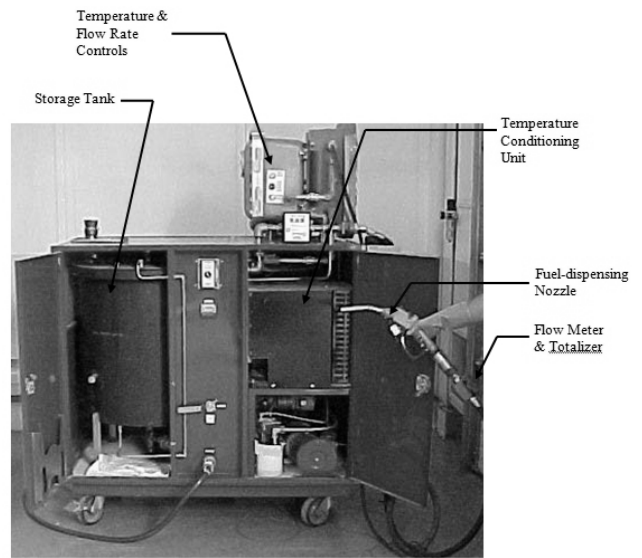

Fig. 4 The fuel-conditioning cart

C. Instrumentation and Data Acquisition System

The arrangement of the pressure transducers and thermocouple is illustrated on the schematic diagram of the fuel tank system shown in Fig. 5. The pressure and temperature values were collected and recorded at a sampling rate of 10 samples per second during the experiment.

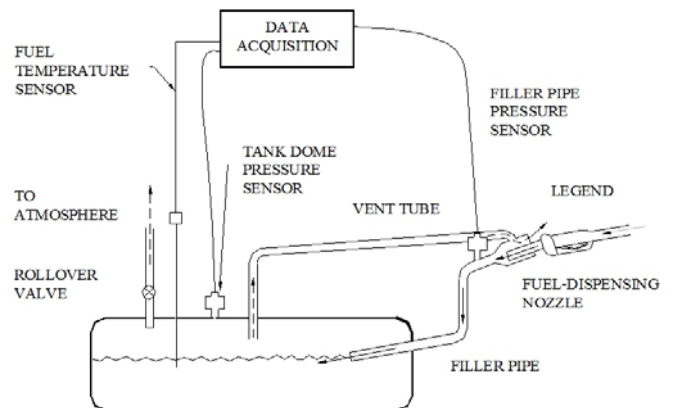

Fig. 5 Schematic diagram of the instrumented fuel tank system

The program used for collecting and storing data was written using LabVIEW[™] and the data acquisition system is indicated schematically in Fig. 6.

The data acquisition board was a National Instruments[™] 16-bit resolution I/O DAQ board (Model # AT-MIO-16XE-50). A set of SCXI low noise cables (Model #1349), which guaranteed reliable communication and signal integrity, linked the DAQ board to the

SCXI-1100 chassis. The SCXI-1100 chassis was a low-noise chassis house that routed analog and digital signals and powered and controlled the SCXI-1120 module. Signal conditioning was accomplished by using the SCXI-1120 Module. Three channels were utilized on the SCXI-1120 module each of which includes an isolated amplifier and a low-pass filter [6]. The terminal block (Model # SCXI-1328) included isothermal construction that minimizes errors caused by thermal gradients between terminals and the high-precision cold-junction sensor. Between the sensors and the terminal block were the Pepperl+Fuchs® shunt Zener diode barriers (Model numbers Z960 and Z787). Model number Z960 was used for the temperature sensor, while the Z787 was used for the two 4-20 mA pressure transducers. Two pressure transducers manufactured by Druck, Model PTX 610, were used during testing. The accuracy of these transducers including non-linearity, hysteresis and repeatability was $\pm 0.08\%$ full scale. A type K thermocouple with an accuracy $\pm 1^\circ\text{C}$ was used to record fuel temperature during refueling.

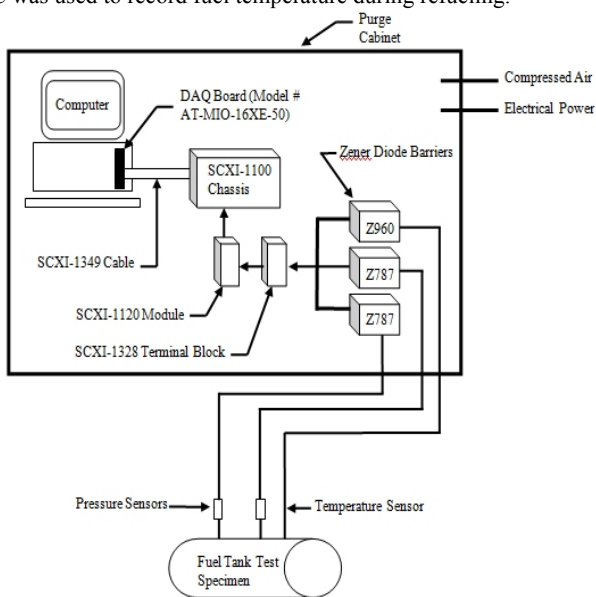

Fig. 6 Data acquisition system layout

The Zener diode barriers act as safety interfaces between intrinsically safe and non-intrinsically safe circuits. They are designed to limit the amount of energy that can be transferred from a safe to a hazardous area in the event of fault conditions occurring in the safe area [7].

The safe area was considered to be located within the purge cabinet. All the hardware mentioned previously (excluding the sensors) was enclosed within the purge cabinet as illustrated in Fig. 6. Since the hardware requires a source of electricity, which could lead to sparking, the purge cabinet must maintain a positive pressure of approximately 60 mbar. Should the purge cabinet (safe area) not maintain its positive pressure, the source of electricity would be cut-off, subsequently an immediate shutdown occurs. In addition, if in the purge cabinet a fault condition occurs (voltage increase relative to the reference voltage), a fuse will open isolating the safe and hazardous area. The pressure measurement system, (*i.e.* A/D converters and transducers combination) was calibrated using a Druck Incorporated pressure calibrator (Model DPI603) which supplied known pressures and had an accuracy of $\pm 0.075\%$ full scale. Twelve points from -5.2 kPa to 13.8 kPa inclusive were used for calibration. The overall test set-up including the data acquisition and fuel conditioning cart is illustrated in Fig. 7.

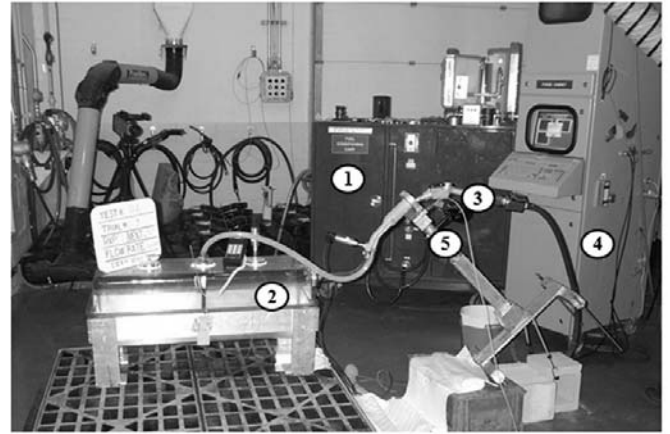

Fig. 7 Overall experimental arrangement. (1 = Fuel Cart, 2 = Test Fuel Tank, 3 = Fuel-dispensing Nozzle, 4 = Purge Cabinet, 5 = Fuel-dispensing Nozzle Fixture)

D. Experimental Conditions

The values of the parameters studied are represented in the matrix shown in Table I. It should be emphasized that changes in the fuel RVP, fuel flow rate and inside diameter of the vent tube are investigated.

The parameters that remained constant throughout each test were; the relative position of the vapor line, filler pipe and fuel-dispensing nozzle (constant to within ± 5 mm), fuel temperature ($19^\circ\text{C} \pm 1^\circ\text{C}$), simulated ROV orifice diameter ($1.6 \text{ mm} \pm 0.1 \text{ mm}$), vent tube length ($37.1 \text{ mm} \pm 0.1 \text{ mm}$), and room temperature ($21^\circ\text{C} \pm 1^\circ\text{C}$).

TABLE I
TEST MATRIX INDICATING EXPERIMENTAL CONDITIONS.

Test Number	Vent Internal Diameter (mm)	Flowrate (L/min)	Reid Vapor Pressure (kPa)
1	9.5	38	83
2	9.5	45	83
3	9.5	38	55
4	9.5	45	55
5	6.4	38	55
6	6.4	45	55
7	6.4	38	83
8	6.4	45	83
9	3.2	38	83
10	3.2	38	55
11	3.2	45	55
12	3.2	45	83
13	3.2	45	7
14	3.2	38	7

D. Tank Conditioning

The first fueling test conducted on a tank is referred to as the "green test" due to the fact that the tank has never been in contact with fuel. In order to eliminate the green tank effect the tank was initially refueled several times. For each test number, three repetitions were performed. The tank dome pressure, filler pipe pressure and tank temperature were monitored throughout. Calibration fluid (Trade Name: MS-4957 Calibration Fluid) available from Gage Products Company, located in Ferndale Michigan, was used in these

tests. Calibration fluid has similar properties to gasoline, except that is not as volatile as gasoline. An alternate purpose of these tests was to further investigate the importance of changes in fuel volatility over a wide range.

V. EXPERIMENTAL PROCEDURE

The fuel cart was completely drained of any fuel stored in it then filled with approximately 150 L of test fuel. The fuel was conditioned to a temperature of $19^{\circ}\text{C} \pm 1^{\circ}\text{C}$ and the fuel-dispense flow rate set to the desired value. The video recorder was positioned to capture the fuel sloshing during the filling of the fuel tank. Power was supplied to the purge cabinet and data acquisition equipment. A one litre glass jar was filled with a representative sample of the conditioned fuel according to ASTM D 5191 [8] procedures prior to the start of each test. The Reid-equivalent vapor pressure was determined for test trial using the MINIVAP VPS manufactured by Grabner Instruments (Vienna, Austria). The fuel-dispensing nozzle was placed into the filler pipe utilizing the locator pin from the fuel-dispensing nozzle fixture. The fuel-dispensing nozzle was triggered in order to dispense the fuel flow at the desired rate. The test proceeded until the fuel tank was filled or PSO occurred. In either case, the fill volume was recorded at the end of each fill. If PSO occurred, a time period of 10 seconds passed before attempting to fill again. This step was repeated several times. Fill volumes were recorded at each attempt. When the test was completed, the data acquisition was stopped and post comments recorded. The clear tube portion of the filler pipe was disconnected from the filler spud on the fuel tank. The vacuum line from the fuel-conditioning cart was then placed into the fuel tank, through the filter spud, and the tank completely drained.

A period of approximately twenty minutes elapsed before the next test was started. When the vent tube was required to be changed, the test would commence the next day due to the time required for the sealant to dry and to verify that no leaks existed.

VI. ANALYSIS OF EXPERIMENTAL RESULTS

Three quantities were varied during these experiments. They were the fuel Reid vapor pressure, RVP, the fuel-dispensing rate, Q_{Lin} , and the vent tube diameter, d_{vt} . The raw data consisted of tank dome and filler tube pressures versus time.

The analysis includes comparisons of the data to determine the influence of varying one experimental variable at a time while maintaining the remaining variables constant. For simplicity, only examples of the dimensional data are presented in the text to show the affects of the variables mentioned. The entire set of raw data is presented by Mastroianni [9]. Certain features of the raw data were then extracted and analyzed. In the following, it should be noted that the RVP values shown are actual measured RVP values although they will be referred to by their nominal values.

A. Variability of Pressure-time Data

In the case of NSO, the experiments were repeated three times for each set of experimental condition. Plotting all three data sets for each experimental condition on one graph indicates the variability in the results. For comparison purposes, the data for tank dome pressure and filler tube pressure are plotted in Fig. 8 and Fig. 9 respectively for one set of experimental conditions. Please note that the symbols in Fig. 8 and Fig. 9 are used for distinguishing the curves and reflect only a sampling of data points.

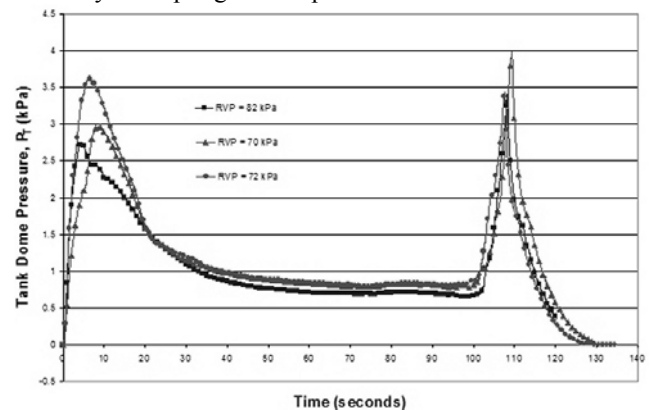

Fig. 8 Variability of tank dome pressure-time data for $d_{vt} = 9.5$ mm, $Q_{Lin} = 45$ L/min and nominal RVP = 83 kPa.

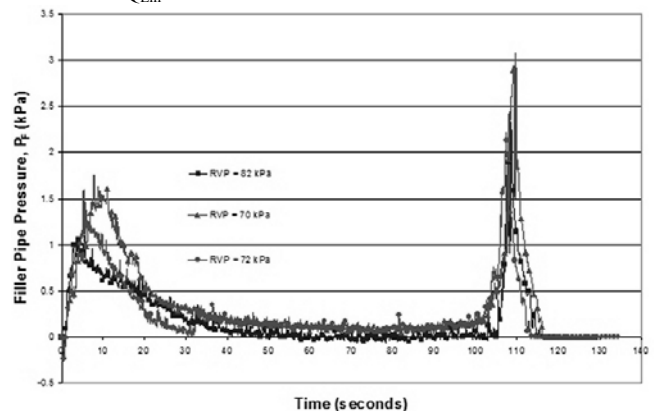

Fig. 9 Variability of filler pipe pressure-time data for $d_{vt} = 9.5$ mm, $Q_{Lin} = 45$ L/min and nominal RVP = 83 kPa.

Considerable variation is noticed from one test run to the next. This is primarily due to the difficulty experienced in maintaining the RVP at a constant value. The longer the fuel is left open to the atmosphere, the lower the value of the fuel RVP. For this reason the fuels are kept in sealed containers, however, the RVP still changed from one run to the next. From these plots the variation in the peak pressure during Phase I is approximately ± 0.5 kPa.

B. Pressure-time Data

Included in Fig. 10 are plots of the time history of the tank dome and filler pipe pressures with identical experimental conditions except for vent tube diameter. Note that the time scale in Fig. 10(c) is not the same as in Fig. 10(a) and Fig. 10(b). While maintaining the fuel-dispense rate constant at 45 L/min and the nominal RVP at approximately 55 kPa, it can

be seen that by reducing the inside diameter of the vent tube fitting, the tank dome and filler pipe pressure values increase. The pressure-time profiles in Figures 10(a) and 10(b) clearly demonstrate the existence of the three phases of refueling as reported by previous investigators and illustrated in Fig. 2. It is interesting to note that the Phase II portion of the pressure-time profile in Fig. 10(b) is of higher value as compared to Fig. 10(a).

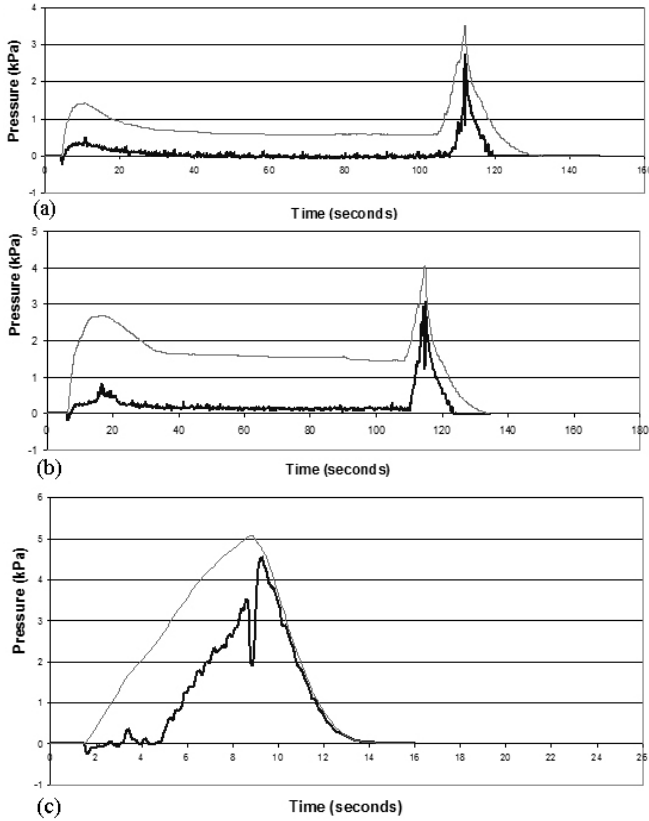

Fig. 10 Typical pressure-time history of the tank dome and filler pipe for the case where $Q_{Lin} = 45$ L/min and RVP = 55 kPa and (a) $d_{vt} = 9.5$ mm, (b) $d_{vt} = 6.4$ mm and (c) $d_{vt} = 3.2$ mm, (light line - tank dome pressure; dark line - filler pipe pressure).

The pressure-time profile in Fig. 10(c) clearly does not show the three phases of refueling. The 3.2 mm inside diameter vent tube caused PSO in all test combinations regardless of the fuel-dispensing rate and fuel RVP conditions including the calibration fluid which had a fuel RVP of approximately 7 kPa. Therefore, the pressure-time profile does not pass the Phase I portion of the expected three phases of refueling of a NSO pressure-time profile.

The filler pipe pressure-time profiles, shown in Fig. 10 have similar trends as the tank pressure profile albeit with more noise. With this fuel system, however, the filler pipe experiences lower pressures compared to the tank pressure and the Phase I peak is not as pronounced.

Plots similar to those in Fig. 10 are presented in Fig. 11 for the case of NSO, except that the fuel-dispense flow rate is larger while all other tank conditions are held constant. The pressure values in the tank and filler pipe are seen to increase

while increasing the fuel-dispense flow rate and maintaining the fuel RVP and the inside diameter of the vent tube constant.

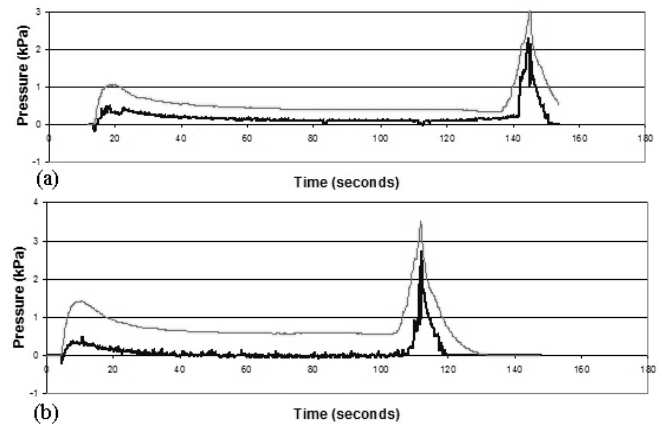

Fig. 11 Typical pressure-time history of the tank dome and filler pipe for the case where $d_{vt} = 9.5$ mm, RVP = 55 kPa and (a) $Q_{Lin} = 38$ L/min and (b) $Q_{Lin} = 45$ L/min (light line - tank dome pressure; dark line - filler pipe pressure).

The pressure-time histories for identical tank conditions as those in Fig. 11(b) are presented in Fig. 12 except for an increase in the RVP value. Increasing the fuel RVP has the effect of increasing the pressure values in the tank and filler, especially during the first peak.

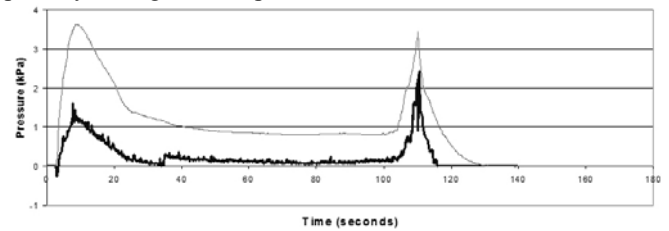

Fig. 12 Typical pressure-time history of the tank dome and filler pipe for the case where $d_{vt} = 9.5$ mm, $Q_{Lin} = 45$ L/min and RVP = 83 kPa (light line - tank dome pressure; dark line - filler pipe pressure)

The effect of decreasing the fuel RVP in the case where PSO occurs is presented in Fig. 13. As the RVP is decreased, the peak pressure at shut-off also decreased and the time to shut-off increased. However, it can be seen that the peak pressure at shut-off remains approximately constant for low values of fuel RVP and increases at higher fuel RVP. Although Fig. 13(c) indicates that fuel was dispensed for a longer period of time, it is still considered a PSO due to the fact that the fuel tank was not filled to the proper volume on its first attempt. Realistically, the fuel RVP used in actual vehicles will never be as low as the calibration fluid used in this experiment. It is, therefore, clearly seen that fuel evaporation is a factor (up to a point) in determining the pressure in the tank and causing PSO to occur in a shorter period of time.

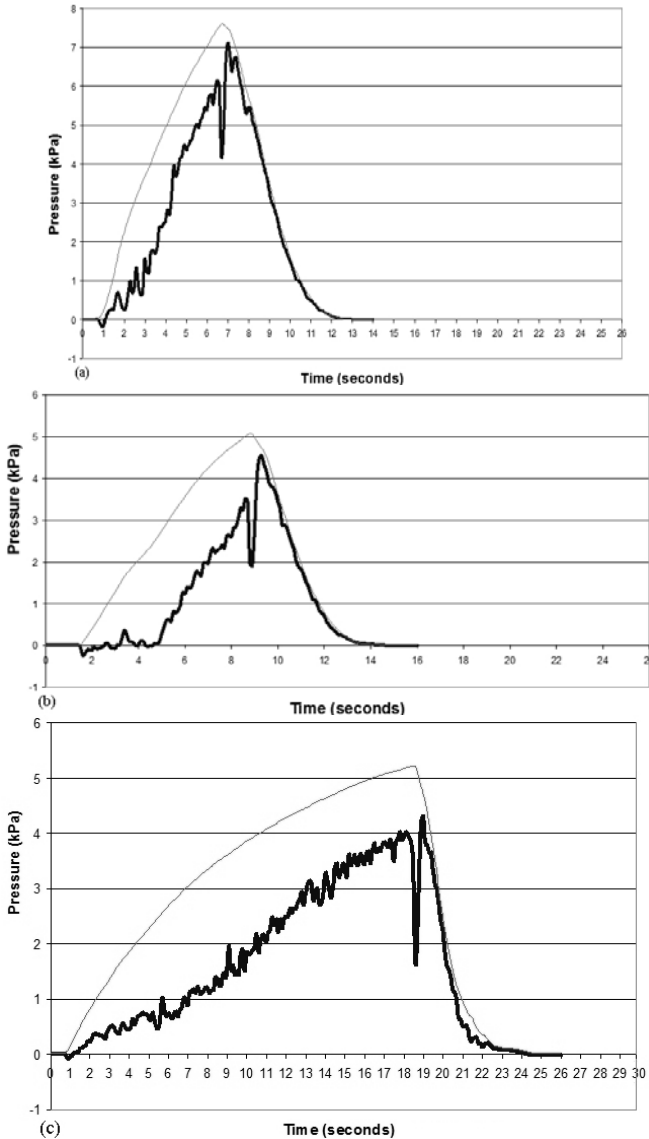

Fig. 13 Typical pressure-time history of the tank dome and filler pipe for the case where $d_{vt} = 3.2$ mm, $Q_{Lin} = 45$ L/min with (a) RVP = 83, (b) RVP = 55 kPa and (c) RVP = 7 (light line - tank dome pressure; dark line - filler pipe pressure)

Pressure-time histories where PSO occurred for identical tank conditions but different flow rates are given in Fig. 14. Comparisons indicate that by increasing the fuel-dispense flow rate, the tank and filler pipe pressure increases while the time to shut-off decreases. Obviously, more fuel is initially forced into the tank in the case of the higher fuel-dispensing flow rate, and this leads to a faster build-up in pressure and a more rapid occurrence of PSO.

Spill-back was expected and did occur at the end of each and every refueling test. This can be explained by looking at the pressure-time profile for the filler pipe pressure (PF).

Fig. 15 highlights the area where spill occurred. It can be seen that the filler pipe pressure experienced a quick drop (Point 1 to Point 2) followed with a sudden increase in pressure (Point 2 to Point 3). This was due to the fuel-dispensing nozzle being deactivated at Point 1, which caused

the filler pipe pressure to decrease to Point 2 due to the momentum of the slug of fuel travelling through the filler pipe. The slug is decelerated due to the higher pressure in the tank, and the lower pressure upstream in the filler pipe. From Point 2 to Point 3 the fuel slug is accelerated up the filler pipe causing an increase in pressure and the liquid fuel to exit from the filler pipe. To prevent this, practical fuel systems employ a check valve at the location where the filler pipe connects to the fuel tank.

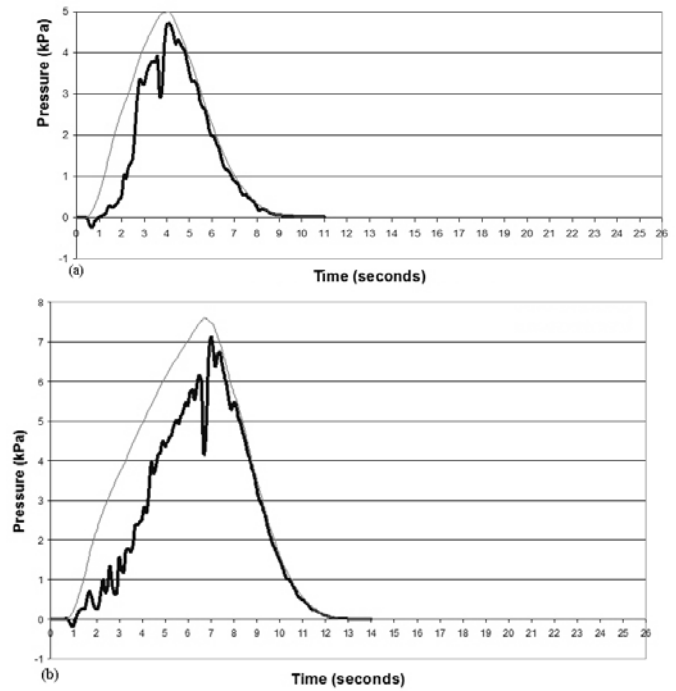

Fig. 14 Typical pressure-time history of the tank dome and filler pipe for the case where $d_{vt} = 3.2$ mm, RVP = 83 with (a) $Q_{Lin} = 38$ L/min and (b) $Q_{Lin} = 45$ L/min (light line - tank dome pressure; dark line - filler pipe pressure)

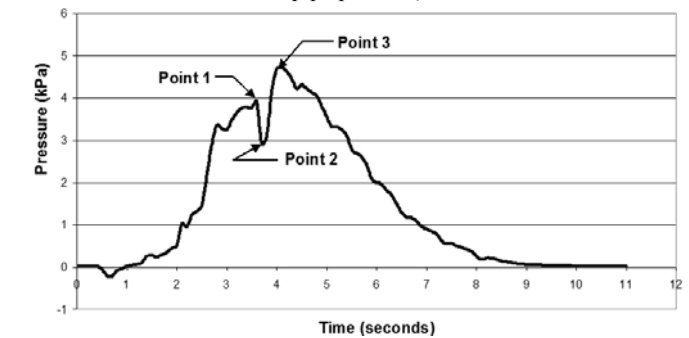

Fig. 15 Typical pressure-time history of the filler pipe highlighting the sequence for spill-back where $d_{vt} = 32.5$ mm, $Q_{Lin} = 38$ L/min and RVP = 83 kPa

C. Peak Pressure Data in Phase I

The peak tank dome pressures in Phase I were extracted from the pressure-time curves and are presented for comparison in Fig. 16 plotted against the area of the vent tube. Each data point is the average of three tests with the same conditions. The RVP values shown are nominal values. In the case where PSO occurred (lowest vent-tube area) the peak pressure at PSO was taken. Therefore, the peak pressures at

which PSO occurred are compared with the peak pressures of the Phase I region where NSO occurred.

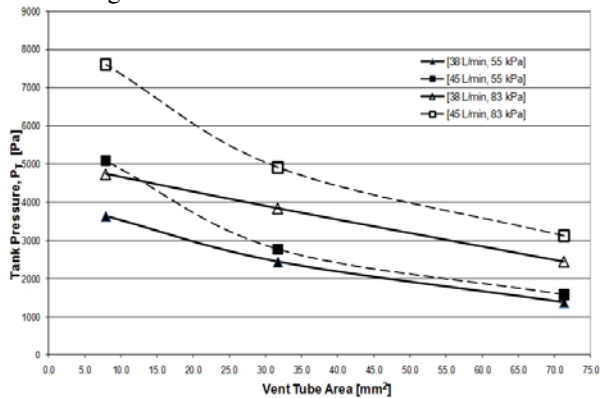

Fig. 16 Average peak tank dome pressures during Phase I versus the area of the vent tube

On a relative basis for the case of NSO, the increase in tank dome pressure due to an increase in RVP is equal or greater than the increase in tank dome pressure due to an increase in Q_{Lin} . For the case of PSO, the trend is reversed. On a relative basis for all shut-off types, the sensitivity of tank dome pressure to RVP increases with increasing fuel-dispensing rate. In addition, Fig. 16 shows that the peak pressures under PSO conditions (8 mm² vent tube area) can be less than the Phase I peak pressures under NSO conditions (≥ 32 mm² vent tube area).

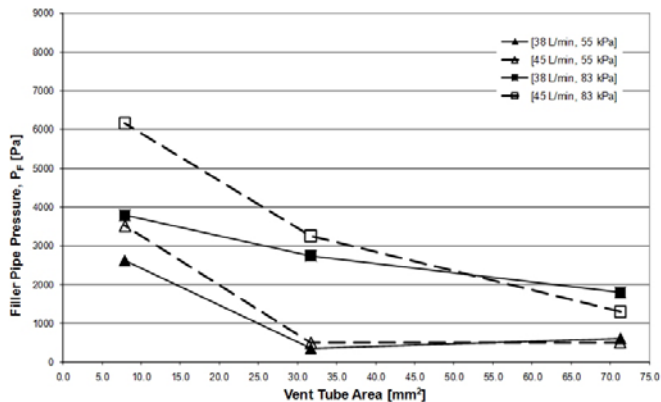

Fig. 17 Average peak filler pipe pressures during Phase I versus area of the vent tube

The curves in Fig. 17 are similar to those of Fig. 16, except that the pressure values are recorded within the filler pipe. Similar observations to those made in Fig. 16 can be seen here except in the region where the vent tube area is approximately between 35 mm² and 72 mm². It can be seen that at a vent tube area of approximately 52 mm², the curves which have a fuel-dispense rate at 45 L/min intersect the curve which have a lower fuel-dispense rate. It is reasonable to expect this to occur because at the higher flow rate, an increase in the velocity would be expected in the upper region of the filler pipe. This increased velocity would result in a decrease in pressure due to the Bernoulli effect and the fact that the

entrance pressure is atmospheric. At smaller vent tube areas the flow in the vent tube is restricted, lowering the velocity and resulting Bernoulli effect.

VII. CONCLUSIONS

The inside diameter of the vent tube is a critical parameter in causing premature shut-off. A higher fuel RVP and fuel-dispense rate resulted in higher tank dome pressures, but not necessarily a premature shut-off. On a relative basis, the fuel RVP is more effective in increasing the tank dome pressure than an increase in the fuel-dispense rate. In the cases of both premature shut-off and normal shut-off, a sharp decrease in the filler pipe pressure followed by a large pressure rise to a value greater than before the drop was noted at shut-off. In the cases of both premature shut-off and normal shut-off, a sharp decrease in the filler pipe pressure followed by a large pressure rise to a value greater than before the drop was noted at shut-off.

ACKNOWLEDGMENT

The authors would like to acknowledge the financial support provided by Kautex Textron and the Natural Sciences and Engineering Research Council of Canada through Collaborative Research Development Grant, Number CRD 227033/99.

REFERENCES

- [1] S. Stoneman, "On the design of automotive fuel filler pipes," *Automotive Engineer*, vol. 22, no. 1, Feb. 1997, pp. 32-36.
- [2] D. H. Frobese, "Pressure and Flow Rates Occurring In Road-Tanker/Petrol-Station Systems During the Delivery of Petrol," *Journal of Hazardous Materials*, vol. 62, no. 2, 1998, pp. 199-210.
- [3] T. K. Garrett, *Automotive Fuels and Fuel Systems, Volume 1: Gasoline*, Society of Automotive Engineers, Inc., Warrendale, PA, 1991.
- [4] N. Sinha, R. Thompson and M. Harrigan, *Computational Simulation of Fuel Shut-Off During Refueling*, SAE Paper 981377, Society of Automotive Engineers, Inc., Warrendale, PA, May 1998.
- [5] M. Holloway, "Fill 'Er Up," *Scientific American*, New York, NY, May 2000, pp. 92-93.
- [6] National Instruments™, *The Measurement and Automation Catalog 2000*, National Instruments™ Corporation, Austin Texas.
- [7] ASTM Standard D 5191, *Standard Test Method for Vapor Pressure of Petroleum Products (Mini Method)*, 1996 Annual Books of ASTM Standards, American Society for Testing and Materials, West Conshohocken, PA.
- [8] G. O. Young, "Synthetic structure of industrial plastics (Book style with paper title and editor)," in *Plastics*, 2nd ed. vol. 3, J. Peters, Ed. New York: McGraw-Hill, 1964, pp. 15-64. W.-K. Chen, *Linear Networks and Systems* (Book style). Belmont, CA: Wadsworth, 1993, pp. 123-135.
- [9] Mastroianni, M., *Experimental Investigation of Automotive Fuel Tank Filling*, M.A.Sc. Thesis, Mech., Auto. and Mat'ls Eng. Dept., University of Windsor, Windsor, ON, Canada, 2000.