

Analytical Cutting Forces Model of Helical Milling Operations

Changyi Liu, Gui Wang, and Matthew Dargusch

Abstract—Helical milling operations are used to generate or enlarge boreholes by means of a milling tool. The bore diameter can be adjusted through the diameter of the helical path. The kinematics of helical milling on a three axis machine tool is analysed firstly. The relationships between processing parameters, cutting tool geometry characters with machined hole feature are formulated. The feed motion of the cutting tool has been decomposed to plane circular feed and axial linear motion. In this paper, the time varying cutting forces acted on the side cutting edges and end cutting edges of the flat end cylinder miller is analysed using a discrete method separately. These two components then are combined to produce the cutting force model considering the complicated interaction between the cutters and workpiece. The time varying cutting force model describes the instantaneous cutting force during processing. This model could be used to predict cutting force, calculate static deflection of cutter and workpiece, and also could be the foundation of dynamics model and predicting chatter limitation of the helical milling operations.

Keywords—Helical milling, Hole machining, Cutting force, Analytical model, Time domain

I. INTRODUCTION

HELICAL milling has been applied to generate boreholes by means of a milling tool to some difficult to cut materials. This innovative method was found to facilitate hole-making in AISI D2 tool steel in its hardened state, resulting in an enhancement in cutting tool life, and the ability to machine H7 quality holes with a surface finish of $0.3 \mu\text{m Ra}$ [1]. The operation has also been applied to hole making in composite-metal compounds as a substitute for drilling operations. The influence of axial and tangential feed on the bore hole diameter during helical milling was investigated in this paper. The impact of the axial and tangential feed per tooth on the process forces [2] has also been investigated. Employing helical milling to Aluminium with MQL has shown in improvement in geometrical accuracy and a reduction in burr formation and lower cutting temperature and a smaller cutting force comparing to drilling operations [3].

To a certain machining operation, whether it is available to a

certain component fabrication is decided not only by the efficiency and cost, but by the ability to satisfy the needed accuracy and precision of the manufactured product, etc. As milling is almost the most complex machining operation, the machining mechanisms associated were derived from a general model [4] and applied to the specific application, for example, plunge milling. The intersection of the tool path swept envelope (SWE) with the workpiece Z-buffer elements (ZDVs) were used to find the contact area between the cutter and the workpiece. An axial slice cutting tool axial discrete mechanistic model was used to estimate the cutting force vectors [5]. The effect of lead and tilt angles between the cutter and the workpiece to the milling forces, tool deflections and form errors for 5-axis ball-end milling were analyzed [6].

As a type of 3-axis milling operation, axial feed is a typical characteristic of helical milling operations. One of the different behaviours of cutting forces between 3-axis and x-y 2-axis milling should be the cutting forces derived from axial feed during 3-axis milling. Considering rigid body motion of the cutter, the cutting force model for the plunge milling process in the time domain was established [7, 8]. The cutting forces of plunge milling operations are predicted by considering the feed, radial engagement, tool geometry, spindle speed, and the regeneration of the chip load due to vibrations [9].

The drilling operations have the axial feed typically, that is similar to the helical milling and plunge milling operations but different cutting tools. Drilling cutting forces and dynamics model were established and integrated in order to obtain drilled hole profiles [10]. 3D mechanistic cutting force models used to predict lateral forces, torque and thrust as functions of feedrate, radial depth of cut, drill geometry and vibrations were setup [11]. To analytical model to predict temperatures and forces on both the drilling and ball end milling operations, the cutting edges of the twist drill lip and the ball end mill were divided into oblique cutting elements [12]. A theoretical model to predict thrust and torque in high speed drilling was presented [13]. Methodology for extracting cutting force coefficients of drilling operations also was investigated [14]. During modelling cutting forces of drilling, the axial feed was not considered, the reason is that the lip of twist drill has a taper angle (point angle), the interaction between the lip and workpiece caused by spindle rotation would lead to the axial force (thrust) spontaneously.

However, the published research for the helical milling process is limited to an enabling technology in order to substitute drilling operations [1-3]. The research on the mechanics and force model about the helical milling process has not yet been found. This research aims to build up the analytical

Changyi Liu is with the Nanjing University of Aeronautics & Astronautics, and visiting academic with the University of Queensland, Brisbane, QLD 4072 Australia (phone: 617-3346-9215; fax: 303-3365-3888; e-mail: changyi.liu@uq.edu.au).

Gui Wang is with the CAST CRC, School of Mechanical and Mining Engineering, the University of Queensland, Brisbane, QLD 4072 Australia (phone: 617-3346-9215; fax: 303-3365-3888; e-mail: gui.wang@uq.edu.au).

Matthew Dargusch is with the CAST CRC, School of Mechanical and Mining Engineering, the University of Queensland, Brisbane, QLD 4072 Australia (phone: 617-3346-9225; fax: 303-3365-3888; e-mail: m.dargusch@cast.org.au).

cutting force model in the time domain associated with helical milling operations for two main applications – hole generation and hole enlargement. The model will consider the effects of the tangential feed and axial feed, and the combination of both instantaneous cutting forces on the side cutting edge and the end cutting edge.

II. KINEMATICS OF HELICAL MILLING

In helical milling, the trajectory of a point on the milling tool cutting edge is the result of the spiral curve movement of the axis of the tool (reference frame) and the circular movement of the edge point relative to the axis (relative motion). The diameter of the bore Φ_B and the endmill diameter D_m , the rotating angular velocity Ω_h of the helix feed, the axial feed f_{va} and the tangential feed f_{vt} , and the spindle rotational velocity Ω , depicted in Fig. 1.

Two sets of coordinates are used to describe the motion of the cutter and the cutting force on the cutter. An X, Y, Z world coordinate system (WCS) fixed to the workpiece. A x, y, z local coordinate system (LCS) fixed to the cutting tool with the origin at the centre of the end flat surface, being the reference frame.

The feed motion of tool is decomposed to two components, the axial feed f_{va} and the tangential feed f_{vt} ,

$$f_{vt} = (\Phi_B - D_m)\Omega_h / 2 = N_m \Omega f_{zt} / 60 (mm/s) \tag{1}$$

$$f_{va} = P\Omega_h / 2\pi = N_m \Omega f_{za} / 60 (mm/s) \tag{2}$$

where, N_m is the flute number of the endmill, f_{zt} is the tangential feed per tooth per round, f_{za} is the axial feed per tooth per round, P is the pitch of the helix curve of the reference frame.

The flat-end cylinder milling tools suitable for helical milling operations have two types of cutting edges: the side cutting edge (peripheral cutting edge), and the end cutting edge (end cutting edge). The interaction characteristics of these two types with the workpiece are different. The side edges participate in the peripheral cutting component, while the end edges participate in the plunge cutting component. Therefore, these two movements will be initially analysed separately before being assembled or composed.

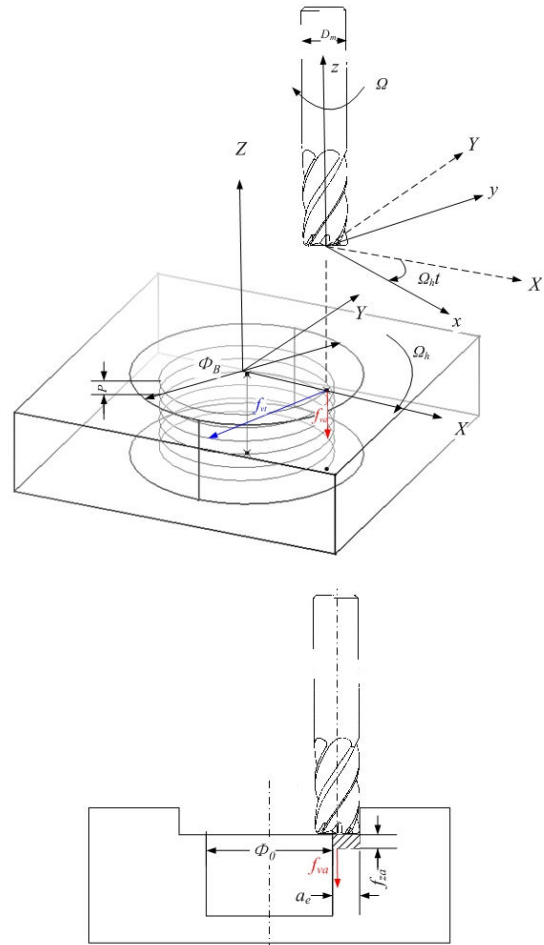

Fig. 1 Kinemics of helical milling

The side edge cutting process is typical intermittent cutting. The undeformed chip geometry, width, depth, and thickness can be described in the literature [2]. Considering the side edge cutting process, that is typical intermittent cutting, depicted in Fig. 2 (using superscript i). The undeformed chip geometry, width, depth, and thickness can be described as

$$a_e^i = \begin{cases} D_m, & \text{hole-generating} \\ \Phi_B - \Phi_O / 2, & \text{hole-enlarging} \end{cases} \tag{3}$$

$$a_p^i(t) = \begin{cases} f_{va}t, & t \leq 2\pi / \Omega_h \\ P, & t > 2\pi / \Omega_h \end{cases} \tag{4}$$

$$h^i = f_{zt} \sin \phi \tag{5}$$

where, $\phi = 2\pi(\Omega \pm \Omega_h)t$ is the relative rotational angle of the cutter (+ up milling, - down milling).

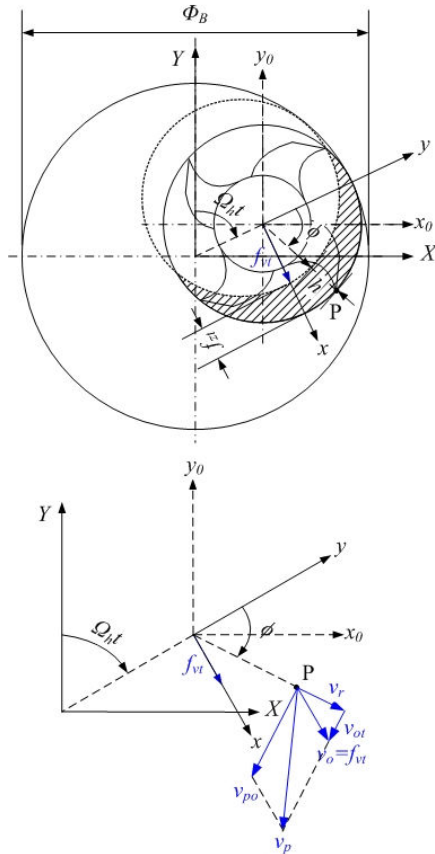

Fig. 2 Kinematics of the side cutting edge

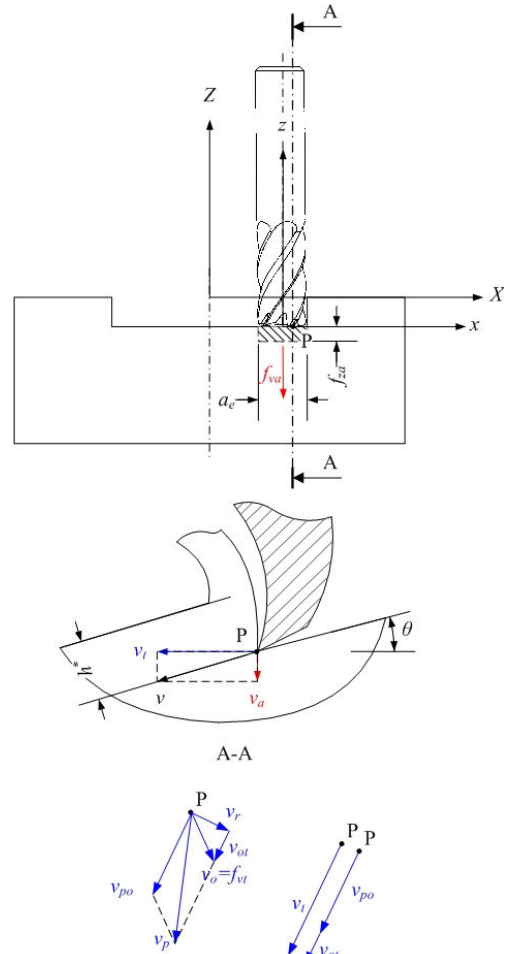

Fig. 3 Kinematics of the end cutting edge

Considering the end edge cutting process, it is continuous cutting, depicted in Fig. 3 (using superscript *). The undeformed chip geometry, width and height can be described as:

$$h^* = f_{za} \cos \theta \quad (6)$$

$$a_e^* = \begin{cases} D_m, & \text{hole-making} \\ \Phi_B - \Phi_O/2, & \text{hole-enlargeing} \end{cases} \quad (7)$$

III. CUTTING FORCE MODEL FOR HELICAL MILLING

Based on the kinematics of helical milling process, two new features that could influence the cutting force and dynamics of the helical milling process were considered. One was the periodical force variation created by the circle or tangential feed of the tool, the other is the additional force component generated by the axial feed of the tools. The axial feed force mostly occurred at the end cutting edge (end cutting edge) of the milling tools. The interaction condition between the tool and the workpiece is the combination of side edge cutting forces and end edge cutting forces.

$$\vec{F} = \vec{F}^i + \vec{F}^* \quad (8)$$

Where, \vec{F}^i is the side cutting edge component and \vec{F}^* is end cutting edge component. Considering a point P on the (jth) cutting tooth, shown in Fig. 4, the integration cutting force \vec{F}^i (defined in the LCS) along the in-cut portion of the flute j is similar to that presented in the referenced literature [4], as

$$F^i_{x,j}(\phi_j(z)) = \left\{ \begin{aligned} & \frac{f_{zt}}{4k_\beta} \left[-K_{tc} \cos 2\phi_j(z) + K_{rc} \begin{pmatrix} 2\phi_j(z) \\ -\sin 2\phi_j(z) \end{pmatrix} \right] \\ & + \frac{I}{k_\beta} [K_{te} \sin \phi_j(z) - K_{re} \cos \phi_j(z)] \end{aligned} \right\}_{\phi_{j,z}(\varepsilon_{j,1})}^{\phi_{j,z}(\varepsilon_{j,1})} \quad (9)$$

$$F^i_{y,j}(\phi_j(z)) = \left\{ \begin{aligned} & \frac{-f_{zt}}{4k_\beta} \left[K_{tc} (2\phi_j(z) - \sin 2\phi_j(z)) \right] \\ & + \frac{I}{k_\beta} [K_{re} \cos \phi_j(z) + K_{te} \sin \phi_j(z)] \end{aligned} \right\}_{\phi_{j,z}(\varepsilon_{j,1})}^{\phi_{j,z}(\varepsilon_{j,1})} \quad (10)$$

$$F^i_{z,j}(\phi_j(z)) = \frac{I}{k_\beta} [K_{ac} f_{zt} \cos \phi_j(z) + K_{ae} \phi_j(z)]_{\phi_{j,z}(\varepsilon_{j,1})}^{\phi_{j,z}(\varepsilon_{j,1})} \quad (11)$$

where $k_\beta = 2 \tan \beta / D_m$, β is helix angle of the cutter, ϕ_j is the rotational angle of the tooth j, and K_{rc} , K_{tc} , K_{ac} , K_{re} , K_{te} , K_{ae}

are the cutting force coefficients and edge force coefficients (on side cutting edges) respectively.

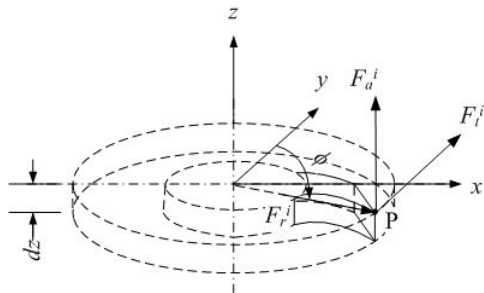

Fig. 4 Cutting forces on the side cutting edge

As the tangential feed f_{vt} and axial feed f_{va} are presented during the helical milling, during analysis the end cutting edge force component, the edge of these teeth are assumed to be a straight line and coincide with the radial line; neglecting the friction force along the end cutting edge. Therefore, the radial force $F_a^* = 0$. As shown in Fig. 5, the end cutting edge force component can be formulated as

$$dF_v^* = K_{vc}^* f_{za} \cos \theta dr + K_{ve}^* dr \quad (12)$$

$$dF_n^* = K_{nc}^* f_{za} \cos dr + K_{ne}^* dr \quad (13)$$

$$dF_t^* = dF_v^* \cos \theta - dF_n^* \sin \theta \quad (14)$$

$$dF_a^* = dF_v^* \sin \theta + dF_n^* \cos \theta \quad (15)$$

$$dT_j^* = r dF_t^* \quad (16)$$

where K_{vc}^* , K_{ve}^* is the cutting force coefficient on the end cutting edges.

$$\text{Denote } A = \frac{N_m f_{za}}{2\pi}, \quad B = \frac{N_m f_{zt} \cos \phi_j}{2\pi},$$

$$\theta = \arg \tan \frac{v_a}{v_t} = \arg \tan \frac{A}{r+B}, \quad [K^*] = \begin{bmatrix} K_{vc}^* & K_{ve}^* \\ K_{nc}^* & K_{ne}^* \\ K_{rc}^* & K_{re}^* \end{bmatrix},$$

$$[\Theta] = \int_{\frac{D_m}{2} - a_c}^{\frac{D_m}{2}} dr \begin{bmatrix} \cos \theta & -\sin \theta & 0 \\ \sin \theta & \cos \theta & 0 \\ 0 & 0 & 0 \\ r \cos \theta & -r \sin \theta & 0 \end{bmatrix}, \text{ therefore,}$$

$$\begin{bmatrix} F_{t,j}^* \\ F_{a,j}^* \\ F_{r,j}^* \\ T_j^* \end{bmatrix} = [\Theta][K^*] \begin{bmatrix} f_{za} \\ 1 \end{bmatrix} \quad (17)$$

Transform to the LCS coordinate,

$$\therefore \begin{bmatrix} F_{x,j}^* \\ F_{y,j}^* \\ F_{z,j}^* \\ T_j^* \end{bmatrix} = \begin{bmatrix} -F_{t,j}^* \cos(\phi_j(t)) \\ F_{t,j}^* \sin(\phi_j(t)) \\ F_{a,j}^* \\ T_j^* \end{bmatrix} \quad (18)$$

Sum up side cutting edge forces and end cutting forces on the j th tooth, and convert to the WCS coordinate.

$$\begin{bmatrix} F_{X,j} \\ F_{Y,j} \\ F_{Z,j} \\ T_{Z,j} \end{bmatrix} = \begin{bmatrix} \cos \Omega_h t & \sin \Omega_h t & 0 & 0 \\ -\sin \Omega_h t & \cos \Omega_h t & 0 & 0 \\ 0 & 0 & 1 & 0 \\ 0 & 0 & 0 & 1 \end{bmatrix} \begin{bmatrix} F_{x,j}^i + F_{x,j}^* \\ F_{y,j}^i + F_{y,j}^* \\ F_{z,j}^i + F_{z,j}^* \\ T_j^* \end{bmatrix} \quad (19)$$

Then, sum up all the cutting forces on the cutting teeth; get the cutting forces model.

$$\begin{bmatrix} F_X \\ F_Y \\ F_Z \\ T_Z \end{bmatrix} = \sum_{j=1}^{N_n} \begin{bmatrix} F_{X,j} \left(\Omega t + (j-1) \frac{2\pi}{N} \right) \\ F_{Y,j} \left(\Omega t + (j-1) \frac{2\pi}{N} \right) \\ F_{Z,j} \left(\Omega t + (j-1) \frac{2\pi}{N} \right) \\ T_{Z,j} \left(\Omega t + (j-1) \frac{2\pi}{N} \right) \end{bmatrix} \quad (20)$$

The cutting forces model during helical milling operations in the time domain has therefore been established analytically. This model defines both the cutting force on the primary cutting edge and on the secondary cutting edge, incorporating the interactions between the cutter and the workpiece on the effect of the spindle rotation and the tangential feed. The effect of axial feed during helical milling has also been incorporated.

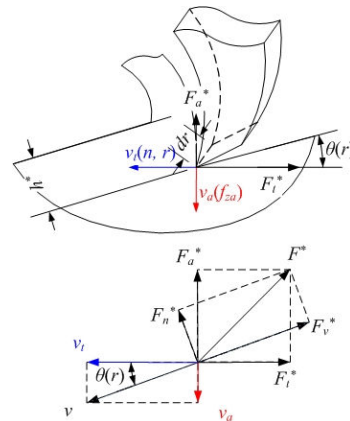

Fig. 5 cutting forces on the end cutting edge

IV. SIMULATIONS AND EXPERIMENTAL RESULTS

The cutting forces and dynamics models of helical milling are simulated with MATLAB programme; and experiments relative to the model and simulation are designed and carried out. The titanium alloy ZTC4 (Casting Ti6Al4V) workpiece blank are casted and then semi-finished to the shape as Fig. 1 shown, initial diameter 60mm, height 20mm, length and width 160mm respectively. Cutting tools are M.A. Ford 5-flute carbide end mill 16 mm 5-flute carbide end mill (17862903A).

Three The tangential feed rate of f_{zt} have three levels, that is 0.06mm/(tooth /rev), 0.075mm, 0.09mm; the axial feed rate of f_{za} have three levels, that is 0.48 mm/(tooth /rev), 0.60mm, 0.72 mm; the radial cutting depth of a_e and spindle velocity Ω have three levels respectively. Experiments were carried out at a five-axis high speed Mikron UCP-710 CNC machining centre. A three axis piezo-electric dynameter Kistler 9265B type was

setup on the fixture with the workpiece. The accessory data acquisition system of the dynameter consisted of Kistler 5019A type multi-channel charge amplifier, and cutting forces signal processing software DynoWare.

V. CONCLUSION

A force model based on discretisation of the cutting edge has been established. This model expresses the detail of the cutting process instantaneously. The integration of the discrete elements provides the global effect of the forces. The complicated cutting process has been decomposed into two

components: side cutting edge forces and end cutting edge forces. As a result, this model can describe both the global force effects and the time varying effects. The characteristics of the frequency of the cutting force are also included in the model including the spindle rotational velocity Ω_h , the helical feed rotational velocity Ω , and their lag $\Omega - \Omega_h$. The cutting force model can be used to calculate the tool and workpiece deflection during the cutting process or to build a dynamics model and predict the chatter free limitations of the helical milling operations.

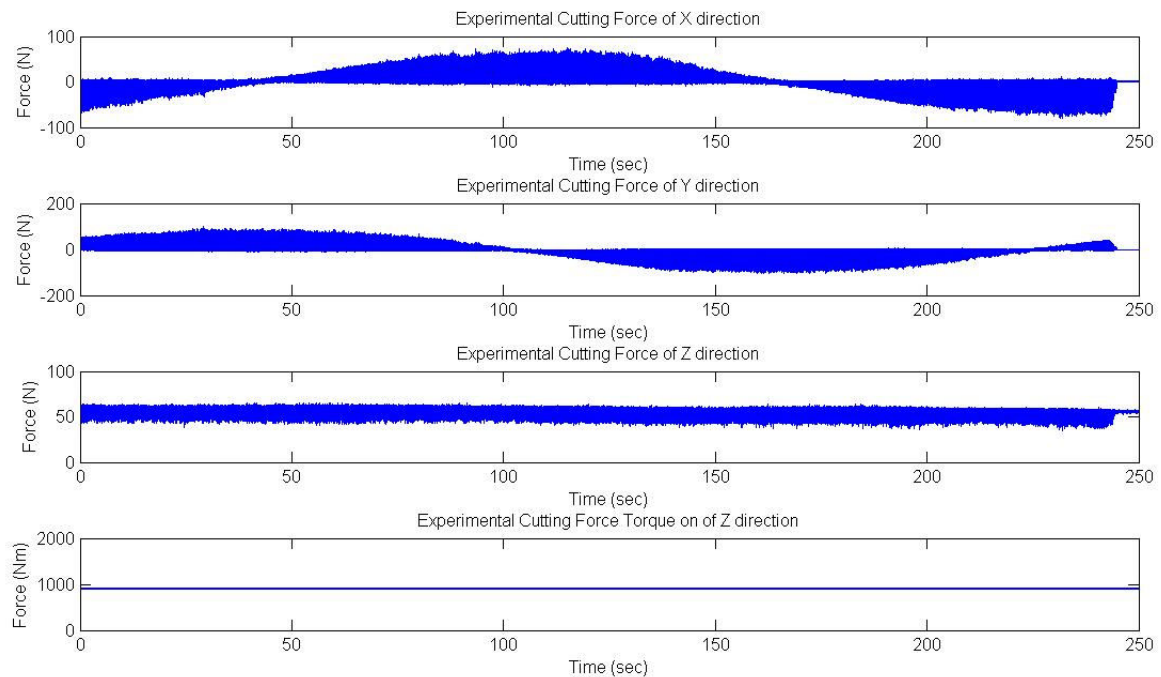

(a) Experiment cutting forces

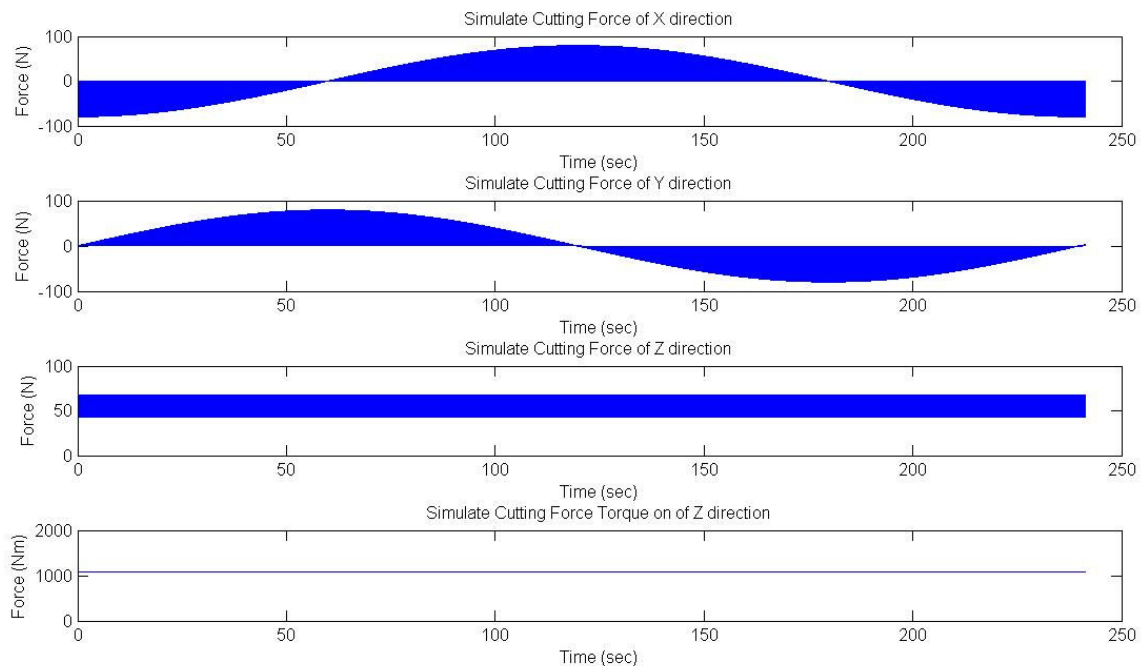

(b) Simulation cutting forces

Fig. 6 Experiment and Simulation of the Helical milling Cutting forces results
(Cutting speed v_c 100m/min, axial feed rate f_{za} 0.5 mm/tooth/rev, tangential feed rate f_{zt} 0.1 mm/tooth/rev)

REFERENCES

- [1] R. Iyer, P. Koshy, and E. Ng, "Helical milling: An enabling technology for hard machining precision holes in AISI D2 tool steel," *International Journal of Machine Tools & Manufacture*, vol. 47, no. 2, pp. 205-210, Feb. 2007.
- [2] B. Denkena, D. Boehnke, and J.H. Dege, "Helical milling of CFRP-titanium layer compounds," *CIRP Journal of Manufacturing Science and Technology*, vol. 1, no. 2, pp. 64-69, Mar. 2008.
- [3] H. Sasahara, M. Kawasaki, and M. Tsutsumi, "Helical Feed Milling with MQL for Boring of Aluminum Alloy," *Transactions of the Japan Society of Mechanical Engineer, Part C*, vol. 69, no. 8, pp. 2156-2161, Aug. 2003.
- [4] Y. Altintas, *Manufacturing Automation: Principles of Metal Cutting and machine Tool Vibrations* (Book style). New York, US: Cambridge University Press, 2000, pp. 41-46.
- [5] B.K. Fussell, R.B. Jerard, and J.G. Hemmett, "Modeling of cutting geometry and forces for 5-axis sculptured surface machining," *Computer-Aided Design*, vol. 35, no. 4, pp. 333-346, Mar. 2003.
- [6] E. Ozturk, and E. Budak, "Modeling of 5-axis milling processes," *Machining Science and Technology: An International Journal*, vol. 11, no. 3, pp. 287 - 311, Feb. 2007.
- [7] Y. Altintas, and J.H. Ko, "Chatter stability of plunge milling," *CIRP Annals-Manufacturing Technology*, vol. 55, no. 1, pp. 361-364, Jan. 2006.
- [8] J.H. Ko, and Y. Altintas, "Dynamics and stability of plunge milling operations," *Journal of Manufacturing Science and Engineering-Transactions of the ASME*, vol. 129, no. 1, pp. 32-40, Jan. 2007.
- [9] J.H. Ko, and Y. Altintas, "Time domain model of plunge milling operation," *International Journal of Machine Tools & Manufacture*, vol. 47, no. 9, pp. 1351-1361, Jul. 2007.
- [10] M. Pirtini, and I. Lazoglu, "Forces and hole quality in drilling," *International Journal of Machine Tools & Manufacture*, vol. 45, no. 11, pp. 1271-1281, Sep. 2005.
- [11] J.C. Roukema, and Y. Altintas, "Generalized modeling of drilling vibrations. Part I: Time domain model of drilling kinematics, dynamics and hole formation," *International Journal of Machine Tools & Manufacture*, vol. 47, no. 9, pp. 1455-1473, Aug. 2007.
- [12] M. Shatla, and T. Altan, "Analytical modeling of drilling and ball end milling," *Journal of Materials Processing Technology*, vol. 98, no. 1, pp. 125-133, Jan. 2000.
- [13] M. Elhachimi, S. Torbaty, and P. Joyot, "Mechanical modelling of high speed drilling. I: predicting torque and thrust," *International Journal of Machine Tools & Manufacture*, vol. 39, no. 4, pp. 553-568, Mar. 1999.
- [14] R.F. Hamade, C.Y. Seif, and F. Ismail, "Extracting cutting force coefficients from drilling experiments," *International Journal of Machine Tools & Manufacture*, vol. 46, no. 3-4, pp. 387-396, Apr. 2006.

Changyi Liu was born in 1973 at Xi'an, China. He received his Bachelor degree in Mechanical Engineering in 1996 and PhD in Mechanical Engineering in 2001 from the Nanjing University of Science and Technology, Nanjing, China. His major research field includes mechanical product design, and manufacturing process model, simulation and planning.

He joined Nanjing University of Aeronautics & Astronautics, Nanjing, China, in 2001 and now is an associate professor of mechanical engineering. From March 2011, he is working as a visiting academic at the University of Queensland, Brisbane, Australia.