

Using Finite Element Method for Determination of Poles Number in Optimal Design of Linear Motor

Abdolamir Nekoubin

Abstract—one of Effective parameters on the performance of linear induction motors is number of poles which must be selected and optimized to increase power efficiency and motor performance significantly. In this paper a double-sided linear induction motor with different poles number by using MAXWELL3D software is designed and with finite element method is analyzed electromagnetically. Then for dynamic simulation, linear motor by using MATLAB software is simulated. The results show that by adding poles number, system time response is increased and motor after more time reaches to steady state. Also propulsion force of motor is increased.

Keywords—Linear Motor, Poles Number, Finite Element Method

I. INTRODUCTION

THE linear electric motors can be classified into following: DC motors, induction motors, synchronous motors and stepping motors etc. Among these, the linear induction motor (LIM) has many advantages such as reduction of mechanical losses and the size of motion devices, silence, high starting thrust force, and easy maintenance, repairing, and replacement [1]-[2]. Linear motors are electrical machines which unlike normal machines do not have rotors in the traditional sense, but elements which move in a straight line when the machine is excited. In a normal three phase induction motor, the stator produces a rotating magnetic field which induces the rotor to rotate along with it. One may consider the Linear Induction Motor (LIM) to be constructed out of its rotary counterpart where the stator and the rotor have been cut and unrolled. Now, the stator produces a traveling magnetic field instead of a rotating one. The rotor is induced to move along it. The exciting element of the LIM (like the stator in the normal rotary machine) is called the primary and the element in which currents are induced (like the rotor in the normal rotary machine) is called the secondary of the LIM. Usually either of the primary or the secondary is stationary and extends over the entire range of motion of the other element. Thus, LIMs may be classified as either short-primary (also called short-stator in literature) or short-secondary (called short-rotor) LIMs. LIMs may also be classified based on its construction as primary and one secondary placed one on top of the other, Double Sided LIM (DLIM) in which there are two primaries on the two sides of a secondary. They are also classified as high-speed and low-speed LIMs [3]-[4]. The

basic difference in the analysis of the rotary induction motor and the LIM lies in the open air gap of the LIM due to the finite length and width of the elements of the LIM. These cause pronounced 'distortions' called longitudinal and transverse end effects (due to the finite length and width respectively). It has been shown in [5] that the longitudinal end effect degrades the performance and brings to question the very feasibility of the use of LIMs. Also, the air gaps in LIMs are usually of higher magnitude than those in normal induction motors. The product of efficiency and power factor in a LIM usually does not exceed 0.5, whereas rotary induction motors with power factor= 0.8 have been designed. The reason why linear motors are preferred over normal motors for high speed propulsion is the fact that rotary motor propulsion depends on friction and is limited by the maximum achievable friction. The linear motor obtains its thrust from the traveling magnetic field, and thus, there is no theoretical limit to the maximum thrust achievable. This results in faster accelerations and higher speeds. Linear motors suggest themselves in low speed applications too where gearing mechanisms are preferably avoided. References [6]-[11] propose some methods on the study of SLIM performance. Fourier Transformation Technique, Space Harmonic Method and Winding Function Method are often used to analysis and design of SLIM from a macroscopic standpoint. However, it is difficult to calculate the distribution of the flux density, the eddy current density and force density in whole region of SLIM with the speed rising. The FEM electromagnetic analysis model is developed to analyze SLIM in inverter-driven variable speed systems and a novel stator core structure by parametric analysis is proposed in this paper. The interpolation movement interface method is used to solve the transient electromagnetic field-circuit-torque coupling problem. The paper focuses on the dynamic characteristics analysis of SLIM whole operation process with different frequency using FEM and the external circuits, nonlinear magnetic properties, eddy-current effect and movement was taken into account. In [12] introduces a review of the two basic designs of linear induction motor (LIM). Two designs (single side and double sided) are introduced. Finally, present new model design of two degree of linear motion in X-Y plane and therefore a multi axis motion. In [13], the 2-D transient electromagnetic field of SLIM is computed using finite element method (FEM) and a novel stator core structure by parametric analysis is proposed. The longitudinal end effect, the distribution and variation of eddy current and electromagnetic force with respective to frequency is analyzed

Abdolamir Nekoubin is with Islamic Azad University, Najaf Abad Branch. (E-mail: nekoubin@yahoo.com).

in detail as well as flux density in air gap. However, they suffer from two major drawbacks i.e. low efficiency and low power factor which cause more energy consumption, a rise in input current and occupation of transmission lines capacity. In [14] presents a multi objective optimization method to improve both efficiency and power factor, simultaneously. For this purpose, the analytical model of machine is employed to calculate the efficiency and power factor. Motor parameters and dimensions are optimized using genetic algorithm and an appropriate objective function. The results show an enhancement in motor performance. Finally, time stepping finite element method is used to evaluate the analytical results. Design optimization of a low speed single-sided linear induction motor for improving efficiency and power factor with conventional method and genetic algorithm in[15] is presented and in [16-18] imperialist competitive algorithm is proposed and with two previous method is compared. In this paper a double-sided linear induction motor, short primary, in different conditions is designed, next with finite element method and maxwell3D software electromagnetically is analyzed. Finally, for dynamic simulation linear motor by using MATLAB software is simulated.

II. MODELING OF DSLIM

The mathematical modeling of linear induction motor in d-q form is given by the following equations:

$$\frac{dI_{ds}}{dt} = \left(\frac{R_s}{\sigma L_s} + \frac{1-s}{6T_s} \right) I_{ds} + \frac{L_m}{6L_s L_r T_r} \lambda_{dr} + \frac{L_m T}{6L_s L_r \tau_t} v \lambda_{qr} + \frac{1}{6L_s} V_{ds} \quad (1)$$

$$\frac{dI_{qs}}{dt} = \left(\frac{R_s}{\sigma L_s} + \frac{1-s}{6T_s} \right) I_{qs} + \frac{L_m}{6L_s L_r T_r} \lambda_{qr} + \frac{L_m T}{6L_s L_r \tau_t} v \lambda_{dr} + \frac{1}{6L_s} V_{qs} \quad (2)$$

$$\frac{d\lambda_{dr}}{dt} = \frac{L_m}{L_r} I_{ds} - \frac{1}{T_r} \lambda_{dr} - \frac{\pi}{\tau_p} V \lambda_{qr} \quad (3)$$

$$\frac{d\lambda_{qr}}{dt} = \frac{L_m}{L_r} I_{qs} - \frac{1}{T_r} \lambda_{qr} - \frac{\pi}{\tau_p} V \lambda_{dr} \quad (4)$$

Where R_r is Primary resistance, R_s : Secondary resistance, L_r : Primary inductance, L_s : Secondary inductance, L_m Magnetizing inductance, T_t Secondary time constant. M : Mass to be transported or accelerated, B : Viscous friction coefficient, F_L : External resistive force, τ Pole pitch, P : Number of poles.

The propulsion force F_t , and attraction force F_a , developed by the linear induction motor, in terms of secondary flux and primary currents is given by the following equation:

$$F_t = \frac{3}{2} P \frac{L_m}{L_r} \cdot \frac{\pi}{\tau_p} (I_{ds} \lambda_{qr} - I_{qs} \lambda_{dr}) \quad (5)$$

$$F_a = \frac{3}{4} \cdot \frac{P}{2} \cdot \frac{L_m}{L_r g} (\lambda_{dr} I_{ds} + \lambda_{qr} I_{qs}) \quad (6)$$

The mechanical equation, balancing the propulsion force with the fiction force, external load force and the accelerating force is given by the following equation:

$$F_t = M \cdot \frac{dV}{dt} + BV + F_L \quad (7)$$

III. NUMERICAL ANALYSIS

Applying Newton's law for linear motor can be written, as:

$$m\ddot{\mathbf{x}} + c\dot{\mathbf{x}} + k\mathbf{x} = \mathbf{F} \quad (8)$$

The electro-magnetic problem and the mechanical problem are coupled through Lorenz's force. Lorenz's force is the net force produced from the electric and magnetic field:

$$F_L = P(J \times \nabla \times \mathbf{A} - \nabla V) \quad (9)$$

Then, the equations of motions yield:

$$m\ddot{\mathbf{x}} + c\dot{\mathbf{x}} + k\mathbf{x} = F_L = P(J \times \nabla \times \mathbf{A} - \nabla V) \quad (10)$$

Finally in order to solve a time dependent problem for example the transient behavior of an electrical motor, the equation (10) needs to be solved. The partial differential equation (10) is nonlinear and there is no analytical solution available. For solving it, a numerical technique is necessary. Many techniques are available; the most common techniques used are Finite Difference Methods (FDM), Finite Element Methods (FEM), and Boundary Element Methods (BEM). In this work, the finite element method is chosen.

IV. ANALYSIS OF LINEAR INDUCTION MOTOR WITH FEM

The LIM considered for analysis here is the double-sided primary, long-sheet-secondary as shown in fig1.

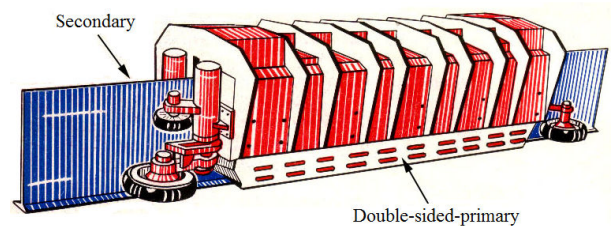

Fig. 1 Double-sided linear induction motor

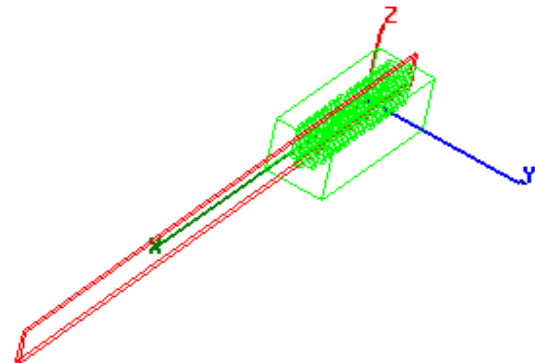

Fig. 2 Double sided linear induction motor, Designed with maxwell3D

In this paper the effect of varying number of poles on the performance of DSLIM is analyzed and the results are discussed. The commercial software selected for this study was Maxwell3D, because it is able to solve the coupled electromagnetic and mechanical dynamic equations. This software is also able to solve two and three-dimensional transient electromagnetic problems. In order to solve the model developed in this work, the three-dimensional version is used. A sketch of DSLIM which designed by using MAXWELL3D is shown in Fig.2. The motor main parameter is shown in table I.

TABLE I
SPECIFICATIONS ADOPTED FOR THE SIMULATED LIM

Components	Part name	Rating values
L_p	Primary Length	0.5 m
L_s	Secondary Length	4m
V	voltage	220
S	Number of Slot	12
τ_p	Pole pitch	0.1209m
V	Linear speed	30m/s
f	frequency	50Hz

Design1: In this section, effect of changing number of poles on Performance is studied. A double-sided linear induction motor with 2 poles, 6 slots in primary and 5 mm air gap between primary and secondary to the finite element method has been simulated. Fig. 3 shows the finite element mesh of the analyzed model. Fig. 4 shows the distributions of the flux density.

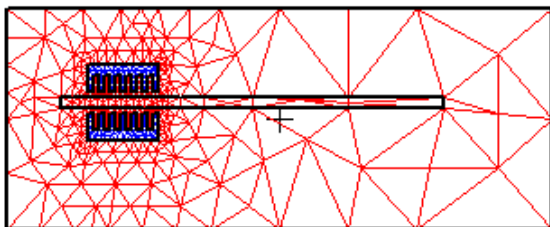

Fig. 3 Finite element mesh of LIM at pole number of 2

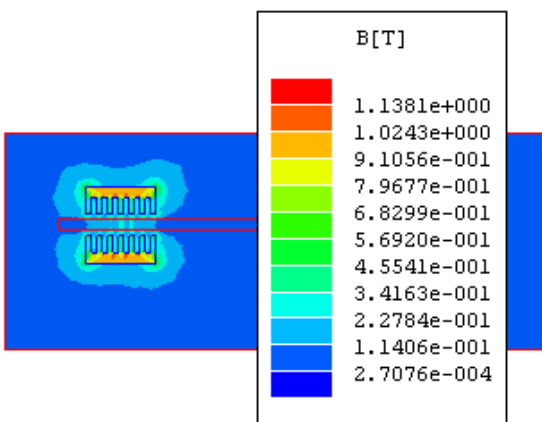

Fig. 4 The flux density of LIM at pole number of 2

Design2: A Double-Sided Linear Induction motor with 4 poles, 12 slots in primary and 5 mm air gap between primary and secondary to the finite element method has been simulated. The results are shown in fig. 5-fig. 6. When the number of poles is increased, the end effects are reduced in the LIM. This is because the end-effect loss is shared by a large number of poles, resulting in a better performing machine. Thus, it is advantageous to have a machine with a large number of poles.

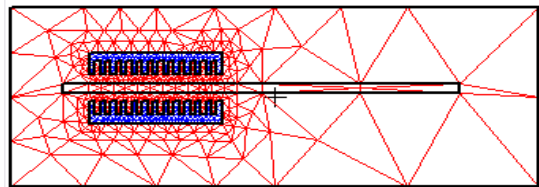

Fig. 5 Finite element mesh of LIM at pole number of 4

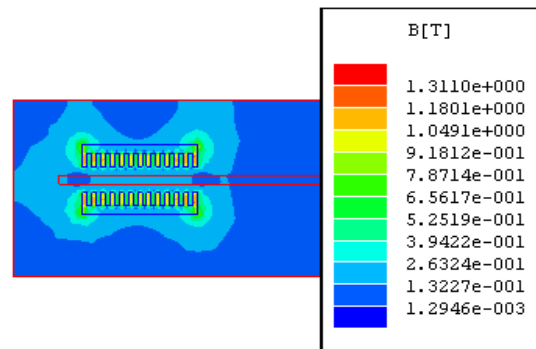

Fig. 6 The flux density of LIM at pole number of 4

Design3: A Double-Sided Linear Induction motor with 8 pole, 24 slot in primary and 5 mm air gap between primary and secondary to the finite element method has been simulated. The results are shown in fig. 7 and fig. 8.

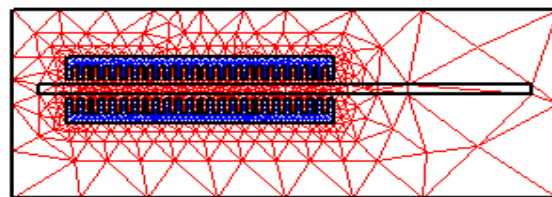

Fig. 7 Finite element mesh of LIM at pole number of 8

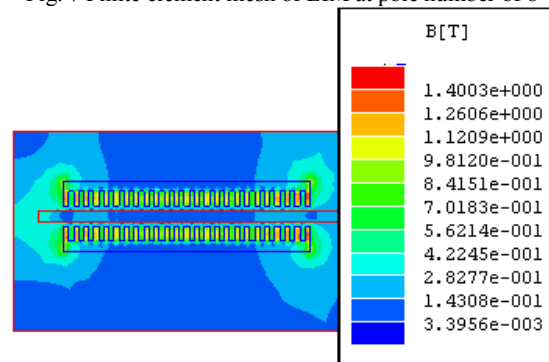

Fig. 8 The flux density of LIM at pole number of 8

The characteristic curves with respect to changing poles are as shown in fig. 9 and fig.10. The thrust increases as we increase the number of poles. Also, from fig. 9 we can see that the efficiency decreases with increase in number of poles. Hence, there is tradeoff between the thrust and the efficiency with increasing number of poles. Also, there is a constraint on the length of the motor, which increases with the increase in number of poles.

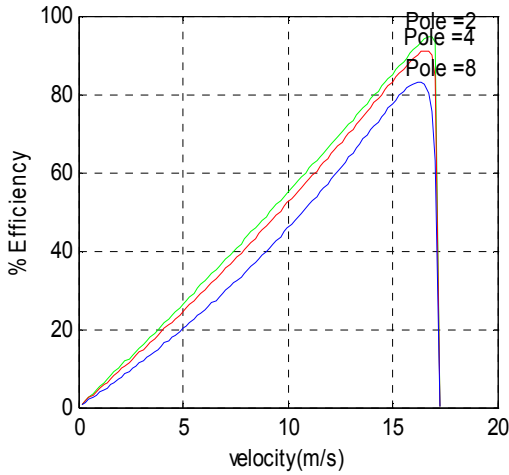

Fig. 9 Effect of number of poles on the efficiency of LIM

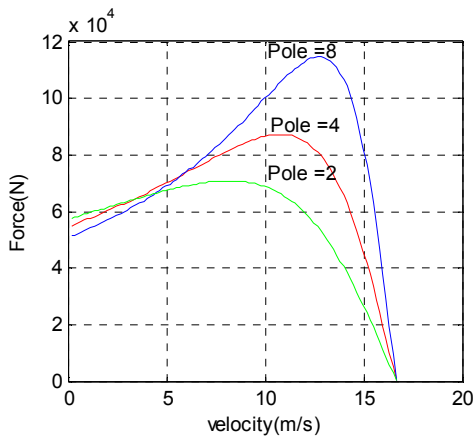

Fig. 10 Effect of number of poles on the thrust of LIM

V. DYNAMIC SIMULATION OF LINEAR MOTOR

For analyzing dynamic behavior of linear motor by using Matlab/Simulink motor is simulated with 2, 4, 8 poles. In this simulations reference speed is 30m/s and reference flux is 0.5 Weber. Simulation results are shown in fig.11-fig.16.

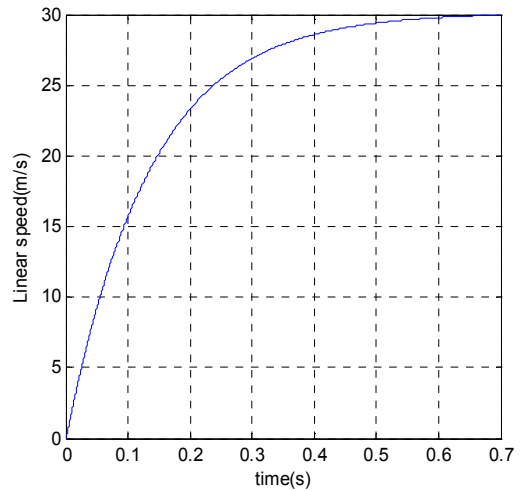

Fig. 11 Linear speed Vs time characteristic for 2 poles motor

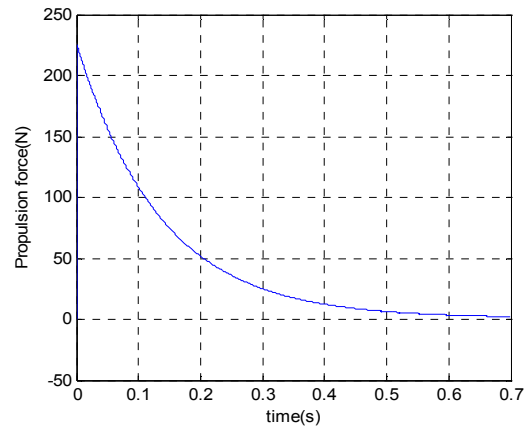

Fig. 12 Propulsion force Vs time characteristic for 2 poles motor

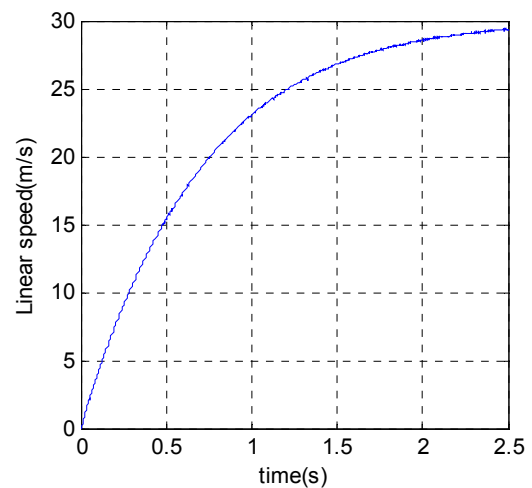

Fig. 13 Linear speed Vs time characteristic 4 poles motor

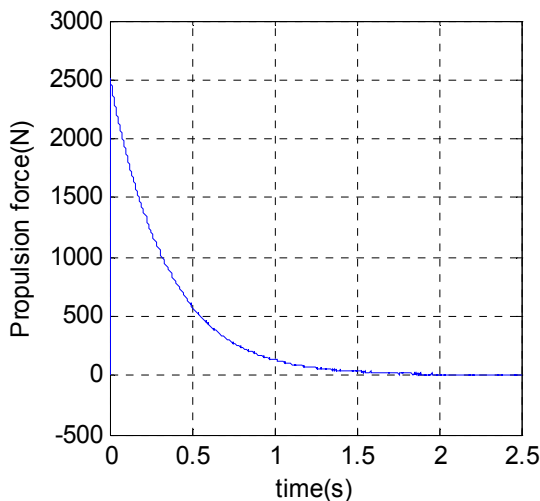

Fig. 14 Propulsion force Vs time characteristic for 4 poles motor

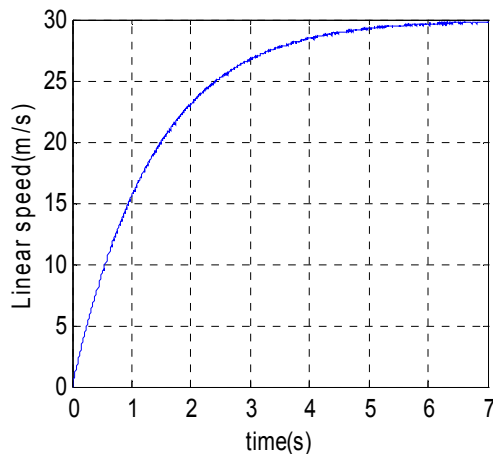

Fig. 15 Linear speed Vs time characteristic 8 poles motor

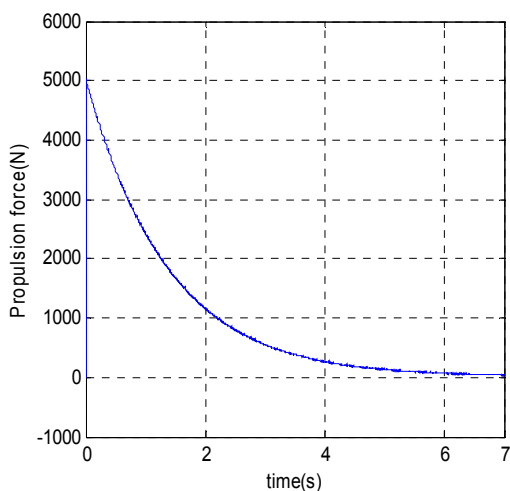

Fig. 16 Propulsion force Vs time characteristic for 8 poles motor

It is seen that with increasing number of poles system time response is increased although propulsion force is increased.

VI. CONCLUSION

By increasing the number of poles, the end effects are reduced, which is good for the DSLIM performance. At the same time thrust is increased but at the expense of efficiency. Hence, there is a tradeoff between the thrust and the efficiency with increasing number of poles. The results of dynamic simulation show that with increasing system time response is increased and motor after more time reaches to steady state. Also propulsion force of motor is increased.

REFERENCES

- [1] O. K. Nam, J. H. Sung, A new approach to vector control for linear induction motor considering end effects, IEEEIAS annual meeting, 3-7 Oct, in Phoenix, Arizona, 2010, pp.2284-2289.
- [2] Chin-I Huang, Li-Chen Fu, Adaptive approach to motion controller of linear induction motor with friction compensation, IEEE/ASME Transactions on Mechatronics, vol. 12, Aug 2007, pp. 334 – 340.
- [3] TSeung-Chan Park, Won-Min Lee, Kyung-Min Kim, Analysis of linear induction motors for MAGLEV according to the secondary conductor structure, International Conference on Electrical Machines and Systems, vol. 2 n. 5, 8-11 Oct. 2007, pp. 1995 – 1998.
- [4] Faa-Jeng Lin, Li Tao Teng, Chih-Kai Chang, Adaptive Back stepping Control for Linear Induction Motor Drive Using FPGA, Annual Conference on IEEE Industrial Electronics, Volume 6, Nov 2006, pp. 1269 – 1274.
- [5] Hassanpour Isfahani A, Ebrahimi BM, Lesani H., Design optimization of a low speed single-sided linear induction motor for improved efficiency and power factor, IEEE Transaction Magnetic, Vol. 44, No. 2, 2008, pp. 266–72. [6] K. Yoshida, et al. New transfer-matrix theory of linear induction machines, taking into account longitudinal and transverse ferromagnetic end effects, Proceeding IEE, Vol. 128, Pt. B, No. 5, Jan. 1981, pp. 225-236.
- [6] Pt. Matsumiya T., Tagagi, K., End effect and equivalent circuit of linear induction machine, IEE, Vol. 91, 1989, pp. 117-127.
- [7] J. Duncan and C. Eng., Linear induction motor-equivalent circuit model, Proceeding IEE, Vol. 130, Pt. B, n. 1, Oct 1983, pp. 51-57.
- [8] Jawad Faiz, Iman Tabatabaei, Extension of Winding Function Theory for Non uniform Air Gap in Electric Machinery, IEEE Transactions on Magnetics, Vol. 38, n.6, November 2002, pp. 3654-3657.
- [9] Dawson, G.E., Eastham, A.R., Gieras, J.F., Performance calculation for single-sided linear induction motors with a double-layer reaction rail under constant current excitation, IEEE Transactions on Magnetics, Vol. 22, n. 1, Jul. 1986, pp.54–62.
- [10] Xialing Long, Theory and Electromagnetic Design Method of Linear Induction Motor, Science Press, Beijing, China, 2006, pp. 103-106.
- [11] Ahmed F. Abd El-Halim, Mohamed A. Ashraf, Ibrahim F. Al-Arabawy, Design Two Degree of Linear Motion X-Y Plane Machine Using Linear Induction Motor, 12th International Middle East Power Systems Conference, Aswan, 12-15 March, 2008, pp. 109 – 113.
- [12] Junfei Han, Yumei Du, Yaohua Li, Nengqiang Jin, Tiejun Zhou, Wei Xu, Study and Optimized Design of Stator Core Structure in Single-Sided Linear Induction Motor, IEEE International Conference on Electrical Machines and Systems, (ICEMS), 2008, pp. 3464 – 3469.
- [13] Hassanpour Isfahani, A., Lesani, H., Ebrahimi, B.M., Design Optimization of Linear Induction Motor for Improved Efficiency and Power Factor, IEEE International Electric Machines & Drives Conference (IEMDC), Vol. 2, 2007, pp. 988 – 991.
- [14] Hassanpour Isfahani A, Ebrahimi BM, Lesani H., Design optimization of a low speed single-sided linear induction motor for improved efficiency and power factor, IEEE Transaction Magnetic, Vol. 44, No. 2, 2008, pp. 266–72.
- [15] Atashpaz-Gargari E, Lucas C., Imperialist competitive algorithm: an algorithm for optimization inspired by imperialistic competition, IEEE Congress on Evolutionary Computation (CEC), vol 2, Oct 2007, pp. 4661 – 4667.

- [16] M. Becheikh, A. Bendiabdellah, Design and Analysis of a Switched Reluctance Motor Using a Coupled FEM-BEM Approach, International Review of Electrical Engineering (IREE), Vol. 5 N. 2, April 2010, pp. 138-148.
- [17] Ghazanfar Shahgholian, Jawad Faiz, Navid Sedri, Pegah Shafaghi, Mehdi Mahdavian, Design and Experimental Analysis of a High Speed Two-Phase Induction Motor Drive for Weaver Machines Applications, International Review of Electrical Engineering (IREE), Vol. 5 N. 2, April 2010, pp. 106-112.

Abdolamir Nekoubin was born in Iran, in 1985. He received the B.S. degree in 2007 and the M.S. degree in 2009, all in electrical engineering from Islamic Azad University, Najaf Abad Branch. His current research interests include induction motor, linear induction motor, and nonlinear control theory. Currently he is member of young researchers club.