

Application of Neuro-Fuzzy Dynamic Programming to Improve the Reactive Power and Voltage Profile of a Distribution Substation

M. Tarafdar Haque, and S. Najafi

Abstract—Improving the reactive power and voltage profile of a distribution substation is investigated in this paper. The purpose is to properly determination of the shunt capacitors on/off status and suitable tap changer (TC) position of a substation transformer. In addition, the limitation of secondary bus voltage, the maximum allowable number of switching operation in a day for on load tap changer and on/off status of capacitors are taken into account. To achieve these goals, an artificial neural network (ANN) is designed to provide preliminary scheduling. Input of ANN is active and reactive powers of transformer and its primary and secondary bus voltages. The output of ANN is capacitors on/off status and TC position. The preliminary schedule is further refined by fuzzy dynamic programming in order to reach the final schedule. The operation of proposed method in Q/V improving is compared with the results obtained by operator operation in a distribution substation.

Keywords—Neuro-fuzzy, Dynamic programming, Reactive power, Voltage profile.

I. INTRODUCTION

NOWADAYS, power quality is one of the most important topics from electrical energy consumers' point of view. Among different power quality factors such as voltage harmonics, voltage imbalance, voltage sag, voltage swell and flicker, it is possible to say that voltage magnitude regulation and reactive power compensation is the most common problems. The power distribution transformers uses under load tap changers for voltage magnitude regulation. On the other hand, usually there are some capacitors in distribution substations for reactive power compensation. Determination the best tap changer (TC) position and shunt capacitors on/off status is very important factor in distribution network operation. The voltage magnitude of primary and secondary side of transformer and active and reactive power of load are the factors which should be taken in account for determination of TC position and on/off state of capacitors. In conventional distribution substations, this decision should be execute base on operators knowledge and expert that is not usually precise enough and it is very difficult to decide what to do. It should be noticed that such a decisions should be done on line and very fast.

Neural networks (NNs) can be use to solve the reactive power and/or voltage profile improvement of distribution substations [1-4]. Input of NN is active and reactive powers of transformer and its primary and secondary bus voltages and its

The authors are with Department of Electrical and Computer Engineering, Tabriz University, Tabriz, Iran (e-mail: tarafdar@tabrizu.ac.ir).

output is capacitors on/off status and TC position. The main advantage of neural network is its flexibility with multiple and noisy data and its main drawback is long time required for training feed forward network with back-propagation training algorithm, especially when dimension of the power network is high. To solve these problems the neuro-fuzzy method is used in this paper [5].

II. POWER SYSTEM STRUCTURE

Fig. 1 shows one line diagram of a distribution substation. The power circuit topology consists of a main transformer with on load tap changer (OLTC). The primary side voltage is 69 (kv) while the secondary is 11.4 (kv). In low voltage side, there are shunt capacitor feeders and the loads. The primary and secondary side voltages and the active and reactive power of load should be forecast for next 24 hours (e.g. using a NN) using the measured values of today.

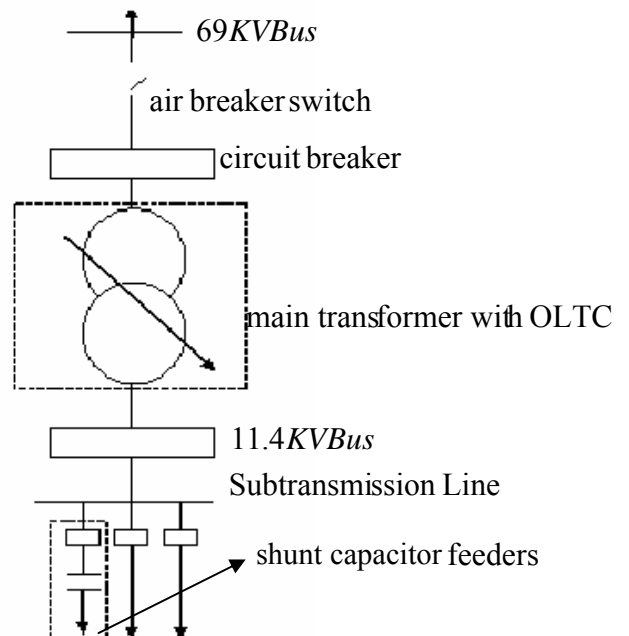

Fig.1 One-line diagram of a 69/11.4 kv distribution substation

III. PROPOSED N.N. ARCHITECTURE

A multilayer feed forward neural network as shown in Fig. 2 is employed to achieve the preliminary dispatch schedule for determination of tap position and capacitor on/off status. Designed N.N comprises of three layers. Input layer with four

neurons, hidden layer with 11 neurons and the output layer with two neurons. The transfer function of input and output layer is logarithm-sigmoid while it is tangent-sigmoid for middle layer.

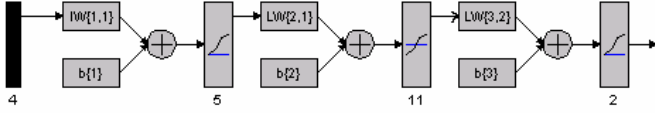

Fig. 2 A three layer feed forward neural network

IV. FUZZY DYNAMIC PROGRAMMING (F. D. P.) APPROACH

The proposed fuzzy dynamic programming approach is including maximization of an objective function as below:

$$J = \sum_{i=1}^{24} \mu_{|\Delta\tilde{V}_{2i}|} + \sum_{i=1}^{24} \mu_{\tilde{p}f_i} + \mu_{\tilde{N}_{tap}} + \mu_{\tilde{N}_c} \quad (1)$$

$$= J_1 + J_2 + \mu_{\tilde{N}_{tap}} + \mu_{\tilde{N}_c}$$

This function guarantees the overall minimum of voltage deviation at secondary side, power factor compensation, tap changing steps and on/off numbers of capacitors in a 24 hour interval. Indeed, the fuzzy dynamic programming optimizes the output of NN. This function is minimized subject to the following conditions:

$$N_{tap} = \sum_{i=2}^{24} |TAP_i - TAP_{i-1}| \leq 30 \quad (2)$$

$$N_c = \sum_{i=2}^{24} |X_i - X_{i-1}| \leq 6 \quad (3)$$

$$|V_2^{\min}| \leq |V_{2i}| \leq |V_2^{\max}| \quad (4)$$

$$|pf_i| \geq 0.8 \quad (5)$$

where :

$\Delta\tilde{V}_{2i}$ = secondary bus voltage deviation from the specified value at hour i

$\mu_{|\Delta\tilde{V}_{2i}|}$ =membership function of $|\Delta\tilde{V}_{2i}|$ at hour i

pf_i = main transformer power factor at hour i

$\mu_{\tilde{p}f_i}$ =membership function of $\tilde{p}f_i$ at hour i

N_{tap} = total switching number of LTC in a day

$\mu_{\tilde{N}_{tap}}$ = membership function of \tilde{N}_{tap} at hour i

N_c = total switching number of capacitor in a day

$\mu_{\tilde{N}_c}$ = membership function of \tilde{N}_c at hour i

$|V_2^{\min}|$ = the lower limit of secondary bus voltage (0.95 p.u.)

$|V_2^{\max}|$ = the upper limit of secondary bus voltage (1.05 p.u.)

Equation (2) limits the overall tap position changing to 30 in a day. Equation (3) limits the overall on/off state of capacitors 6 in a day. These numbers are derived from real operation experts of distribution substations but they can be set to any desired value. Equation (4) regulates the secondary bus voltage between a lower and an upper limit. In this paper the lower and upper values are 0.95 and 1.05 per unit, respectively, while the 11.4 kv is considered as base value. Equation (5) guarantees the power factor of secondary side of transformer to be more than 0.8 in all of hours of a day.

V. COMPARISON OF F.D.P AND ORDINARY CONTROL RESULTS IN A REAL DISTRIBUTION SUBSTATION

The measured values of primary and secondary bus voltages in addition to real and reactive power measuring results in a distribution substation with a power circuit topology similar to Fig. 1 is used to examine the operation of explained method. The rated power of transformer is 33.33 (MVA) with 69 kv-Y/11.95 kv- Δ , the capacitor bank in secondary side is 8.4 (MVAR). The measured values in a day is feed to a N. N. for short term load forecasting of tomorrow in hourly based. Based on forecasted values, the explained neuro-fuzzy dynamic programming (F. D. P.) strategy is examined and the results are compared with the real monitored values. It should be noticed that the monitored values are resulted from ordinary control method that is based on operator experts and decisions. Figs 3 to 6 show some of selected diagrams. Fig. 3 shows the on/off states of capacitors. There is only a difference in 21 hour between FDP and monitored values. Fig. 4 shows the tap changer positions. This figure shows almost a considerable difference between FDP and monitored values.

Fig. 5 shows the variations of secondary side voltages of transformer. It is obvious that the results of FDP are much better than ordinary method in voltage magnitude regulation. For example, in ordinary method there are some hours (e.g. 7, 21, 22 and 23) in which the voltage values have been even less than 0.96 p.u., while the voltage magnitude with FDP is always between its limits (i.e. 0.95 and 1.05 p.u., respectively).

Fig. 6 shows the variations of power factor in a day by FDP and ordinary method. The power factor compensation is almost same with both methods but using sm of square of errors shows better operation of FDP compared with ordinary method, too.

Considering the obtained results it seems the FDP method not only facilitates the decision making procedure by operator, but also it achieves to better results in operation of distribution substations.

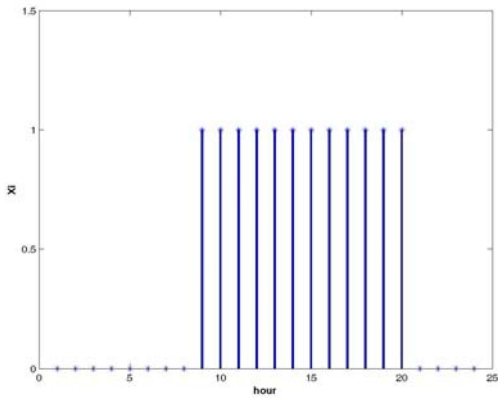

(a) Ordinary method

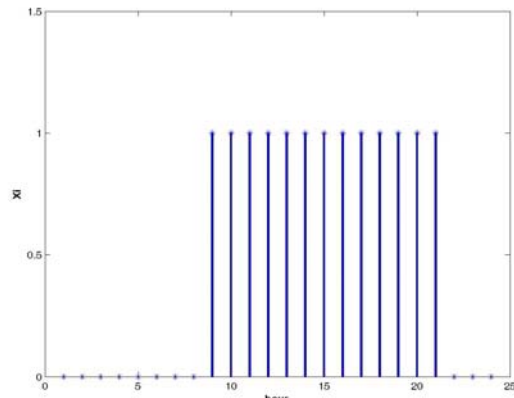

F. D. P. method

Fig. 3 on/off states of capacitors

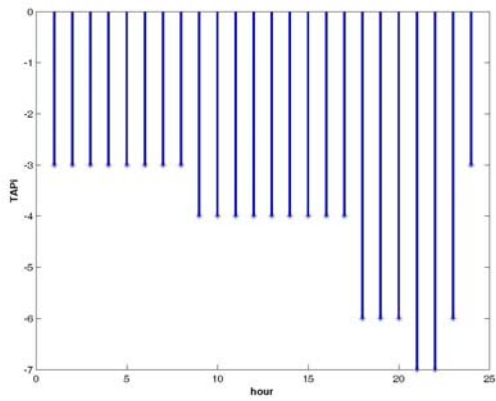

(a) Ordinary method

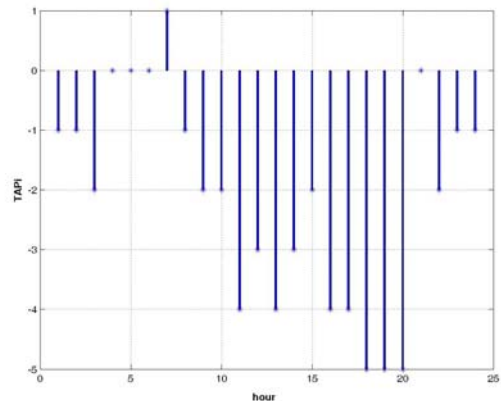

F. D. P. method

Fig. 4. On load tap changer position

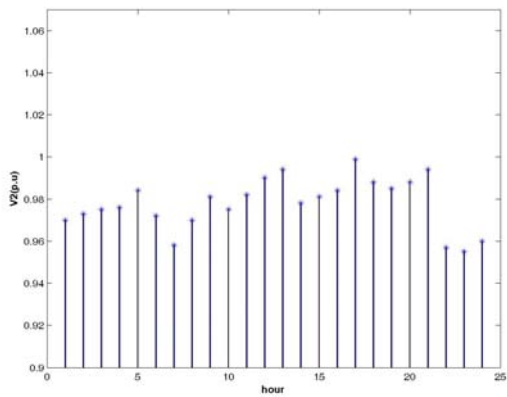

(a) Ordinary method

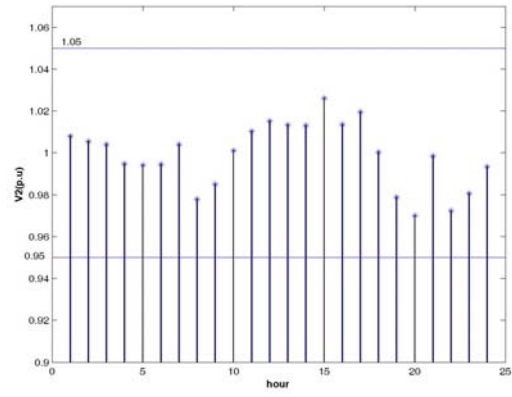

F. D. P. method

Fig. 5 Secondary side voltage of distribution transformer

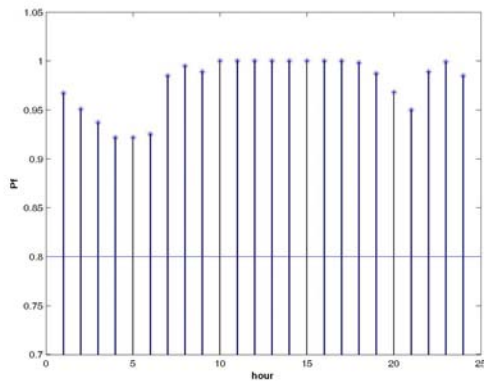

(a) Ordinary method

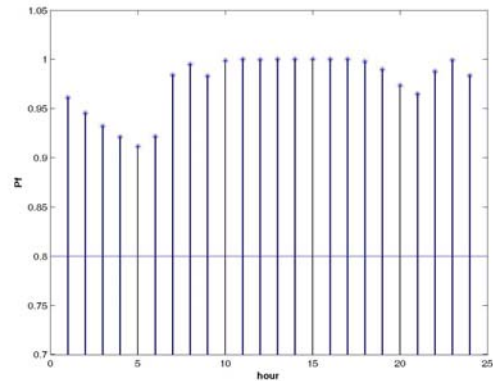

F. D. P. method

Fig. 6 Power factor variations

VI. CONCLUSION

A neuro-fuzzy dynamic programming method is used in this paper for reactive power and voltage profile improvement of a distribution substation, successfully. This method is able to determine the suitable tap position of transformer and capacitor on/off states at each hour of next day using short term load forecasting results. This method can regulate the voltage magnitude at the secondary bus voltage of main transformer. It can compensate for power factor using suitable on/off states of capacitors. Reduction of computation burden and considering some limiting parameters such as the number of tap changing of main transformer, on/off states of capacitors, voltage magnitude and power factor are other advantages of using of this method.

REFERENCES

- [1] Feng – Chang Lu , Yuan – Yih Hsu , " *Fuzzy Dynamic PROGRAMMING Approach to Reactive Power/Voltage Control in a Distribution Substation* " IEEE Trans. on Power System , Vol. 12, No. 2, May 1997, pp. 681 – 688.
- [2] Yuan – Yih Hsu , Fen – Chang Lu, " *A Combined Artificial Neural Network – Fuzzy Dynamic Programming Approach to Reactive Power/Voltage Control in a Distribution Substation* ", IEEE Trans. on Power systems, Vol.13, No. 4, November 1998, pp.1265-1271.
- [3] F. C. LU, Y. Y. HSU, "Reactive Power/Voltage Control in a Distribution Substation Using Dynamic Programming" IEE Proc. Generation Transmission and Distribution, Vol. 142, No. 6. November 1995, pp. 639 – 645.
- [4] K. Warwick, A. Ekwure, R. Aggarwal, " *Artificial Intelligence Techniques in Power Systems*", IEE Power Engineering Series 22, Bookratt Printed, pp. 17-19, 1997.
- [5] K. Tomosovic, " *A Fuzzy Linear Programming Approach to the Reactive Power/Voltage Control Problem*", IEEE Trans. Power Systems, 1992, pp. 87-293.