

Optimum Shape and Design of Cooling Towers

A. M. El Ansary, A. A. El Damatty, and A. O. Nassef

Abstract—The aim of the current study is to develop a numerical tool that is capable of achieving an optimum shape and design of hyperbolic cooling towers based on coupling a non-linear finite element model developed in-house and a genetic algorithm optimization technique. The objective function is set to be the minimum weight of the tower. The geometric modeling of the tower is represented by means of B-spline curves. The finite element method is applied to model the elastic buckling behaviour of a tower subjected to wind pressure and dead load. The study is divided into two main parts. The first part investigates the optimum shape of the tower corresponding to minimum weight assuming constant thickness. The study is extended in the second part by introducing the shell thickness as one of the design variables in order to achieve an optimum shape and design. Design, functionality and practicality constraints are applied.

Keywords—B-splines, Cooling towers, Finite element, Genetic algorithm, Optimization

I. INTRODUCTION

MANY investigations related to the subject of optimal design of shell structures have been performed previously while assuming that the shell surface has a fixed geometry. The thickness of the shell is considered as the independent design variable in such cases. Few studies have considered an important class of optimization problems in which the geometry defining the surface of the shells is treated as an independent design variable. This category of problems is called “Structural Shape Optimization”, and it usually requires an interaction between three different schemes. The first scheme is employed to define the geometry of the surface using a certain set of independent variables. The second scheme is a tool used to predict the structural response, which is usually done numerically. The third scheme is an appropriate optimization algorithm that can determine the optimum solution in an effective and reliable way. A number of techniques were used by various researchers to solve shape optimization structural problems. Many researchers, such as Zienkiewicz and Campbell [1], and Ramakrishnan and Francavilla [2], used the nodal coordinates of the discrete finite element model as the design variables that define the geometry of the surface. The drawback of this approach is that it involves a large number of design variables and often leads to edged shapes. In order to overcome the edged shape problem, a large number of constraints must be added, which

leads to difficulties in applying this approach. Yang et al. [3], and Chang and Choi [4] used mesh parameterization methods to define geometric and numerical models in order to overcome the problems of the previous method. In this approach, a set of key points “master nodes” are used to define the geometry of the surface. Parametric mappings are then employed to map this geometric model to the finite element mesh. As such, the shape design variables are considered as a set of parameters that defines the position of the master nodes. However, this approach is difficult because the user has to define the model in terms of these master nodes rather than the dimensions, which is not an easy task especially when dealing with complex shapes. Several shapes have been used in the past for the structural shell of cooling towers. Cylindrical towers have been constructed, and many European towers have been composed of a frustum of a cone surmounted by a section of a torus, with another conical section at the top. These types have been superseded by the hyperbolic towers, which are relatively easy to analyze and exhibits primarily membrane stresses under design loads, as stated by Gould and Lee [5]. A study that was conducted by Pieczara [6] represented the surface of the cooling tower based on two hyperbola curves that intersect at the tower throat, where the objective function is set to minimize the thickness of the tower shell. The main objective of the current study is to develop an innovative technique to predict the optimum shape and optimum structural design of cooling towers. The study is divided into two main parts. In the first part, shape optimization of the tower, with shell rings radii taken as design variables, is formulated taking into account various constraints such as strength requirements, buckling capacity, practicality of construction, and functionality of the structure. The objective function is set to be the optimum shape corresponding to minimum weight (volume of shell material) under equivalent wind pressure and dead load. The study is extended in the second part by introducing the shell thickness as an extra design variable in order to predict an optimum shape and the corresponding optimum thickness. The proposed numerical tool involves a combination between three numerical schemes. These are the B-spline curves, which are adapted to generate the finite element mesh, finite element modeling (FEM) to study the response of the tower under the effect of design loads, and Real Coded Genetic Algorithm (RCGA) optimization technique. A detailed description of these three techniques is provided in next sections.

II. DESCRIPTION OF THE GEOMETRY OF THE TOWER

For purposes of comparison, a real tower is considered in the current study as the “reference design” tower. The total height of the tower is 108.2 m. As shown in Fig. 1, the tower has a base, throat and top radii of 39.3 m, 25.1 m and 27.4 m,

A. M. El Ansary was a Postdoctoral Research Fellow at the University of Western Ontario, London, Ontario, Canada. He is now a Postdoctoral Research Fellow at King Abdullah University of Science and Technology KAUST, Thuwal, KSA. (e-mail: aelansar@alumni.uwo.ca).

A. A. El Damatty, Professor, Associate Chair for Graduate Studies, Department of Civil and Environmental Engineering, The University of Western Ontario, London, Ontario, Canada N6A 5B9 (phone: +15196612111 ext. 88203; fax: +15196613779; e-mail: damatty@uwo.ca).

A. O. Nassef, Professor, Department of Mechanical Engineering, The American University in Cairo, Egypt. (e-mail: nassef@aucegypt.edu).

respectively, with the throat located 76.8 m above the base. It has a constant shell-wall thickness of 190.5 mm.

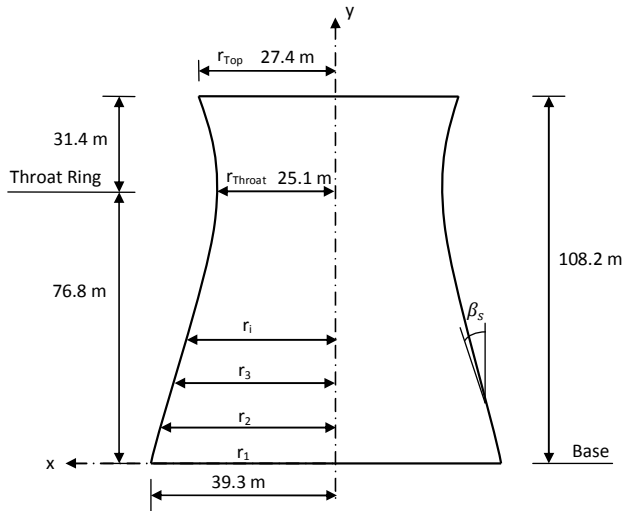

Fig. 1 Geometry of the real tower considered in the current study

Detailed description of the geometry of the tower is presented in Table I. This table shows the radius and location of each of the eleven rings distributed along the tower height. The tower is constructed of reinforced concrete having a compression strength of 30 MPa, tensile strength of 1.81 MPa, unit weight of 24 kN/m³, Poisson's ratio of 0.3 and elastic modulus of 25 GPa. The total height of the tower, h , and the radius of its base, r_1 , are generally governed by thermal design considerations. As such, these two parameters are assumed to be fixed in all the optimization analyses carried in this study. In addition, the inner volume of the tower is usually selected in order to achieve a certain cooling capacity. This condition is applied in the numerical model through imposing a functionality constraint as will be discussed later.

TABLE I
GEOMETRY OF COOLING TOWER UNDER CONSIDERATION

| Ring No. | Ring radius (m) | Ring location from base (m) |
|-----------------|-----------------|-----------------------------|
| $r_1(m)$ | 39.3 | 0.0 |
| $r_2(m)$ | 37.9 | 5.5 |
| $r_3(m)$ | 35.8 | 12.8 |
| $r_4(m)$ | 32.5 | 25.6 |
| $r_5(m)$ | 29.6 | 38.4 |
| $r_6(m)$ | 27.4 | 51.2 |
| $r_7(m)$ | 25.8 | 64.0 |
| $r_{throat}(m)$ | 25.1 | 76.8 |
| $r_8(m)$ | 25.4 | 89.3 |
| $r_9(m)$ | 26.5 | 102.1 |
| $r_{top}(m)$ | 27.4 | 108.2 |

As shown in Fig. 1, a typical meridional shape of a hyperbolic cooling tower shell consists of lower and upper hyperbola branches, which meet at the throat. The curvature of the meridian varies along the tower height, with a maximum value at the throat. As pointed out by Kratzig and Zerna [7], the shape of the meridian affects the magnitude and distribution of the membrane stresses, the load level at which crack initiates, and the structural safety against instability. It

should be mentioned that the shape of the meridian is explicitly controlled by the slope angle, β_s shown in Fig. 1.

III. DESIGN LOADS

Hyperbolic cooling towers are subjected to different types of loading. Most commonly are dead load and wind loads, which are considered in the current study as the design loads. Wind loading is extremely important in the design of cooling towers for several reasons. The overturning moment as well as the localized bending moment resulting from wind loading lead to tension stresses, which can exceed the compression stresses resulting from the structure own weight. The amount of reinforcement needed in the shell is controlled by the net difference between the tension and compression stresses. The distribution of wind pressure varies along both the vertical (y) and circumferential (θ) directions of the shell surface. In the current study, the external wind pressure $w(y, \theta)$ is defined using the following equation provided by ASCE [8]:

$$w(y, \theta) = C_p(\theta) \cdot q_D(y) \cdot G_F \quad (1)$$

Where $C_p(\theta)$: Coefficient for circumferential distribution of wind pressure as provided by Niemann [9]. Its variation with the circumferential angle (θ) is shown in Fig. 2. In this figure, $\theta=0^\circ$ corresponds to the wind direction.

$q_D(y)$: Design wind pressure profile above the ground level for a return period of 50 years.

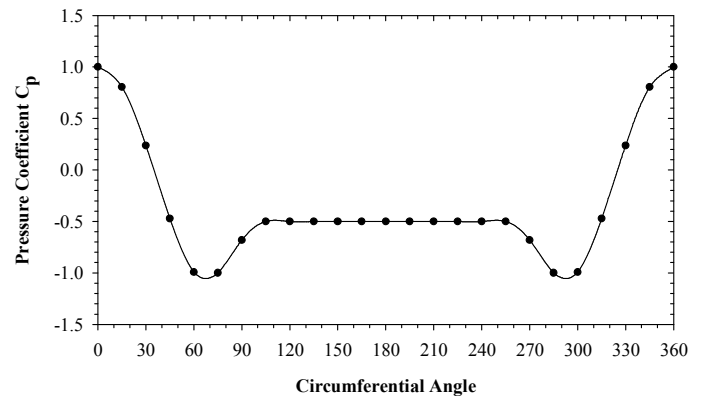

Fig. 2 Distribution of mean pressure coefficient $C_p(\theta)$ defined by Niemann [9]

In the current study, the profile for the case of flat and open country is used, since it represents the most critical case. Such a profile is provided by Niemann [9] and is given in Fig. 3.

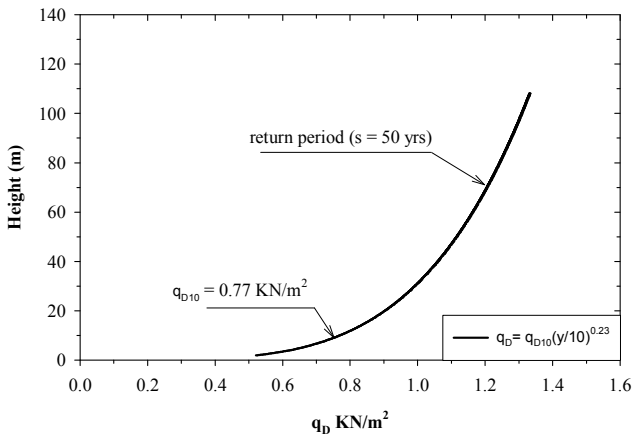

Fig. 3 Design wind load profile defined by Niemann [9]

G_F : Gust factor that takes into account the additional wind effects due to turbulence.

Based on the ASCE-7-98 [10] and assuming a damping ratio of 1%, a value of $G_F = 1.70$ can be used. However, in view of the boundary layer wind tunnel pressure data reported by Vickery et al. [11], and analyses conducted by El Ansary [12], a gust factor $G_F = 2.08$ is recommended to be used in the current investigation.

In this investigation, the design of the cooling tower is assumed to be governed by the limit state of serviceability. As such, the load combination applied in this study is assumed to be wind pressure and dead load with a load factor of 1.0.

IV. DESCRIPTION OF THE NUMERICAL MODEL

As mentioned above, the proposed numerical model involves a combination between the three following numerical schemes: B-spline curves, finite element modeling (FEM), and real coded genetic algorithm (RCGA) optimization technique. This section provides a brief description of these three numerical schemes, as they are employed in the proposed numerical tool. The interaction between various components of the model and the sequence of the algorithm are described in details in the next section.

A. Geometric Modeling of the Tower

A surface of revolution is generated by the rotation of a general form curve around an axis, as shown in Fig. 4. This general curve is known as the generatrix. Surfaces of revolution can be described mathematically in their most general form using Non-Uniform Rational B-splines (NURBS), where the generatrix can be a general (NURBS) curve given by the following equation:

$$C(v) = \sum_{j=0}^m R_{j,q}(v) \cdot P_j \quad (2)$$

where, $C(v)$ is any point on the curve corresponding to the independent variable $v \in [0,1]$, P_j is the set of control points approximating the curve with a number of $(m+1)$ and $R_{j,q}(v)$ is the j -th rational B-spline function of a specific degree q given by the following equation:

$$R_{j,q}(v) = \frac{w_j \cdot N_{j,q}(v)}{\sum_{i=0}^m w_i \cdot N_{i,q}(v)} \quad (3)$$

where, $N_{i,q}$ is the continuous B-spline function, and w is a vector of weights whose elements range from zero to one. The B-spline function is defined on a vector V , known as the knot vector. Such a vector divides the domain of the independent variable v into sub-regions. More details and description of NURBS are given by Piegl and Tiller [13]. In the current study, the generatrix curve $C(v)$ of the cooling tower is defined assuming the following parameters: $q = 2$ and $m = 10$. This curve is rotated around the y -axis and along a circular curve $G(u)$, as shown in Fig. 4. Such a circular curve is represented by (NURBS) with the following parameters:

$$p = 2, n = 8, w = \{1, \cos(45), 1, \cos(45), 1, \cos(45), 1, \cos(45), 1\},$$

$$U \left\{ 0, 0, 0, \frac{1}{4}, \frac{1}{4}, \frac{1}{2}, \frac{1}{2}, \frac{3}{4}, \frac{3}{4}, 1, 1, 1 \right\}$$

As shown in this figure, the 9 control points take the form of a square, which is known as the control polygon. Both curves are combined together into one NURBS surface equation as follows:

$$S(u, v) = \sum_{i=0}^8 \sum_{j=0}^m R_{i,2,j,q}(u, v) \cdot P_{i,j} \quad (4)$$

The surface control points $P_{i,j}$ are generated by revolving the generatrix control points along the path of the circle's control points. A mesh of points creating the surface can be formed by substituting the proper values for the independent parameters u and v .

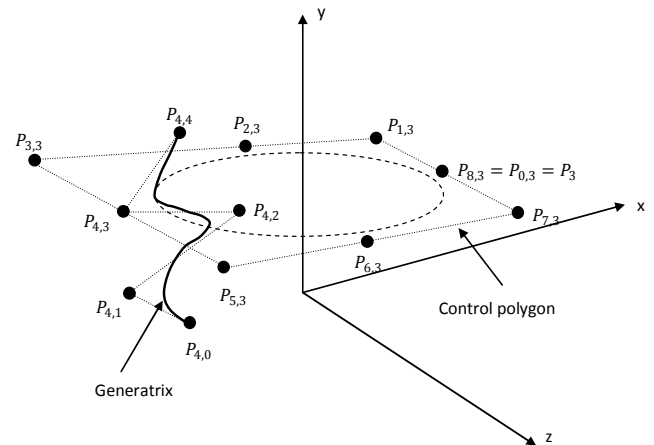

Fig. 4 B-spline curve representing surface of revolution

B. Finite Element Formulation

A consistent sub parametric triangular shell element that was developed by Koziy and Mirza [14] and extended by El Damaty et al. [15] to include the geometric nonlinear effects is used to develop the numerical model of the tower. One of the main advantages of this element is being free from the shear locking phenomenon observed in isoparametric shell elements

commonly used in many commercial software. This element has 13 nodes, as shown in Fig. 5, where the degrees of freedom of the element include displacements u , v and w along the global x , y and z coordinates, respectively and rotational degrees of freedom α , β , ϕ and ψ acting at the corner and mid-side nodes, where rotations α and ϕ are about the local y' axis and rotations β and ψ are about the local x' axis, where the local axes y' and x' are located in a plane tangent to the surface. Rotations α and β are constant through the depth of the element, while rotations ϕ and ψ vary quadratically. Thus, α and β provide a linear variation of displacements u , v and w along the thickness representing bending deformations, while ϕ and ψ lead to a cubic variation of displacements u , v and w , simulating transverse shear deformations. More details about the formulation of this element can be found by Koziey and Mirza [14].

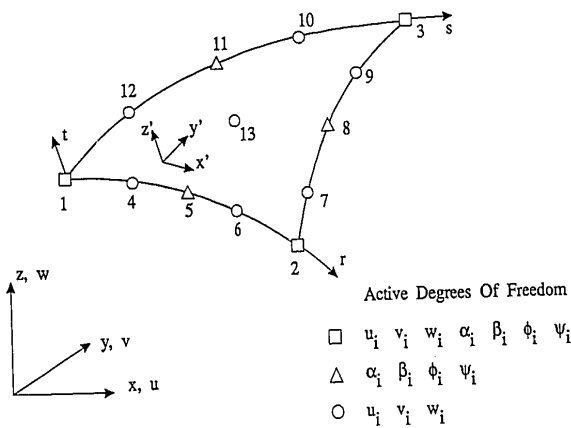

Fig. 5 Consistent shell element coordinate systems and degrees of freedom

1. Finite element mesh and assumptions

A 3-D FEM of the full scale tower is developed using 480 elements, with 24 elements along the horizontal directions and 20 elements along the vertical direction. The following assumptions are used, while developing the numerical model of the cooling tower:

- The base of the tower is assumed to have a simply supported boundary condition.
- Linear elastic behavior of the material is assumed in all analyses. This is justified by the fact that the design of such reinforced concrete structures is controlled by a no-cracking condition.

C. Optimization Technique

Two different techniques are available in the literature for solving general nonlinear optimization problems. These are the direct search and global search techniques. Direct search techniques are local optimization methods as they start the search with a guess solution, while the global search techniques are global optimizers. In the current study, the search space is expected to be complex and may contain several local minima due to the intersection of the constraints with the objective function. As such, a global optimization method is needed to avoid being trapped in local minimum

and to reach a global optimum solution. The global optimization technique used in this study is the real coded genetic algorithm (RCGA), in which design variables are encoded as real numbers. This algorithm is used due to its great versatility, ease of implementation, and its ability to find out the global optimum solution. A complete description of genetic algorithm techniques is given by Goldberg [16] and Davis [17] among other available references. In order to apply (RCGA) to the optimization problem in hand, some parameters in the model should be defined. These parameters are: design variables, design constraints and genetic operators. These parameters are described in the following subsections.

1. Design variables

The x , y and z coordinates of the B-spline control points together with the shell thickness are the design variables considered in the study. The x , y and z coordinates specify the location of each control point $P_{i,j}$, as shown in Fig. 4. Each control polygon is assumed to have a predefined height corresponding to the location of each ring in the full scale tower, as shown in Table I. As such, the number of design variables, which specify the location of the control points, is reduced to only the x and z coordinates. Such a reduction is due to the fact that all control points forming a specific control polygon have the same y -coordinate. It should be mentioned that the values of x and z coordinates of the control points forming a specific control polygon are directly controlled by the assumed radius of the ring corresponding to this polygon. The location of the control points in each level is explicitly represented by the radius of the ring located in such a level. The assumed lower and upper bounds of all design variables (rings radii and shell thickness) are shown in Table II. The lower bound of the shell thickness is assumed based on design and practicality requirements to provide sufficient cover for the reinforcement, as stated by Gould and Kratzig [18].

2. Design constraints

Three different sets of constraints are considered in the analyses. They are classified as (a) structural design, (b) practical requirements, and (c) functionality constraints.

TABLE II
GEOMETRY OF COOLING TOWER UNDER CONSIDERATION

| Design Variable | Lower bound | Upper bound |
|------------------|-------------|-------------|
| $t (m)$ | 0.16 | 0.22 |
| $r_1 (m)$ | 39.3 | 39.3 |
| $r_2 (m)$ | 35.5 | 39.3 |
| $r_3 (m)$ | 33.5 | 39.3 |
| $r_4 (m)$ | 30.5 | 33.5 |
| $r_5 (m)$ | 27.5 | 30.5 |
| $r_6 (m)$ | 23.0 | 30.5 |
| $r_7 (m)$ | 23.0 | 30.5 |
| $r_{Throat} (m)$ | 23.0 | 30.5 |
| $r_8 (m)$ | 23.0 | 30.5 |
| $r_9 (m)$ | 25.0 | 30.5 |
| $r_{Top} (m)$ | 25.0 | 33.5 |

The structural design constraints are:

- The thickness of the tower should be sufficient such that the structure can sustain the design loads without losing its stability by elastic buckling.
- The maximum circumferential and meridional compressive stresses acting on the shell should be less than the allowable stresses due to sustained load.
- The maximum circumferential and meridional tensile stresses acting on the shell should be less than the maximum allowable tensile strength. This condition is imposed to prevent shell cracking under the effect of wind loads.

The constraints related to practicality requirements are:

- At any point along the height, the slope of the shell surface β_s , shown in Fig. 1, should not exceed a certain value, which is governed by the maximum slope that can practically be adopted in the form-work system. Based on practicality and experience, a maximum value for β_s , should not exceed 20° , as stated by Busch et al. [19].

The constraints related to functionality are:

- The inner volume (V) of the tower is assigned to have a specific capacity, which is controlled by the cooling capacity requirements. To apply this equality constraint, the inner volume of the tower is evaluated based on approximating the surface of the tower to a number of conical frustum shapes corresponding to the number of rings along the height of the tower. Based on this approximation, the inner volume of the tower is evaluated according to the following equation:

$$V = \sum_{i=1}^m (h_{i+1} - h_i) \cdot (r_i^2 + r_i \cdot r_{i+1} + r_{i+1}^2) \quad (5)$$

Where $(m + 1)$ is the number of rings along the height of the tower, and r_i is the radius of the base ring, which has a fixed specified value. The number of design variables is reduced by expressing the radius of the top ring of the last conical frustum r_{m+1} in terms of both the radius of the previous ring r_m and the inner volume of such frustum. As such, by assigning a specific cooling capacity to Eq. (5), the equality constraint forces the optimum solution to exactly achieve such required capacity.

To apply the first two sets of constraints, the infeasible solutions are penalized by applying suitable penalty functions. The stationary penalty functions, which use a fixed penalty value throughout the minimization process, are used to apply the elastic buckling constraint. The nonstationary penalty functions, where the penalty values are dynamically modified, are applied to both the tensile strength and the practicality constraints. Generally, a penalized function can be defined by the following equation:

$$f_p(P_{i,j}) = f(P_{i,j}) + \sum_{k=1}^n \phi_k(P_{i,j}) \cdot \delta_k \quad (6)$$

$$\text{where } \begin{cases} \delta_k = 1, \text{ if constraint}(k) \text{ is violated} \\ \delta_k = 0, \text{ if constraint}(k) \text{ is satisfied} \end{cases}$$

n is the number of constraints, $P_{i,j}$ are the design variables, $f(P_{i,j})$ is the unpenalized objective function, $f_p(P_{i,j})$ is the penalized objective function, and $\phi_k(P_{i,j})$ is a suitable constant imposed for violation of constraint k . This constant ensures that the summation terms in the above equation have the same order of magnitude so that the search is not dominated by one of the constraint functions. The values of these constants are obtained by running a Monte Carlo simulation of the independent values prior to the optimization step and obtaining the value of the objective and constraint functions corresponding to each simulation. In the current study, the value of the constant ϕ_1 is assumed to be equal to 10^6 in case of fixed penalty values; while for case of dynamically modified penalty values the parameter $\phi_k(P_{i,j})$ is defined according to the following relations:

$$\phi_2(P_{i,j}) = 10^6 (\sigma_t - \sigma_L) \quad (7)$$

where σ_t is the maximum tensile stresses acting on the tower shell and σ_L is the allowable tensile strength.

$$\phi_3(P_{i,j}) = 10^6 (\beta_s - \beta_L) \quad (8)$$

Where β_s is the maximum slope of the tower shell and β_L is the maximum slope that can practically be adopted in the form-work.

3. Genetic operators

The genetic algorithm technique involves the application of selection, crossover and mutation operators. This technique starts first by a random selection of a specific number of towers having different geometry and different thickness. The number of the randomly chosen towers is usually specified by the user. Such set of randomly chosen towers is known as the initial population. This step is followed by applying crossover and mutation operators to selected pairs of towers in the population in order to generate new towers having geometrical configuration and thickness, which lead to a reduction in own weight. These new generations “towers” replace the worst ranked ones. Details of such operators are given by Michalewicz and Fogel [20]. In the current investigation, the following operators are applied on each population with a size of 100 candidates “towers” according to the following configuration:

- 5 instances undergo uniform mutation.
- 5 instances undergo boundary mutation.
- 5 instances undergo non-uniform mutations.
- 3 instances undergo arithmetic crossover.
- 2 instances undergo uniform crossover.
- 5 instances undergo heuristic crossover.

V. FINITE ELEMENT GENETIC ALGORITHM AND B-SPLINE COMBINED TECHNIQUE

The numerical solution, which involves interaction between the B-spline function, the finite element model, and the Real Coded Genetic Algorithm (RCGA), progresses by conducting the following steps:

1. The design variables, which are the x and z-coordinates of the B-spline control points ($P_{i,j}$) and the thickness (t) of the shell wall, are randomly selected by the (RCGA) technique between the lower and the upper bounds of each design variable. Based on this random selection, a number of towers with different shape configurations and different shell wall thickness are created to form the initial population.
2. For each tower in the initial population, a three dimensional finite element model is developed based on the assumed geometry and shell wall thickness of this specific tower.
3. The finite element analysis is conducted to predict the structural response of the towers under the effect of design loads. The objective function $f(P_{i,j})$, which is set as the own weight of the tower, is then calculated.
4. Based on the results of the previous step, the feasibility of each tower is checked by applying the design, practicality and functionality constraints. In case of violating any of these constraints, the result of this specific tower is excluded by applying one or the entire penalty functions mentioned earlier. The chosen penalty function is added to the value of the objective function.
5. The initial population is sorted in an ascending order based on the value of the objective function, such that the first ranked candidate "tower" has the shape and the shell thickness that lead to lighter weight.
6. A new population of towers is generated by applying the (RCGA) cross over and mutation operators. These operators are applied on the high ranked towers evaluated in the previous step. They direct the search towards the global optimum solution.
7. The previous population is replaced with the newer one, which contains new candidates "towers" with better fitness.
8. Steps 3 to 7 are repeated for a certain number of generations until a global optimum solution is reached. In the current study, these steps are repeated for 40 generations to reach the optimum solution.

All previous steps are summarized in the flow chart shown in Fig. 6.

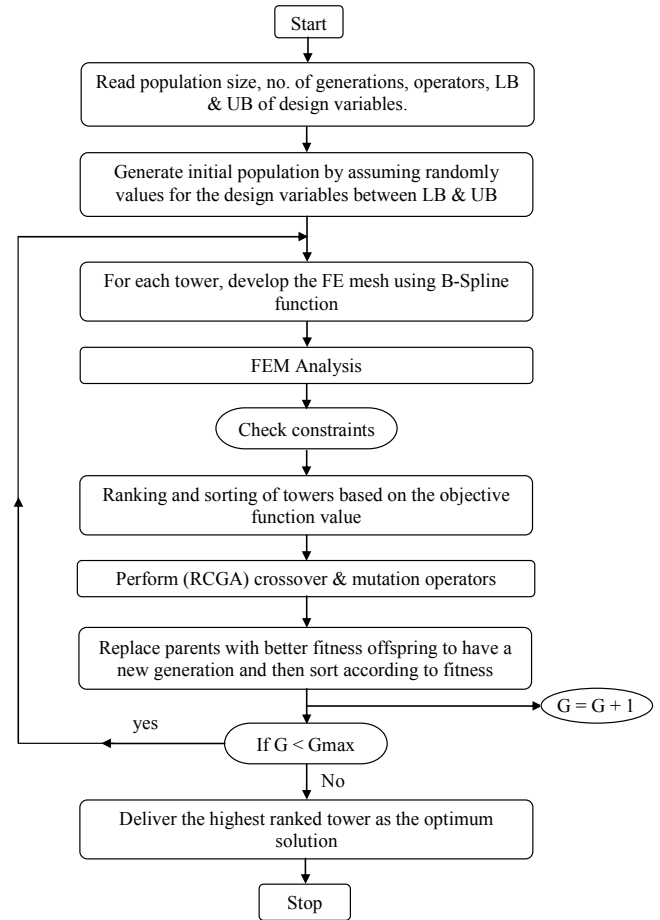

Fig. 6 Flow chart for optimum shape and design of cooling towers

VI. NUMERICAL RESULTS

Two analyses are conducted to illustrate the developed numerical tool. In the first, the design variables are restricted only to the x and z-coordinates of the control points, which specify the shape of the tower. The shell wall thickness is assumed to have the same thickness as the reference tower. In the second, the shell thickness (t) is added to the design variables in order to assess the effect of thickness variation on the shape and on the change of moments and forces acting on the shell wall. By introducing all design variables into the analysis, a reduction in the tower own weight is anticipated.

A. Results of Analysis 1-Optimum shape of Tower

The geometry of the reference tower, which is given in Table I, is plotted in Fig. 7. It is noticed that the slope of the meridian varies along the tower height with a maximum value of $\beta_s = 16^\circ$.

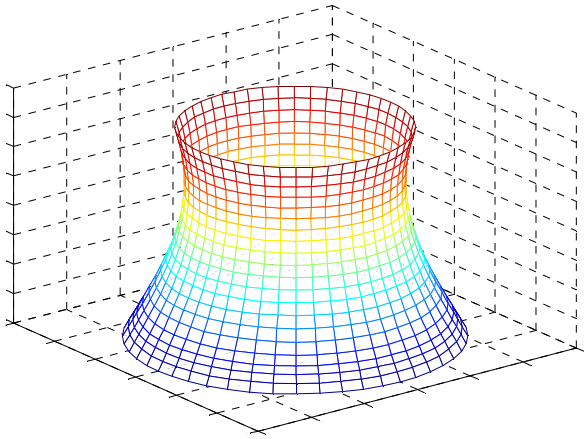

Fig. 7 Tower considered for comparison with thickness $t = 190\text{ mm}$

The optimum shape of the tower resulting from this optimization analysis is provided in Fig. 8. A minor change in the meridian shape with a maximum slope $\beta_s = 17^\circ$ is noticed.

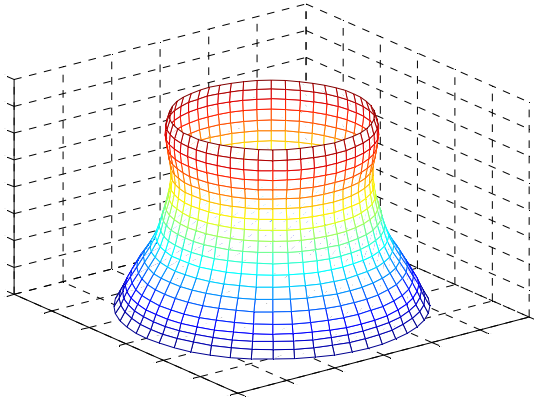

Fig. 8 Optimum shape with thickness $t = 190\text{ mm}$

The results show that a very minor difference in geometry is noticed between the two cases. In addition, it is noticed that the reduction in the tower own weight is negligible.

A comparison is conducted between the distributions of bending moments and meridional forces along the tower circumference for both cases. The maximum circumferential and meridional moments occur at the throat of the tower, while the maximum meridional forces occur at the shell base. Figs. 9 and 10 show the comparison between the reference and optimum cases for the moments and forces per unit length at the throat and the base of the tower, respectively. By reviewing these figures, it can be noticed that the optimum shape leads to a reduction in circumferential and meridional moments up to 26% and 25%, respectively. A minor reduction of 7.7% is noticed in case of meridional forces per meter acting at the shell base. This change in moments and forces is related to the change in the curvature of the shell surface. Finally, a general conclusion is drawn from this section that by assuming constant thickness $t = 190\text{ mm}$, the shape of the reference tower can be considered as an optimum or close to optimum.

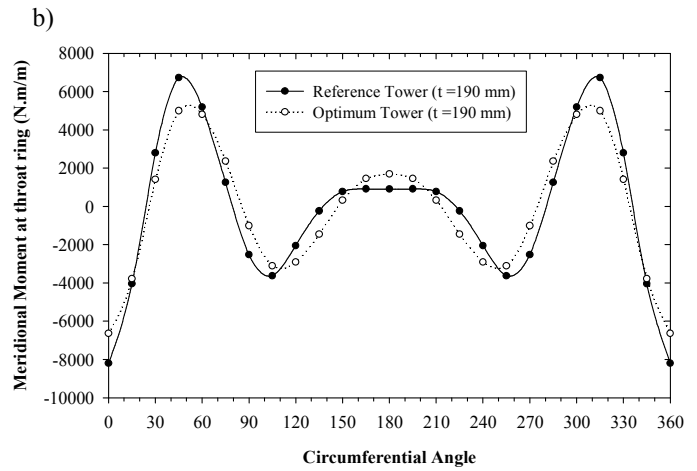
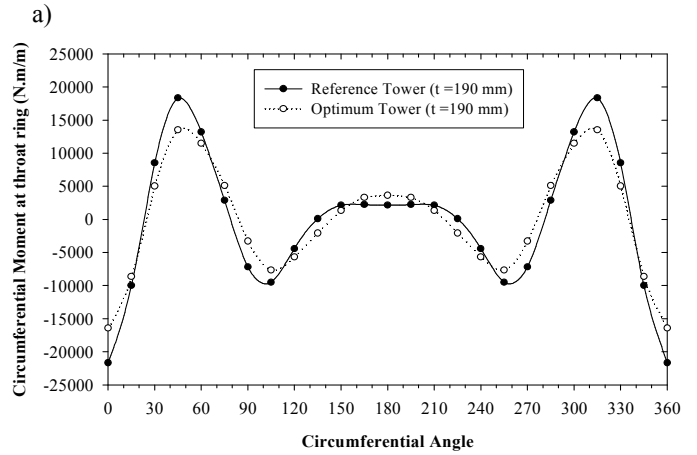

Fig. 9 Comparison between reference and optimum tower for case of moments

a) Circumferential moment b) Meridional Moment

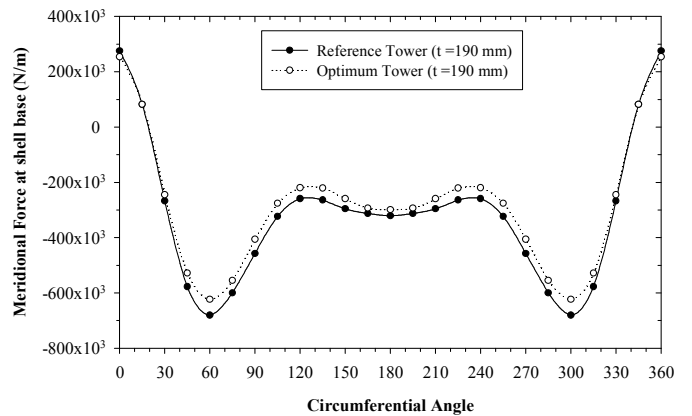

Fig. 10 Comparison between reference and optimum tower for case of forces

B. Results of Analysis 2-Optimum shape and thickness of Tower

Both the shape and the shell thickness are optimized in this analysis. Fig. 11 shows the optimum shape of the tower resulting from the analysis. The maximum value of the angle of inclination of the shell wall, reported in this analysis is $\beta_s = 19.5^\circ$. Details of the optimum geometry of the shell as well as the optimum shell thickness are provided in Table III.

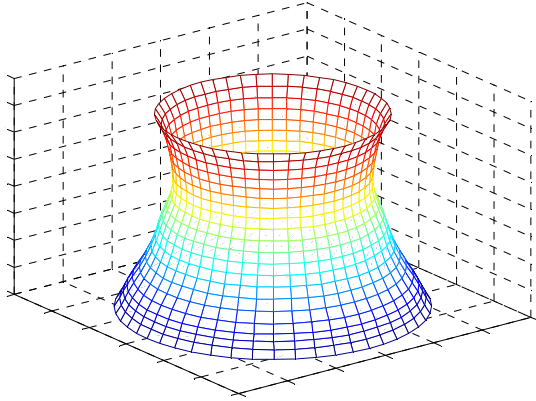

Fig. 11 Optimum shape with thickness $t = 165\text{ mm}$

TABLE III
OPTIMUM SHAPE AND THICKNESS OF TOWER

| Design Variable | Original tower | Optimum design | Difference (%) |
|-------------------------|----------------------|---------------------|----------------|
| $t\text{ (m)}$ | 0.19 | 0.165 | 13.16% |
| $r_1\text{ (m)}$ | 39.3 | 39.3 | 0.00% |
| $r_2\text{ (m)}$ | 37.9 | 37.7 | 0.53% |
| $r_3\text{ (m)}$ | 35.8 | 36.2 | 1.12% |
| $r_4\text{ (m)}$ | 32.5 | 32.1 | 1.23% |
| $r_5\text{ (m)}$ | 29.6 | 29.3 | 1.01% |
| $r_6\text{ (m)}$ | 27.4 | 27.7 | 1.09% |
| $r_7\text{ (m)}$ | 25.8 | 24.9 | 3.49% |
| $r_{Throat}\text{ (m)}$ | 25.1 | 24.8 | 1.20% |
| $r_8\text{ (m)}$ | 25.4 | 25.9 | 1.97% |
| $r_9\text{ (m)}$ | 26.5 | 27.2 | 2.64% |
| $r_{Top}\text{ (m)}$ | 27.4 | 29.3 | 6.39% |
| $W\text{ (KN)}$ | 107.87×10^3 | 94.06×10^3 | 12.8% |

Compared to the reference design, the results shown in the table indicate that the optimum solution involves a small change in the geometry. Meanwhile, a more significant change in the shell thickness from 190 mm to 165 mm is obtained. The combined reduction in the geometry and thickness of the shell reduces the own weight of the shell by 12.8%. It can be noticed that compared to the reference design, the radius of the throat of the tower is reduced by 1.2% while the radius of the top ring is increased by 6.4%.

Comparisons between the optimum solution and the reference tower are conducted in terms of bending moments and axial force distributions and are given in Figs. 12 and 13, respectively. It is noticed from these figures that reductions of 40% and 22% are achieved in the circumferential and

meridional moments, respectively. A similar reduction of 25% is achieved in the maximum meridional forces acting at the tower base.

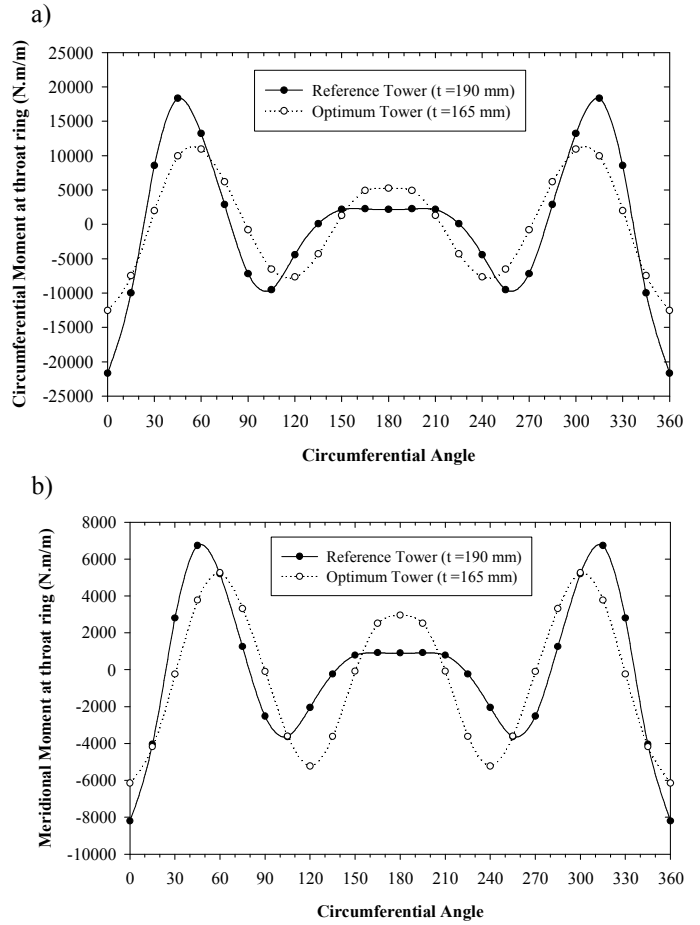

Fig. 12 Comparison between reference and optimum tower for case of moments

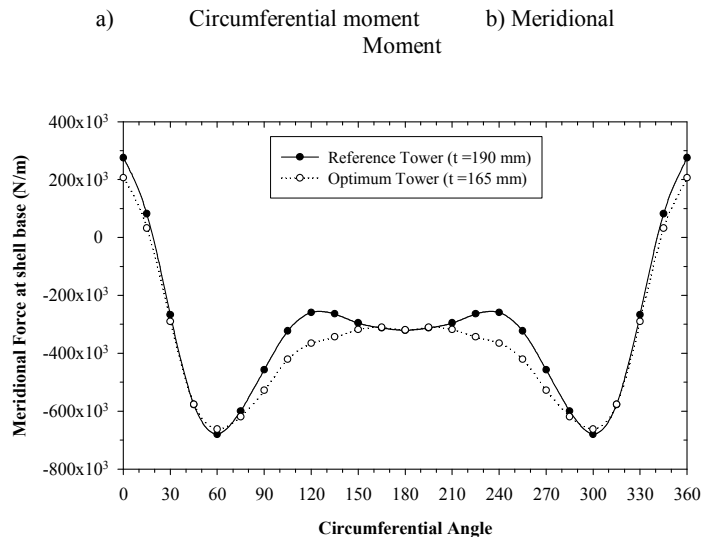

Fig. 13 Comparison between reference and optimum tower for case of forces

VII. PARAMETRIC STUDY

This section focuses on studying the effect of changing the constraint related to practicality requirements on the optimization results. The analysis is conducted by increasing the limit of the maximum slope β_L that can practically be adopted in the form-work. The slope β_L is assigned a value of 30° in the current analysis. Based on the new assigned value of this constraint, another optimum shape and optimum thickness are predicted. The optimum shape of the tower resulting from this analysis is provided in Fig. 14.

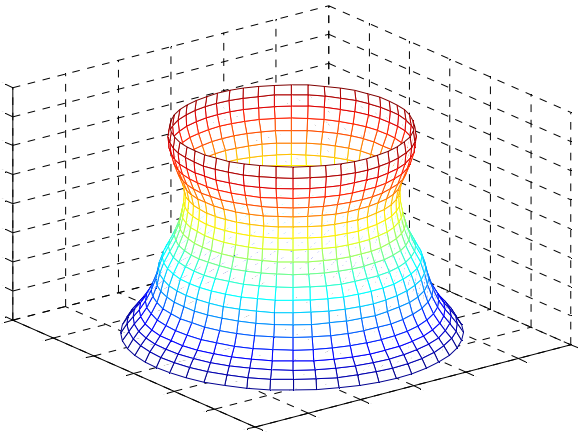

Fig. 14 Optimum shape of tower in case of $\beta_L = 30^\circ$

It is noticed from this figure that the slope of the meridian varies along the tower height, with a maximum slope of $\beta_s = 23.6^\circ$. In addition, it is noticed that the optimum shape of the tower differs from the hyperbolic shape. A comparison between the geometry of the reference tower and the optimum shape is presented in Table IV.

TABLE IV
OPTIMUM SHAPE AND THICKNESS OF TOWER IN CASE OF $\beta_L = 30^\circ$

| Design Variable | Original tower | Optimum design | Difference (%) |
|------------------|----------------------|---------------------|----------------|
| t (m) | 0.19 | 0.16 | 15.79% |
| r_1 (m) | 39.3 | 39.3 | 0.00% |
| r_2 (m) | 37.9 | 37.8 | 0.26% |
| r_3 (m) | 35.8 | 34.7 | 3.07% |
| r_4 (m) | 32.5 | 31.5 | 3.08% |
| r_5 (m) | 29.6 | 30.3 | 2.36% |
| r_6 (m) | 27.4 | 26.8 | 2.19% |
| r_7 (m) | 25.8 | 25.1 | 2.71% |
| r_{Throat} (m) | 25.1 | 24.4 | 2.79% |
| r_8 (m) | 25.4 | 27.2 | 7.09% |
| r_9 (m) | 26.5 | 28.9 | 9.06% |
| r_{Top} (m) | 27.4 | 28.0 | 2.19% |
| W (KN) | 107.87×10^3 | 91.16×10^3 | 15.5% |

This comparison shows that a reduction in the own weight of the tower of 15.5% is achieved, compared to the reference tower. The results of this analysis show that the increase in the maximum slope of the shell surface β_s , from 19.5° to 23.6° , leads to more reduction in the tower own weight.

VIII. SUMMARY AND CONCLUSIONS

A numerical tool that combines finite element analysis, geometric modeling with B-spline function, and real coded genetic algorithm (RCGA) is developed in this study. This numerical tool is used to predict the optimum shape of hyperbolic cooling towers. One of the main advantages of using the (RCGA) method is that it does not require guessing of a starting point to reach an optimum solution. In addition, the main advantages of using the B-spline function is that it provides greater flexibility in selecting the tower shape compared with the polynomial function. Two optimization analyses are conducted in the study for a cooling tower. The first involves optimizing the shape of the tower while assuming a fixed value for the shell thickness. In the second analysis both the shape and the thickness of the shell are optimized. The results are compared with a reference design for the tower that was previously conducted using typical analysis and design methods.

The following conclusions can be drawn from the first analysis:

1. By excluding the shell thickness from the set of design variables, the shape of the reference tower, which is hyperbolic, can be considered as an optimum or close to optimum.
2. Compared with the reference designed tower, the optimum shape of the tower leads to a reduction in circumferential and meridional moments up to 26% and 25%, respectively.
3. A minor reduction of 7.7% is noticed in case of meridional forces per unit length acting at the shell base.

The following conclusions are drawn from the second analysis:

1. The optimum shape and optimum shell thickness obtained from the proposed technique lead to about 12.8% reduction in the tower own weight compared to the reference designed tower. The shell thickness is reduced from 190 mm to 165 mm.
2. Reductions of 40% and 22% are achieved in the maximum circumferential and meridional moments, respectively. Similarly, a reduction of 25% is obtained in the maximum axial stresses acting at the base.

The following conclusions are drawn from the parametric study:

1. By increasing the maximum slope β_L that can practically be adopted in the form-work to 23.6° , optimum shape and optimum thickness that lead to a reduction of 15.5% in the own weight of the tower can be achieved, compared to the reference tower.

ACKNOWLEDGMENT

This work was made possible by the facilities of the Shared Hierarchical Academic Research Computing Network (SHARCNET: www.sharcnet.ca). A. M. El Ansary would like

to thank the financial support made by King Abdullah University of Science and Technology (KAUST) towards this publication.

REFERENCES

- [1] O.C. Zienkiewicz, J.C. Campbell, "Shape optimization and sequential linear programming", in: R.A. Gallagher, O.E. Zienkiewicz (Eds.), *Optimum Structural Design*, Wiley, New York, pp. 109-126, 1973.
- [2] C.V. Ramakrishnan, A. Francavilla, "Structural shape optimization using penalty functions", *J. Struct. Mech.* 3 (4), 403-422, 1975.
- [3] R.J. Yang, D.L. Dewhirst, J.E. Allison, A. Lee, "Shape optimization of connecting rod pin end using a generic model", *Finite element Analysis*. 257-264, 1992.
- [4] K.H. Chang, K.K. Choi, "A geometry-based parameterization method for shape design of elastic solids", *Mech. Struct. And Mach.* 215-252, 1992.
- [5] P.L. Gould, and S.L. Lee, "Bending of hyperbolic cooling towers", *J. Struct. Div. ASCE* 93 (ST5) 125-146, 1967.
- [6] J. Pieczara, "Optimization of cooling tower shells using a simple genetic algorithm", *Struct Multidisc Optim* 19, 311-316, 2000.
- [7] W. B. Kratzig, W. Zerna, "Resistance of hyperbolic cooling towers to wind and earthquake loading", In: Pister KS, editor. *Structural engineering and structural mechanics*. Englewood Cliffs, NJ: Prentice-Hall; P. 419-45, 1980.
- [8] ACI-ASCE Committee 334, "Recommended Practice for the Design and Construction of Reinforced Concrete Cooling Towers", *ACI J.*, 74(1), 22-31, 1977.
- [9] H. J. Niemann, "Wind effects on cooling-tower shells", *Journal of Structural Engineering, ASCE*; 106(3):643-61, 1980.
- [10] ASCE, "Minimum design loads for Buildings and other structures", ASCE 7-98, Reston, Va, 1999.
- [11] B. J. Vickery, J. Galsworthy, and A. A. El Damatty, BLWT-SS46-2007. "Wind loads and Interference effects for the cooling tower at the Cardinal #3 Plant", November, 2007.
- [12] A. M. El Ansary, "Optimum Design of Shell Structures" Ph.D. dissertation. The University of Western Ontario, London, Ontario, Canada. 2010.
- [13] L. Piegl, W. Tiller, "The NURBS book", Berlin, Heidelberg, New York:Springer, 1995.
- [14] B. Koziey, F. A. Mirza, "Consistent thick shell element", *Computers and Structures*, 65(12):531-41, 1997.
- [15] A. A. El Damatty, F. A. Mirza, R. M. Korol, "Large displacements extension of consistent shell element for static and dynamic analysis", *Computers and Structures*; 62(6):943-60, 1997.
- [16] D. E. Goldberg, "Genetic Algorithms in search", *Optimization and Machine Learning*. Addison-Wesley Publishing Company, Inc., New York, 1989.
- [17] L. Davis, *Handbook of Genetic Algorithms*, Van Nostrand Reinhold, New York, 1991.
- [18] P. L. Gould, W. B. Kratzig "Cooling tower structures", In: Chen W, editor. *Handbook of structural engineering*. Boca Raton, FL: CRC Press Inc. P. 473-504, 1998.
- [19] D. Busch, R. Harte, W. B. Kratzig, U. Montag, "New natural draft cooling tower of 200 m of height", *Eng. Struct.* 12;24(12):1509-21, 2002.
- [20] Z. Michalewicz, D. B. Fogel, "How to solve it: modern heuristics", 2nd Ed. New York, 2004.