

Sensorless Speed Based on MRAS with Tuning of IP Speed Controller in FOC of Induction Motor drive using PSO

Youcef Bekakra, Djilani Ben attous

Abstract—In this paper, a field oriented control (FOC) induction motor drive is presented. In order to eliminate the speed sensor, an adaptation algorithm for tuning the rotor speed is proposed. Based on the Model Reference Adaptive System (MRAS) scheme, the rotor speed is tuned to obtain an exact FOC induction motor drive. The reference and adjustable models, developed in stationary stator reference frame, are used in the MRAS scheme to estimate induction rotor speed from measured terminal voltages and currents. The Integral Proportional (IP) gains speed controller are tuned by a modern approach that is the Particle Swarm Optimization (PSO) algorithm in order to optimize the parameters of the IP controller. The use of PSO as an optimization algorithm makes the drive robust, with faster dynamic response, higher accuracy and insensitive to load variation. The proposed algorithm has been tested by numerical simulation, showing the capability of driving load.

Keywords—Induction motor drive, field oriented control, model reference adaptive system (MRAS), particle swarm optimization (PSO).

I. INTRODUCTION

INDUCTION motors have been widely used in high-performance ac drives, requiring ω information. Introducing a shaft speed sensor decreases system reliability, and different solutions for sensorless ac drives have been proposed. The MRAS speed estimators are the most attractive approaches due to their design simplicity [1].

The MRAS is based on principle, in which the outputs of two models –one independent of the rotor speed (reference model) and the other dependent (adjustable model)- are used to form an error vector. The error vector is driven to zero by an adaptation mechanism which yields the estimated rotor speed. Depending on the choice of output quantities that form the error vector, several MRAS structures are possible. The most common MRAS structure is that based on the rotor flux error vector which provides the advantage of producing rotor flux angle estimate for the field-orientation scheme [2]. The advantages of sensorless drives are clear: the mechanical setup and maintenance are less troublesome, and the reliability, especially in hostile environments, is improved if the

mechanical transducer is removed [3]. Field-oriented control (FOC) or vector control of induction machine achieves decoupled torque and flux dynamics leading to independent control of the torque and flux as for a separately excited DC motor. This control strategy can provide the same performance as achieved from a separately excited DC machine. This technique can be performed by two basic methods: direct vector control and indirect vector control. Both DFO and IFO solutions have been implemented in industrial drives demonstrating performances suitable for a wide spectrum of technological applications [4].

However control of IM is complicated due to the fact that in obtaining decoupled control of the torque and flux producing components of the stator phase current, both the magnitude and phase of the stator quantities need to be controlled. In addition, there is no direct access to the rotor quantities, such as rotor fluxes and currents. To overcome these difficulties, high performance vector control algorithms have been developed. These algorithms can decouple the stator phase currents by using only the measured stator current and flux, as well as the rotor speed [5]. This drive system has one speed IP controller which is tuned using PSO instead of traditional tuning methods; the drive system plays an important role in meeting the other requirements. It should enable the drive to follow any reference speed taking into account the effect of load and speed variation.

Particle swarm optimization (PSO) was first introduced by Kennedy and Eberhart in 1995 [6]. The method is based on the simulation of animal social behaviors such as fish schooling, bird flocking, and swarm theory. Since it is population based and self-adaptive, it has gained an increasing popularity as an efficient alternative to the genetic algorithm (GAs) in solving optimization problems. Moreover, it is shown to be effective in optimizing difficult multidimensional discontinuous problems in a variety of fields. Similar to other population-based optimization method such as the GA, the PSO algorithm starts with random initialization of a population of individuals in the search space. Each particle in the search space is adjusted by its own flying experience and the other particles flying experience to find the global best solution at each generation [7]. This paper presents online speed estimation procedure, based on MRAS scheme using only stator currents and voltages measurement, and we investigate the performance of PSO for optimizing the IP speed controller gains of the Induction Motor (IM) drive.

Y. Bekakra is with the Department of Electrical Engineering, El-Oued University Center, Algeria. (e-mail: youcef1984@gmail.com).

D. Ben Attous is with the Department of Electrical Engineering, El-Oued University Center, Algeria (e-mail: dbenattous@yahoo.com).

II. INDUCTION MACHINE MODEL

Using the dynamic model of an induction machine as a controlled plant may be expressed in terms of the d-q axes components in a synchronous rotating frame pre-sented in, the voltage equations in terms of stator current and rotor flux linkage can be restated in matrix form as [8]:

$$\begin{bmatrix} \frac{di_{sd}}{dt} \\ \frac{di_{sq}}{dt} \\ \frac{d\phi_{rd}}{dt} \\ \frac{d\phi_{rq}}{dt} \end{bmatrix} = \begin{bmatrix} -\left(\frac{R_s}{\sigma L_s} + \frac{1-\sigma}{\sigma T_r}\right) & \omega_s & \frac{M}{\sigma L_s L_r T_r} & \frac{M\omega_r}{\sigma L_s L_r} \\ -\omega_s & -\left(\frac{R_s}{\sigma L_s} + \frac{1-\sigma}{\sigma T_r}\right) & -\frac{M\omega_r}{\sigma L_s L_r} & \frac{M}{\sigma L_s L_r T_r} \\ \frac{M}{T_r} & 0 & -\frac{1}{T_r} & \omega_{sl} \\ 0 & \frac{M}{T_r} & -\omega_{sl} & -\frac{1}{T_r} \end{bmatrix} \times \begin{bmatrix} i_{sd} \\ i_{sq} \\ \phi_{rd} \\ \phi_{rq} \end{bmatrix} + \begin{bmatrix} \frac{1}{\sigma L_s} & 0 \\ 0 & \frac{1}{\sigma L_s} \\ 0 & 0 \\ 0 & 0 \end{bmatrix} \begin{bmatrix} V_{sd} \\ V_{sq} \end{bmatrix} \quad (1)$$

Where:

$$\sigma = 1 - \frac{M^2}{L_s L_r}; T_s = \frac{L_s}{R_s}; T_r = \frac{L_r}{R_r}; \omega_{sl} = \omega_s - \omega_r$$

The electromagnetic torque and the rotor speed are given by:

$$T_{em} = P \frac{M}{L_r} (\phi_{rd} i_{sq} - \phi_{rq} i_{sd}) \quad (2)$$

$$\frac{d\omega_r}{\omega_r} = \frac{P}{J} T_{em} - \frac{P}{J} T_l - \frac{f}{J} \omega_r \quad (3)$$

Where:

V_{sd} , V_{sq} , i_{sd} , i_{sq} , ϕ_{rd} and ϕ_{rq} are stator voltage, stator current and rotor flux d-q components in the rotor flux oriented reference frame; R_s , R_r are the stator and rotor resistances; L_s , L_r , M are the stator, rotor and mutual inductances; ω_s , ω_r , ω_{sl} are the synchronous, rotor and slip speed in electrical rad/s; T_{em} , T_l are the electromagnetic torque and the load torque respectively; P is number of pole pairs, J , f are the motor inertia and viscous friction coefficient respectively.

The position of field rotoric is determined by integration of the stator pulsation, it even reconstituted by the speed of the motor and the rotor pulsation [9]:

$$\theta_s = \int (\omega_r + \omega_{sl}) dt = \int \left(P \cdot \Omega + \frac{M \cdot i_{sq}}{T_r \phi_{rd}} \right) dt \quad (4)$$

III. THE STRUCTURE OF FIELD ORIENTED CONTROL

In the rotor field oriented control scheme, the rotor flux vector is aligned with the d-axis and it imposes the following condition [10]:

$$\phi_{rd} = \phi_r, \phi_{rq} = 0 \quad (5)$$

Thus by taking into account these new conditions and employing (5) on the (1), the dynamic model of an induction machine became:

$$V_{sd} = \sigma L_s \frac{di_{sd}}{dt} + \left(R_s + \frac{M^2}{T_r L_r} \right) i_{sd} - \omega_s \sigma L_s i_{sq} - \frac{M}{T_r L_r} \phi_r \quad (6)$$

$$V_{sq} = \sigma L_s \frac{di_{sq}}{dt} + \left(R_s + \frac{M^2}{T_r L_r} \right) i_{sq} + \omega_s \sigma L_s i_{sd} + \omega_r \frac{M}{L_r} \phi_r \quad (7)$$

$$\frac{d\phi_r}{dt} = \frac{M}{T_r} i_{sd} - \frac{1}{T_r} \phi_r \quad (8)$$

$$T_{em} = P \frac{M}{L_r} \phi_r i_{sq} \quad (9)$$

$$\omega_s = P \cdot \Omega + \frac{M \cdot i_{sq}}{T_r \phi_r} \quad (10)$$

A block diagram for a direct field oriented controller can be seen in the following section. This design uses a more robust structure known as direct FOC.

As can be seen in Figure 2 these map the three phase stator currents onto a direct and quadrature rotating reference frame that is aligned with the rotor flux. This decouples the torque and flux.

Producing components of the stator currents allows the induction motor to be controlled in much the same way as a separately excited DC machine. Three PI (Proportional Integral) and one IP (Integral Proportional) regulators are used to set the output reference voltages. The IP regulator compares the speed set point with the measured mechanical speed of the rotor and produces the stator current quadrature axis reference, i_{sq}^* . The PI regulator compares the rotor flux set point with the estimate rotor flux and produces the stator current direct axis reference, i_{sd}^* . To operate the motor above its nominal speed a technique known as Field Weakening is used to reduce the rotor flux. The reference currents are compared with the measured stator currents. The error is used by the PI regulators to generate the output stator voltages in the direct and quadrature axes. These are transformed back into the a, b and c axes using the inverse Park transformer to allow the output voltage to be generated directly using PWM.

IV. MRAS BASED ROTOR SPEED ESTIMATION

The MRAS technique is used in sensorless IM drives, at a first time, by Schauder. Since this, it has been a topic of many publications. The MRAS is important since it leads to relatively easy to implement system with high speed of

adaptation for a wide range of applications [11]. The basic scheme of the parallel MRAS configuration is given in Fig. 1. The scheme consists of two models; reference and adjustable (adaptive) ones and an adaptation mechanism. The block "Reference model" represents the actual system having unknown parameter values. The block "Adaptive model" has the same structure of the reference one, but with adjustable parameters instead of the unknown ones. The block "Adaptation mechanism" estimates the unknown parameter using the error between the reference and the adjustable models and updates the adjustable model with the estimated parameter until satisfactory performance is achieved.

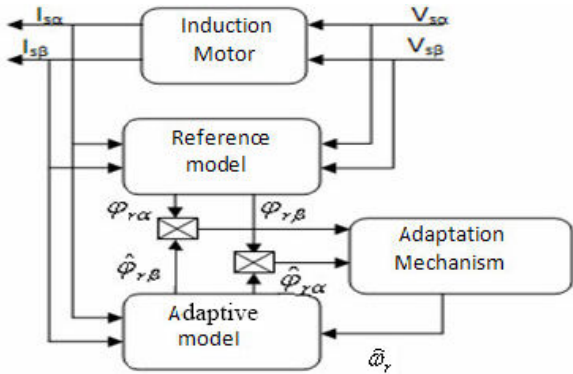

Fig. 1 MRAS speed observer

In this section we present the structure of the observer under study, which is based on the induction motor model written in stator frame [12].

The reference model is a model that doesn't depend on the rotation speed; it allows calculate the components of rotor flux from the equations of stator voltage:

$$\frac{d\phi_{r\alpha}}{dt} = \frac{L_r}{M} \left(V_{s\alpha} - R_s i_{s\alpha} - \sigma L_s \frac{di_{s\alpha}}{dt} \right) \quad (11)$$

$$\frac{d\phi_{r\beta}}{dt} = \frac{L_r}{M} \left(V_{s\beta} - R_s i_{s\beta} - \sigma L_s \frac{di_{s\beta}}{dt} \right) \quad (12)$$

The adaptive model is uses the speed of rotation in these equations and permits to estimate the components of rotor flux:

$$\frac{d\hat{\phi}_{r\alpha}}{dt} = -\frac{1}{T_r} \hat{\phi}_{r\alpha} - \hat{\omega}_r \hat{\phi}_{r\beta} + \frac{M}{T_r} i_{s\alpha} \quad (13)$$

$$\frac{d\hat{\phi}_{r\beta}}{dt} = -\frac{1}{T_r} \hat{\phi}_{r\beta} - \hat{\omega}_r \hat{\phi}_{r\alpha} + \frac{M}{T_r} i_{s\beta} \quad (14)$$

The adaptation mechanism compares the two models and estimates the speed of rotation by a Proportional Integral regulator.

Using Lyapunov stability theory, we can construct a mechanism to adapt the mechanical speed from the asymptotic convergence's condition of the state variables estimation errors.

$$\hat{\omega}_r = K_p (\hat{\phi}_{r\alpha} \phi_{r\beta} - \phi_{r\alpha} \hat{\phi}_{r\beta}) + \int K_i (\hat{\phi}_{r\alpha} \phi_{r\beta} - \phi_{r\alpha} \hat{\phi}_{r\beta}) dt \quad (15)$$

K_p and K_i are positive gains.

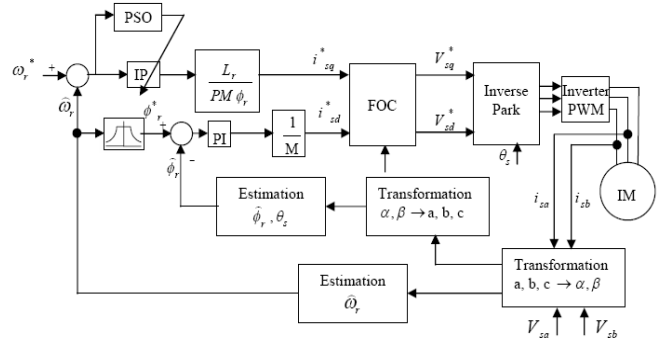

Fig. 2 Sensorless Direct field oriented control of induction motor with PSO

V. DESIGNING OF IP-CONTROLLER USING PSO

The PSO as an optimization tool provides a population-based search procedure in which individuals called particles change their position (state) with time. In a PSO system, particles fly around in a multidimensional search space. During flight, each particle adjusts its position according to its own experience (This value is called P_{best}), and according to the experience of a neighboring particle (This value is called G_{best}), made use of the best position encountered by itself and its neighbor [13] (see Figure 3).

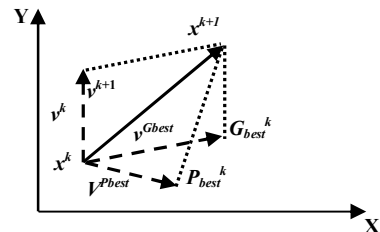

Fig. 3 Concept of a searching point by PSO

This modification can be represented by the concept of velocity. Velocity of each agent can be modified by the following equation:

$$v^{k+1} = w v_k + c_1 \text{rand} * (P_{best} - x^k) + c_2 \text{rand} * (G_{best} - x^k) \quad (16)$$

Using the above equation, a certain velocity, which gradually gets close to P_{best} and G_{best} can be calculated. The current position (searching point in the solution space) can be modified by the following equation:

$$x^{k+1} = x^k + v^{k+1}, \quad k = 1, 2, \dots, n \quad (17)$$

Where, x^k is current searching point, x^{k+1} is modified searching point, v^k is current velocity, v^{k+1} is modified velocity. p_{best} is the best solution observed by current particle and g_{best} is the best solution of all particles, w is an

inertia weight, c_1 and c_2 are two positive constants, rand is a random generated numbers with a range of [0,1].

The following inertia weight is used [13]:

$$w(k) = w_{max} - \left(\frac{w_{max} - w_{min}}{k_{max}} \right) * k \quad (18)$$

Where k_{max} , k is maximum number of iterations and the current number of iterations, respectively. where, w_{min} and w_{max} are the minimum and maximum weights respectively. Appropriate value ranges for c_1 and c_2 are 1 to 2, but 2 is the most appropriate in many cases. Appropriate values for w_{min} and w_{max} are 0.4 and 0.9 [14] respectively.

The IP-controller is a good controller in the field of machine control, but the problem is the mathematical model of the plant must be known. In order to solve problems in the overall system, several methods have been introduced to tune IP-controller. Our proposed method uses the PSO to optimize the speed IP-controller parameters, the PSO is utilized on-line to determine the controller parameters (K_p and K_i) based on speed error of the IM shown Fig. 2. The performance of the IM varies according to IP controller gains and is judged by the value of *ITAE* (*Integral Time Absolute Error*). The performance index *sum(ITAE)* is chosen as objective function. The purpose of stochastic algorithms is to minimize the objective function. All particles of the population are decoded for K_p and K_i .

ITAE criterion is widely adopted to evaluate the dynamic performance of the control system [15]. The index *ITAE* is expressed in equation (19), as follows:

$$ITAE = \int_0^{\infty} t \cdot |e(t)| dt \quad (19)$$

The PSO-based approach to find the global maximum value of objective function as shown in Fig. 4.

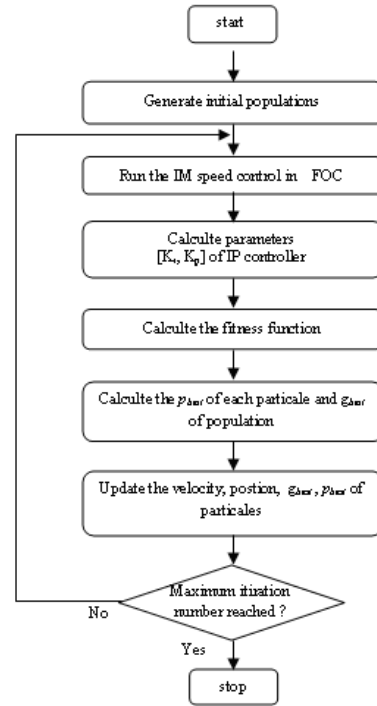

Fig. 4 The flowchart of the PSO-IP control system

VI. SIMULATION RESULTS AND DISCUSSION

The IM used in this work is a 1.08 KW, whose nominal parameters are indicated in appendix.

The parameters of PSO algorithms are showed in Table I.

TABLE I
PARAMETERS OF PSO ALGORITHMS

Swarm size	15
Number of iteration	20
$c_1 = c_2$	2
w_{max}	0.9
w_{min}	0.4

The motor drive is operated at 157 rad/s under no load and a load disturbance torque (5 N.m) is suddenly applied at t=0.6s and eliminated at t=0.8s, followed by a consign (100 rad/s) at t=1s, also a load disturbance torque (5 N.m) is suddenly applied at t=1.6s and eliminated at t=1.8s, followed by a low consign (30 rad/s) at t=2s, finally, a load disturbance torque (5 N.m) is suddenly applied at t=2.6s.

With the results we can estimate the rotor speed in the different working of high speeds to low speeds as shown in Fig. 5.

It is clearly shown from the results that the input reference is tracked by the actual and estimated speed and the introduced of disturbance is rapidly rejected by the control

system because the optimization of the gains of IP controller by PSO.

The speed error or estimated error (Fig. 6 calculated from the difference between speed with sensor (real speed) and speed without sensor (estimated speed) remain weak and bellow ± 0.02 rad/s.

During the variation of the speed, the results shows that this variation lead to the variation in flux and the torque (see Fig. 7 and 8). The response of the system is positive, the speed follow its reference value while the torque return to its reference value with a little error.

The Fig. 9 shows the phase stator current. The stator current in the induction motor remains sinusoidal during this condition operating.

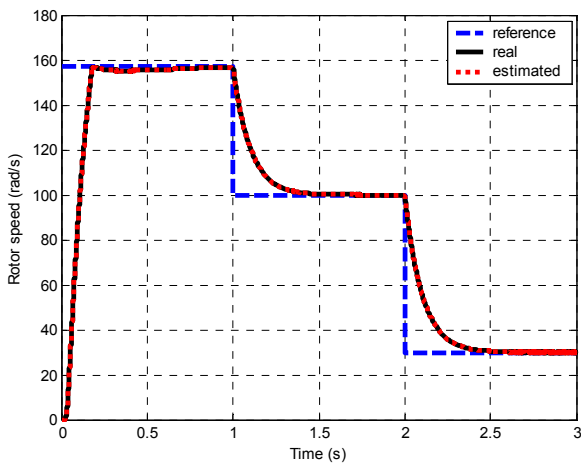

Fig. 5 Simulation results actual and estimated speed using MRAS with PSO

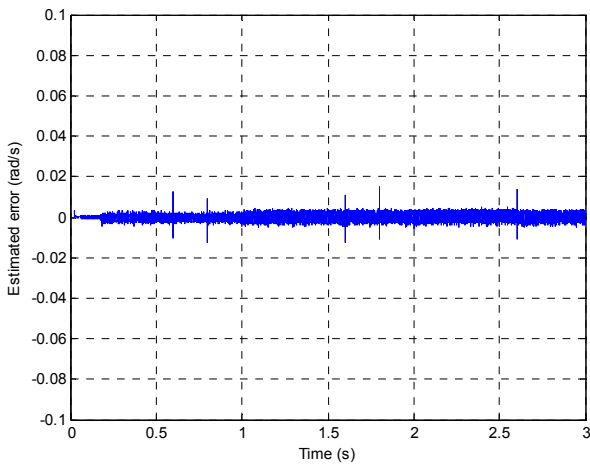

Fig. 6 Rotor speed estimation errors using the MRAS with PSO

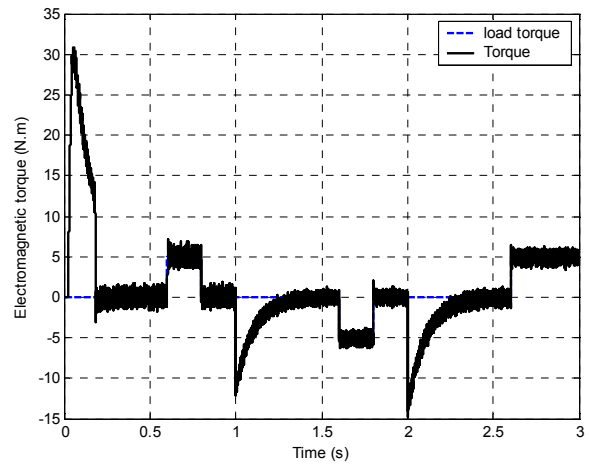

Fig. 7 The electromagnetic and load torque for varied targets

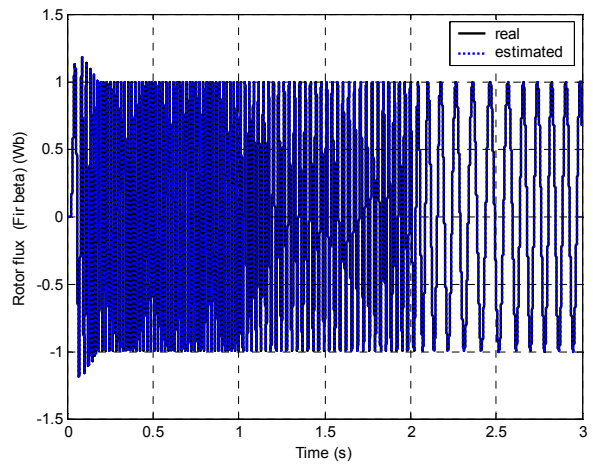
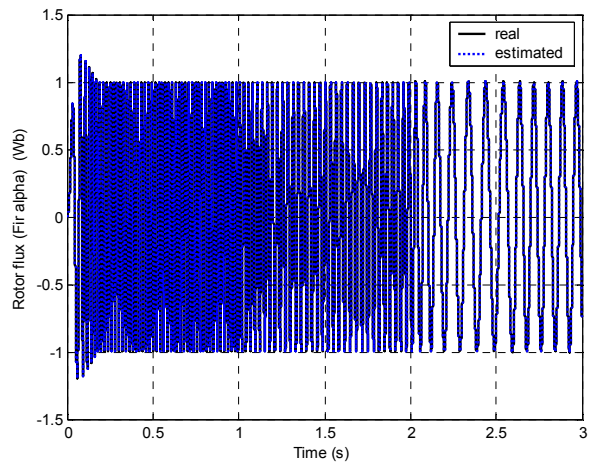

Fig. 8 The actual and estimated rotor flux linkages

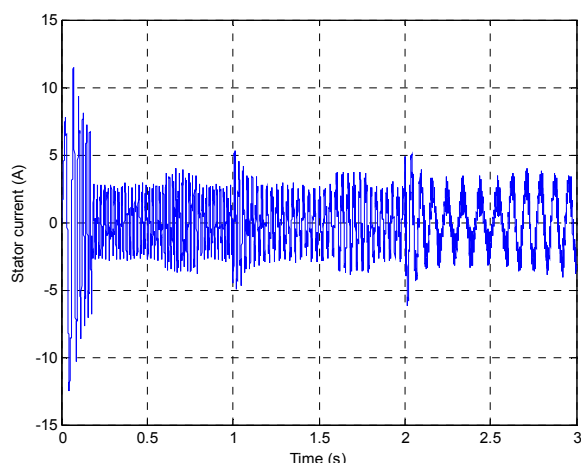

Fig. 9 Phase stator current

VII. CONCLUSION

This paper presented a speed sensorless control algorithm of induction motor drive based on MRAS with tuned the gains of the IP speed controller by an intelligent method PSO. The MRAS technique was used to provide a real-time adaptive estimation of the motor speed. The swarm optimizer is used to adapt the IP controller parameters. The practical modifications were carried out to implement the speed estimation and the validity with effectiveness of the proposed adaptation algorithm are verified by simulation results, it show a better performance in the estimated speed where the estimated error is very small, also the system is stable face the speed variation and the applied and elimination the load torque.

APPENDIX

Rated values: 1.08 KW; 220/380; 50 Hz; 2.83A / 4.91 A, 1500 rpm.

Rated parameters: $R_s = 10 \Omega$, $R_r = 6.3 \Omega$, $L_s = 0.4642 \text{ H}$, $L_r = 0.4612 \text{ H}$, $M = 0.4212 \text{ H}$, $P = 2.0$, $J = 0.01 \text{ Kg.m}^2$, $f = 0.00 \text{ N-m/rad}$.

REFERENCES

- [1] V. Vasic, S. Vukosavic, "Robust MRAS-based algorithm for stator resistance and rotor speed identification," *IEEE Power Engineering Review*, pp. 39-41, Nov. 2001.
- [2] S. Meziane, R. Toufouti, H. Benalla, "MRAS based speed control of sensorless induction motor drives," *ICGST-ACSE Journal*, Vol. 7, Issue 1, pp. 43-50, May 2007.
- [3] Y. Agrebi, M. Triki, Y. Koubaa, M. Boussak, "Rotor speed estimation for indirect stator flux oriented induction motor drive based on MRAS scheme," *Journal of Electrical Systems*, Vol. 3, No 3, pp. 131-143, 2007.
- [4] I. K. Bousserhane, A. Hazzab, M. Rahli, B. Mazari, M. Kamli, "Position control of linear induction motor using an adaptive fuzzy integral – backstepping controller," *Serbian Journal of Electrical Engineering*, Vol. 3, No. 1, pp. 1-17, June 2006.
- [5] A. S. Elwer, "A novel technique for tuning PI-controllers in induction motor drive systems for electric vehicle applications," *Journal of Power Electronics*, Vol. 6, No. 4, pp. 322-329, Oct. 2006.
- [6] J. Kennedy, R. Eberhart: "Particle swarm optimization", *IEEE Transactions*, pp. 1942-1948, 1995.

- [7] F. J. Lin, L. T. Teng, J. W. Lin, and S. Y. Chen, "Recurrent functional-link-based fuzzy-neural-network-controlled induction-generator system using improved particle swarm optimization," *IEEE Transactions on Industrial Electronics*, Vol. 56, No. 5, pp. 1557-1577, May 2009.
- [8] A. Chaari, M. Soltani, M. Gossa, "Comparative study between the conventional regulators and fuzzy logic controller: application on the induction machine," *International Journal of Sciences and Techniques of Automatic control & computer engineering IJ-STA*, Vol. 1, No 2, pp. 196-212, Dec. 2007.
- [9] A. Mechernene, M. Zerikat and M. Hachlef, "Fuzzy speed regulation for induction motor associated with field-oriented control," *International Journal of Sciences and Techniques of Automatic control & computer engineering IJ-STA*, Vol. 2, No 2, pp. 804-817, Dec. 2008.
- [10] A. BEN ALI, A. KHEDHER, M. F. MIMOUNI, R. DHIFAOUI "Torque maximization and sensorless control of induction motor in a flux weakening region," *International Journal of Sciences and Techniques of Automatic control & computer engineering IJ-STA*, Vol. 3, No 1, pp. 972-985, July 2009.
- [11] M. MESSAOUDI, H. KRAIEM, M. BEN HAMED, L. SBITA and M. N. ABDELKRIM, "A robust sensorless direct torque control of induction motor based on MRAS and extended kalman filter," *Leonardo Journal of Sciences*, Issue 12, January-June 2008, pp. 35-56.
- [12] A. Abbou and H. Mahmoudi, "Performance of a sensorless direct torque flux control strategy for induction motors associated to the three levels NPC converter used in electrical vehicles," *International Journal of Sciences and Techniques of Automatic & computer engineering IJ-STA*, Vol. 2, No 2, pp. 790-803, Dec. 2008.
- [13] M. PADMA LALITHA, V. C. VEERA REDDY, V. USHA, "Optimal DG placement for minimum real power loss in radial distribution systems using PSO," *Journal of Theoretical and Applied Information Technology*, pp. 107-116, 2010.
- [14] R.C Eberhart. and Y. Shi, "Comparing inertial weights and constriction factor in particle swarm optimization," in *Proceeding of the International Congress on Evaluation and Computation*, pp. 84-88, 2000.
- [15] B. ALLAOUA, B. GASBAOUI, B. MEBARKI, "Setting up PID DC motor speed control alteration parameters using particle swarm optimization strategy," *Leonardo Electronic Journal of Practices and Technologies*, Issue 14, January-June 2009, pp. 19-32.