

Experimental Investigation of S-Rotors in Open and Bounded Flows

Hussain H. Al-Kayiem and Goh Jin Ming

Abstract—The common practice of operating S-rotor is in an open environment; however there are times when the rotor is installed in a bounded environment and there might be changes in the performance of the rotor. This paper presents the changes in the performance of S-rotor when operated in bounded flows. The investigation was conducted experimentally to compare the performance of the rotors in bounded environment against open environment. Three different rotors models were designed, fabricated and subjected to experimental measurements. All of the three models were having 600 mm height and 300 mm Diameter. They were tested in three different flow environments; namely: partially bounded environment, fully bounded environment and open environment. Rotors were found to have better starting up capabilities when operated in bounded environment. Apart from that, all rotors manage to achieve higher Power and Torque Coefficients at a higher Tip Speed Ratio as compared to the open environment.

Keywords—Bounded Flows, Savonius Rotor, Wind Turbine, Wind energy, VAWT

I. INTRODUCTION

EVER since the worldwide energy crisis, people around the world has move out to search for alternative and renewable energy sources. Wind energy has become a particularly interesting field for scientist and engineers to work in. Savonius rotor in particular has gained much attention due to the fact that is simpler to build, has good starting capabilities and low operating speed. The common practice of operating a Savonius rotor is in an open environment; however there are times when the rotor is fixed in a bounded environment and the performance of rotor might differ.

Menet and Bouraba [1] have carried out experimental study on the traditional Savonius rotor and suggested an optimum geometrical parameter whereby a two step rotor, with end plate radius 10% larger than blade radius, and height of the rotor is 4 times the size of the blade radius and primary overlapping of 0.15-0.30 of the diameter of blades.

Kamoji and Kedare [2] have studied a modified Savonius rotor design to investigate the power coefficient and torque coefficient. The parameters that of concern are overlap ratio, blade arc angle, aspect ratio and Reynolds number. The optimum configuration of modified blade geometry was overlap ratio equals to zero, aspect ratio of 0.7, blade arc

angle of 124° and end plate parameters of 1.1 produce highest coefficient of power.

A study was conducted by Irabo and Roy [3] to improve and adjust the output power of Savonius rotor under various wind power and to prevent rotor from strong wind disaster. They found out that the guide box tunnel is capable of increasing the rotor rotational speed and hence the value of output efficiency is higher compared to Savonius rotor without guide box tunnel. The research showed that operation of Savonius rotor in bounded flows is capable in improving the performance.

Research work was reported by Mohamad *et al* [4] on optimization of Savonius turbines using an obstacle shielding the returning blade. Considerable increase in the self starting capability of the Savonius rotor was achieved. The negative torque region was completely eliminated with the introduction of obstacle shielding plate

Altan and Atilgan [5] conducted a study on the use of curtaining to increase the performance level of Savonius rotor. The reason being that, the curtain helps to direct the flow of wind into the concave blade and also to prevent a negative torque created as the wind hit the convex blade. The experimental and numerical analysis of the research results have led to optimum alignment of curtain for the best performance of the rotor.

Continual efforts are being made to investigate possible means to improve the power coefficient and efficiency and optimization of Savonius rotor. Most of the studies were carried out experimentally, (e.g. [6,7, and 8]), while very few were conducted by analytical and numerical simulation, (e.g. [9 and 10]).

The objective of the present work is to experimentally investigate the performance of S-rotors in open and bounded flows in terms of power coefficient and torque coefficient. For that, three different types of S-rotors were designed, fabricated and subjected to experimental measurement. The performance was characterized by evaluating the power and torque coefficients. Also, the starting speed was observed since it represents important operation factor in the practical use of the wind turbines.

II. EXPERIMENTAL IMPLEMENTATION

The analysis technique adopted for this project is experimental investigation. The concept of Savonius rotor design in this experiment is based on the optimum geometrical parameter suggested by [1], whereby a two step rotor, with end plate radius 10% larger than blade radius, and height of the rotor is 4 times the size of the blade radius and primary overlapping of 0.15-0.30 of the diameter of blades.

Three different models of S-rotors were fabricated; two different test rigs for operation in bounded flows were fabricated namely partially bounded and fully bounded

Hussain H. Al-Kayiem Author , is with Universiti Teknologi PETRONAS, Bandar Seri Iskandar, 31750 Tronoh, Perak, Malaysia (Tel: +605 368 7008| 6, Fax: +605-365 6461, (e-mail hussain_kayiem@petronas.com.my)

Goh Jin Ming Author is with Universiti Teknologi PETRONAS, Bandar Seri Iskandar, 31750 Tronoh, Perak, Malaysia (e-mail: jming88@gmail.com)

casings. Tools and equipments required for the project are torque meter, portable vane anemometer, digital tachometer and portable industrial fans. AutoCAD is used for the drawings of Savonius rotors and test rigs. Microsoft Excel is utilized for tabulating data and results calculations.

A. Rotors Design and Fabrication

Three different rotors were designed and fabricated, namely Rotors 1, 2 and 3. Rotor 1 is the conventional Savonius rotor. Rotor 2 is based on the geometrical parameter recommended in the literature review, namely, [2], while Rotor 3 is entirely new design. Rotor's design criteria such as end plate size, overlapping between blades and aspect ratio are based on optimum values recommended by [1]. All rotors are standardized to two steps rotor, 600 mm in total height, 300 mm in diameter and 330 mm for end plate diameter.

• Rotor 1

By referring to Fig. 1, the blade diameter, d is 175 mm and the overlap between the blades is 50 mm. The total height for the two steps rotor is 600 mm.

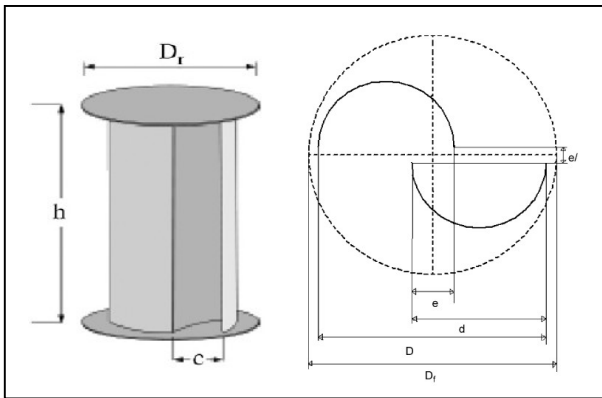

Fig. 1 Schematic Drawing of rotor 1

• Rotor 2

By referring to Fig 2, ψ is determined to be 130° based on recommendation of [2], m is taken to be 45 mm. The primary overlap, e is taken to be 22.5mm, r and p are 90 mm and 18 mm, respectively.

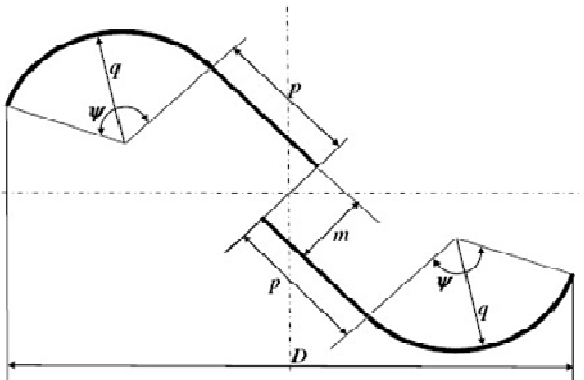

Fig. 2 Schematic drawing of rotor 2

• Rotor 3

Referring to Fig 3, center shaft diameter is set to be 20 mm, height of rotor is 600 mm, and straight length for blade is 130 mm and 90° curvatures with 15 mm radius. A total of eight blades with 45° apart between each other, each blade have a height of 110 mm and offset between each blade is 39.4 mm

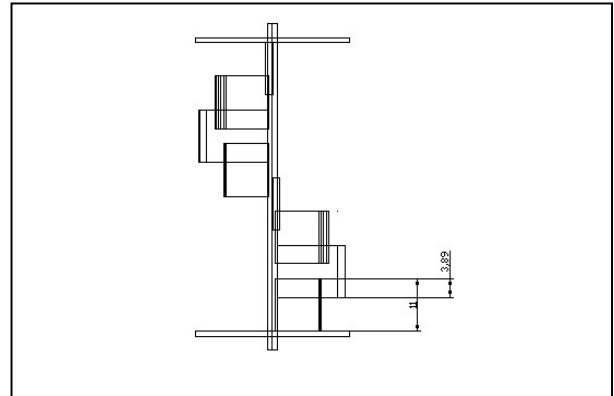

Fig. 3 Schematic Drawing of rotor 3

B. Fabrication of Rotors

Each rotor blade is fabricated using 1mm thickness aluminum sheets, the end plates are made from acrylic glass with 6 mm thickness top and bottom, and middle plates have a thickness of 4mm each. The rotors are assembled using super strength glue and industrial Ebstik glue. The top and bottom protruding shafts are made from mild steel with a diameter for 10 mm. Fig 4 shows the three fabricated rotors.

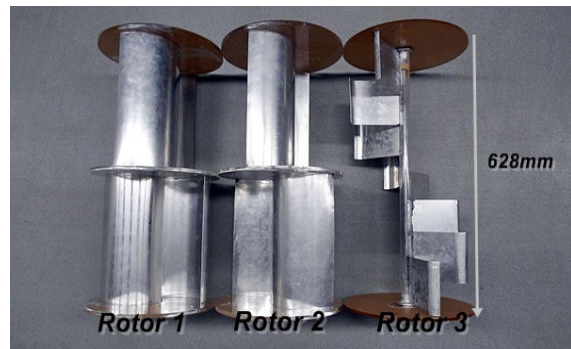

Fig. 4 Fabricated Rotor 1, 2 and 3

C. Test Rig Design and Fabrication

Two different test rigs are design and fabricated for bounded flow operations. Test rigs are named as partially bounded and fully bounded test rig. Partially bounded test rigs allows wind to hit on both the concave and convex area of the blades, while fully bounded test rig shield the convex area and only allows wind to hit on the concave area of blade. The test rigs are made from 2mm thickness mild steel sheets and is fabricated using methods such as bending, rolling cutting and welding. Both test rigs are 675 mm in height, 1000 mm in length and 300 mm opening width for partially bounded casing and 174 mm opening width for fully bounded casing.

Both test rigs have a 340 mm holes in the middle to allow inserting of rotors. Fig. 5 and Fig. 6 show the fabricated partially bounded and fully bounded test rigs.

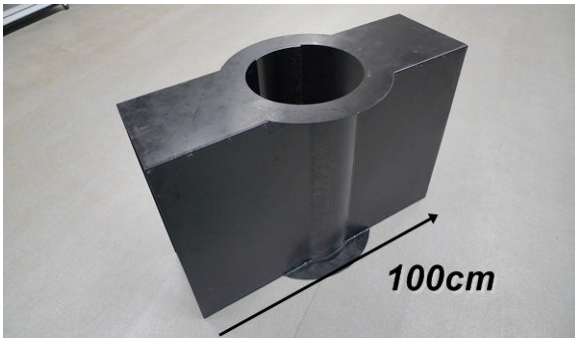

Fig. 5 Partially Bounded Test Rig

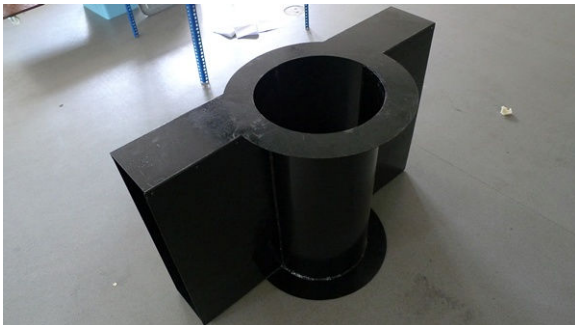

Fig. 6 Fully Bounded Test Rig

D. Experimental Set Up and Procedures

For the experiment, an industrial fan with 700 mm in diameter is used as the wind source. The fixture is made from pivoted angle bars standing at 1120 mm tall, 800 mm width and 800 mm in length. The rotors are held by a specially design bush at both ends and is fixed to the fixture using steel girders by bolts and nuts. The wind source is placed as closed to the fixtures as possible to reduce loses of strength in the wind source, the distance between the fixture to the fan is approximately 300 mm, reason being for the tolerance is due to allocation for the 1 meter in length test rig later on when placed onto the fixture. A dimmer switch is fixed to the industrial fan to regulate the desire wind speed for the experiment.



Fig. 7 Experiment Set Up

A wind speed of 1m/s to 7 m/s is desired and achieved by regulating the dimmer switch attached to the industrial fan. The wind speed was measured by using a vane anemometer at 3 different spots namely top, middle and bottom closest to the fixtures, due to the nature of the wind from the industrial fan, the wind speed will not be constant at all spots, instead an average will be taken, a tolerance of ± 0.2 m/s is acceptable for the wind average. The rotational speed, ω in RPM, of the rotor resulting from the wind speed will be measured by a digital tachometer. A reflective strip is stick at the top plate of the rotor, and the measurement is taken by pointing the laser tip of the tachometer onto the reflective strip. Measurement will only be taken when the turning of the rotor stabilizes, three different readings will be taken each time, and the average will be considered. The torque, T in N.m, produce by the rotor due to the wind speed is measured using a torque meter by clamping it to the shafts. Since the torque is fluctuating due to the turning of rotor, the maximum will be taken and three measurements will be taken and the average will be considered.

III. RESULTS AND DISCUSSION

The formulas use for the calculation of Power Coefficient and Torque Coefficient are as below:

$$C_p = P_{rotor} / P_{wind} \quad (1)$$

$$P_w = \frac{1}{2} \rho V^3 A_{rotor} \quad (2)$$

$$P_{rotor} = \omega \cdot T \quad (3)$$

Where, ρ is the density of air, V is the wind speed from the source, A_{rotor} is the area of the diameter of the blades times the height of the rotor. ω is the revolution of the rotor and T is the torque generated by the rotor.

Torque Coefficient, C_T

$$C_T = T / (1/2 \rho V^3 A_{rotor} (D/2)) \quad (4)$$

Where T is the measured torque generated by the rotor and D is the diameter of the rotor.

The results are presented in terms of C_p and C_T versus the Tip Speed Ratio, TSR, which is:

TSR= Rotor Tip Speed/wind speed

A. Open Flow Results

Fig. 8 shows the result of Power Coefficient versus Tip Speed Ratio, TSR for Rotor 1, 2 and 3. The maximum Power Coefficient for Rotor 1 is 0.42 at TSR of 0.9231. For Rotor 2, the maximum Power Coefficient is 0.083 at TSR of 0.326. Lastly for Rotor 3, the maximum coefficient is 0.0368 occurs at TSR of 0.3. From the results shown above, it can be clearly determine that Rotor 1 has the best Power Coefficient followed by Rotor 2 and Rotor 3.

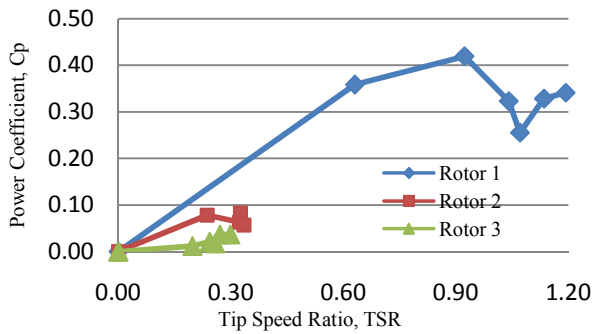

Fig. 8 Comparison of Power Coefficient of the Rotors for Open operation

As could be noticed in Fig 9, maximum torque for Rotor 1, 2 and 3 happens at TSR equals to zero, the maximum torque for Rotor 1 is 0.34 and for Rotor 2 and 3 both is 0.12. The torque decreases as TSR increases, from the graph Rotor 1 has better torque coefficient compare to Rotor 2 and Rotor 3. Rotor 1 performs much better as compared to Rotor 2 and 3.

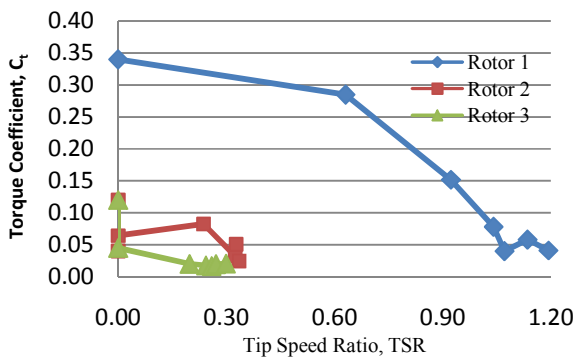

Fig. 9 Comparison of Torque Coefficient of the Rotors in Open Operation

There are several factors that contribute to the low performance of Rotors 2 and 3. The main contributor would be the rotor designs, unlike Rotor 1. Rotor 1 curves from the tip and has a straight at end, and the design allows wind to pass through when hitting the concave blade without follow up to push the second blade. For rotor 3, the curvature at the tip might not be enough to capture the wind, unlike Rotor 1 and 2; it has much smaller radius at the curvature and longer straights at the end. Other causes could be due to weight, abrasion in bearings and assembly mistake.

B. Rotor 1 Results

From Fig 10, Rotor 1 achieves the highest power coefficient at partially bounded environment, with a C_p of 0.5219 at TSR of 1.019. Follow suit is operation in open environment with a C_p of 0.42 at TSR of 0.923. Lastly is operation in fully bounded environment with a C_p of 0.4162 at TSR of 1.043. In general the C_p increases in bounded flow operations for Rotor 1, highest C_p is achieved at a range of TSR from 0.8 to 1.2.

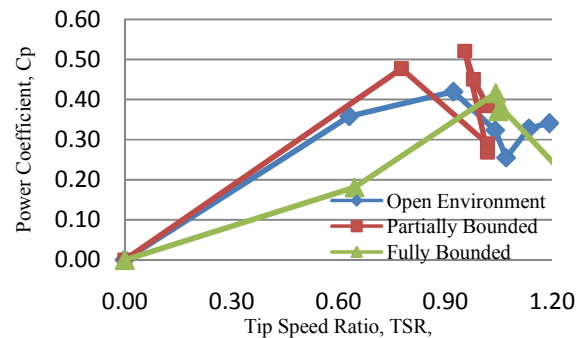

Fig. 10 Cp Results for Rotor 1 at different Operating Environments

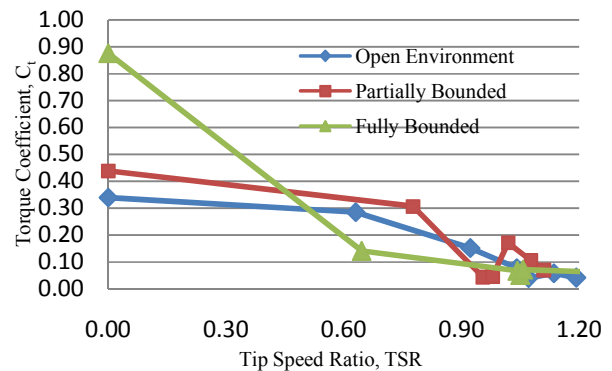

Fig. 11 C_T Results for Rotor 1 at different Operating Environments

Fig 11 shows the Torque coefficient for Rotor 1 in different operating environments. The maximum torque coefficient is achieved when TSR is equals to zero. The maximum torque coefficient is achieved by operating Rotor 1 in fully bounded environment where C_T equals to 0.876. For operation in partially bounded environment C_T is 0.44 and lastly for open environment is 0.34. If comparing TSR at a range from 0.6 to 1.2, operation in partially bounded flow is much better comparing to fully bounded and open environment.

Operation in fully bounded casing does not performs as well predicted, however Rotor 1 appears to be operating better at partially bounded environment, and C_p is much higher comparing to other operating environments and C_T appears to be higher comparing to fully bounded casing when Rotor 1 operated at TSR from 0.60-1.20. The reason for lower performance in fully bounded casing might due to the smaller opening of wind inlet as compare to partially bounded casing, certain amount of wind from the fan might be blocked. However do note that for fully bounded casing, Rotor 1 is capable in operating at higher TSR.

C. Rotor 2 Results

Fig 12 shows the comparison of C_p between different operating environments for Rotor 2. For Rotor 2, the maximum Power Coefficient is achieved by operating in fully

bounded environment, where C_p equals to 0.16 at TSR of 0.54. The maximum C_p for partially bounded environment is 0.1 at TSR of 0.296. Lastly the maximum C_p for open environment is 0.083 at TSR of 0.326. With the use of fully bounded casing Rotor 2 is able to achieve higher TSR and C_p . In general the use of casing in Rotor 2 increases the C_p of Rotor 2.

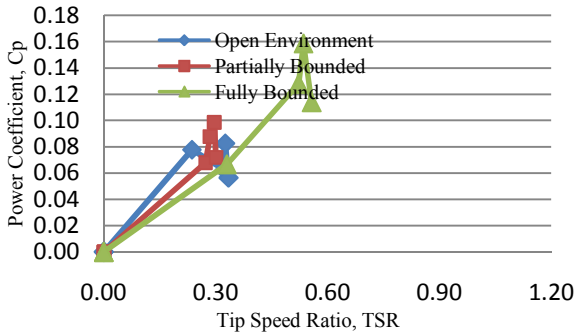

Fig. 12 C_p Results for Rotor 2 at different Operating Environments

On Fig 13 is the Torque coefficient comparison between operating environments for Rotor 2. Maximum C_T is 0.635 at TSR of 0 in fully bounded environment. The torque coefficient then decreases with the increase in TSR. For open environment, the maximum C_T is 0.12 when TSR is zero. The maximum torque for partially bounded environment is 0.1995 when TSR is zero. Fully bounded environment is better when TSR is zero to achieve higher torque coefficient, however when operated at a TSR range of 0.20 to 0.35, open environment and partially bounded environment has better C_T , 0.082 and 0.077 each. However, for fully bounded operation, Rotor 2 is capable in achieving higher TSR and torque coefficient.

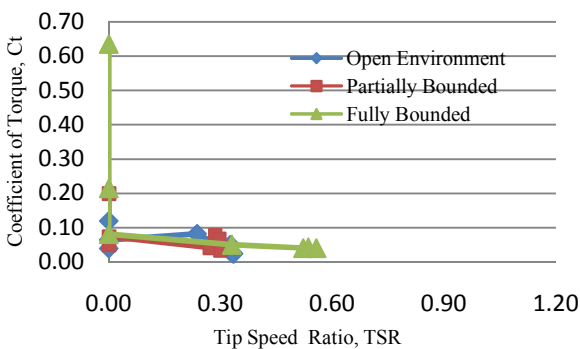

Fig. 13 C_T Results for Rotor 2 at different Operating Environments

D. Rotor 3 Results

From Fig. 14, the maximum C_p for Rotor 3 is 0.058 at TSR of 0.425 operating under fully bounded environment. For open environment, the maximum C_p is 0.037 at TSR of 0.3. Under operation of partially bounded environment the maximum C_p is 0.033 at TSR of 0.24. With the operation of fully bounded environment, Rotor 3 is capable of achieving

higher C_p at higher TSR. If compare the range of TSR between 0-0.25, it can be seen that under operation in partially bounded environment the C_p increases as compared to open environment.

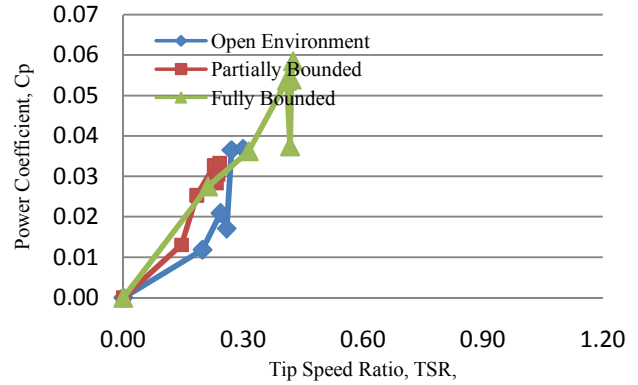

Fig. 14 C_p Results for Rotor 3 at different Operating Environments

Fig. 4 is showing the C_T comparison between operating environments for Rotor 3. Highest C_T is 0.24 at TSR of zero for fully bounded environment. For partially bounded environment maximum C_T is 0.18 at TSR of zero. Lastly for open environment maximum C_T is 0.12 at TSR of zero. With operation in fully bounded environment, higher C_T can be achieved, as well as higher TSR.

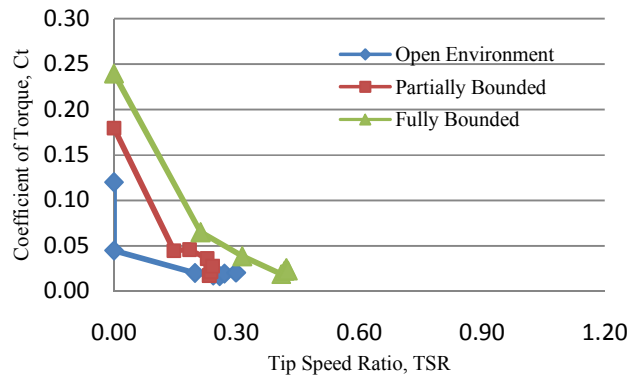

Fig. 15 C_T Results for Rotor 3 at different Operating Environments

E. Remarks on the starting up

The starting capabilities of the three rotors were found to be improved with operation in bounded environment. All of the rotors were started to rotate at lower wind speed when the flow is bounded. For operation in open environment, Rotor 1 start turning at 2.7 m/s without any need of torque to start up, while Rotor 2 starts turning at approximately 4 m/s, Rotor 3 starts turning at approximately 3m/s. Under the operation of partially bounded environment, Rotor 1 starts turning at 1.7 m/s and Rotor 2 starts at 3.4 m/s, lastly Rotor 3 is capable to start at approximately 2m/s. For fully bounded environment, Rotor 1 starts at approximately 2m/s and Rotor 2 starts approximately 3.4 m/s, lastly Rotor 3 manage to start at 1.8 m/s. The current experimental work was conducted using

industrial fan as the wind source and the wind speed is regulated by a regulator from 1 m/s to 7 m/s. The maximum wind speed from the industrial fan is 7 m/s, it is recommended to run the experiment using a wind tunnel with a better range of wind speed up to 15m/s. The reason that wind tunnel is not being used, is due to the downtime of wind tunnel, over heating on the motor and the long waiting list Always repeat the experiment at least three times to ensure the consistency of result obtained.

IV. CONCLUSION

Three different S-rotors were designed and fabricated utilizing the recommendations of previous researchers. Rotor 1 represents the conventional Savonius rotor design. Rotor 2 is a modified Savonius rotor with a straight end and curve tip, while Rotor 3 is a newly design wind rotor with no reference available so far. All three rotors were subjected to experimental measurement at three different flow configurations; free flow, partially bounded flow, and fully bounded flow. The conclusions drawn from the experiment results are as below:

The *starting capabilities* of the Rotors are improved with operation in bounded environment. The three were started to rotate at lower wind speed when installed in bounded flow environment.

In general, there is enhancement in the *power coefficient* for all rotors when operated in bounded flow environment as compared to open environment. With the operation in bounded environment, Rotors are capable in achieving higher TSR as compared to open environment. Rotor 1 achieved maximum $C_p=0.52$ under partially bounded operation, while Rotor 2 and 3 achieved better C_p when operated in fully bounded environment.

Higher *torque coefficient* is achieved when the rotors operated in bounded environment. For Rotor 1, highest C_T of 0.876 is achieved when operated in partially bounded environment, for Rotor 2 and 3; highest C_T is achieved when operated in fully bounded environment.

From the results of the experiment, it is possible to conclude that the performance of the rotors could be enhanced with the operation in bounded flow environment.

It is recommended to improve the wind source in the experiment to achieve more uniform wind distribution in front of the rotors models, and also to increase the wind speed to about 15 m/s. Also, further investigations are essential on improved/modified designs of Rotor 3 with difference in blade curvature.

ACKNOWLEDGMENT

The authors acknowledge Universiti Teknologi PETRONAS for the financial support to perform the project under the HES-MOR budget. Also, thanks are due to the RIO for the financial and technical support to present the paper in ICEESD2011.

REFERENCES

[1] J.L. Menet and N. Bourabaa, N "Increase in The Savonius Rotor Efficiency via Parametric Investigation", France..

- [2] M.A. Kamoji , S.B. Kedare, and S.V. Prabhu , 2009, "Experimental investigations on single stage modified Savonius rotor", India, Applied Energy, 86, 1064–1073
- [3] K Irabu and J. N. Roy, 2007, "Characteristics of wind power on Savonius rotor using a guide-box tunnel", Japan, Experimental Thermal and Fluid Science, 32, 580–586.
- [4] M.H. Mohamed, G. Janiga, E. Pap, and D. Thévenin; 2010, "Optimization of Savonius Turbines Using an Obstacle Shielding the Returning Blade", Germany, Renewable Energy, 35, 2618-2626.
- [5] B.D. Altan , and M Atilgan, 2008, "An experimental and numerical study on the improvement of the performance of Savonius wind rotor", Turkey, Energy Conversion and Management, 49, 3425–3432
- [6] V.J. Modi and MSUK Fernando, 1989; "On the performance of the Savonius wind turbine". JSol Energy Eng, 111:71–81.
- [7] U.K. Saha , S. Thotla, and D. Maity ; 2008, "Optimum design configuration of Savonius rotor through wind tunnel experiments", India, Journal of Wind Engineering and Industrial Aerodynamics, 96, 1359- 1375.
- [8] U.K. Saha and M. Jaya Rajkumar On the performance analysis of Savonius rotor with twisted blades, Renewable Energy 31 (2006) 1776–1788.
- [9] H.H. Al-Kayiem & A. E Sa'ad Al-Deen,, Performance Analysis of Savonius Wind Rotor for Directed Flow Operation. Proceedings of the 1st Engineering Conference (EnCon), December 27-28, Kuching, Sarawak, Malaysia, 2007.
- [10] B. K. Debnath, A Biswas, and R Gupta, Computational Fluid Dynamic analysis of combined three-bucket Savonius and three-bladed Darries Rotors at various overlap conditions, Journal of Renewable and Sustainable Energy 1.0033110, 033110-1-13(2009).