

Optimization of Quantization in Higher Order Modulations for LDPC-Coded Systems

M.Sushanth Babu, P.Krishna, U.Venu and M.Ranjith

Abstract—In this paper, we evaluate the choice of suitable quantization characteristics for both the decoder messages and the received samples in Low Density Parity Check (LDPC) coded systems using M-QAM (Quadrature Amplitude Modulation) schemes. The analysis involves the demapper block that provides initial likelihood values for the decoder, by relating its quantization strategy of the decoder. A mapping strategy refers to the grouping of bits within a codeword, where each m -bit group is used to select a $2m$ -ary signal in accordance with the signal labels. Further we evaluate the system with mapping strategies like Consecutive-Bit (CB) and Bit-Reliability (BR). A new demapper version, based on approximate expressions, is also presented to yield a low complexity hardware implementation.

Keywords—Low Density parity Check, Mapping, Demapping, Quantization, Quadrature Amplitude Modulation

I. INTRODUCTION

LOW DENSITY PARITY CHECK (LDPC) codes are state-of-art error correcting codes, included in several standards for broadcast transmissions. Iterative soft-decision decoding algorithms for LDPC codes reach excellent error correction capability. Great attention has been paid, in recent literature, to the topic of quantization for LDPC decoders, but mostly focusing on binary modulations and analyzing finite precision of the receiver.

The LDPC error correcting code has gained immense attraction over turbo codes in second generation satellite transmission of digital television (European Telecommunication Standards Institute (ETSI)) and has already been proposed for the next generation digital terrestrial television standards (Digital Video Broadcasting (DVB))[1]. Modern telecommunication standards, often adopt high order modulation schemes, e.g. M-QAM, with the aim to achieve large spectral efficiency [2].

Mr.M.SUSHANTH BABU is research scholar at Jawaharlal Nehru Technological University and working as Associate Professor in Vaagdevi College of Engineering. (Phone: +91-9849299910, Email: sushanth_6@yahoo.com).

Mr.P.KRISHNA is research scholar at Jawaharlal Nehru Technological University and working as Assistant Professor in Vaagdevi College of Engineering. (Phone: +91-9963309062, Email: kpatteti@gmail.com).

Mr.U.VENU is presently working as Assistant Professor in Vaagdevi College of Engineering. (Phone: +91-9908863650, Email: uvenu404@gmail.com).

Mr.M.RANJIT is presently working as Assistant Professor in Vaagdevi College of Engineering. (Phone: +91-9866117934, Email: ranjitmarri@gmail.com).

The aim of the paper is to study the effect of uniform and non-uniform quantization in SISO and reduce the complexity of the decoder with suitable approximations.

The organization of the paper is as follows. In Section II we describe the system model. We provide detail theoretical analysis of both Encoder and Decoder of LDPC with Tanner graph, in Section III. Section IV we describe the quantization for Irregular LDPC with Bit reliability Mapping Strategies. Section V provides different approximation strategies to reduce Look up table size. Finally, Section VI Second order approximation of Demapper is analyzed. Section VII concludes the paper.

II. SYSTEM MODEL

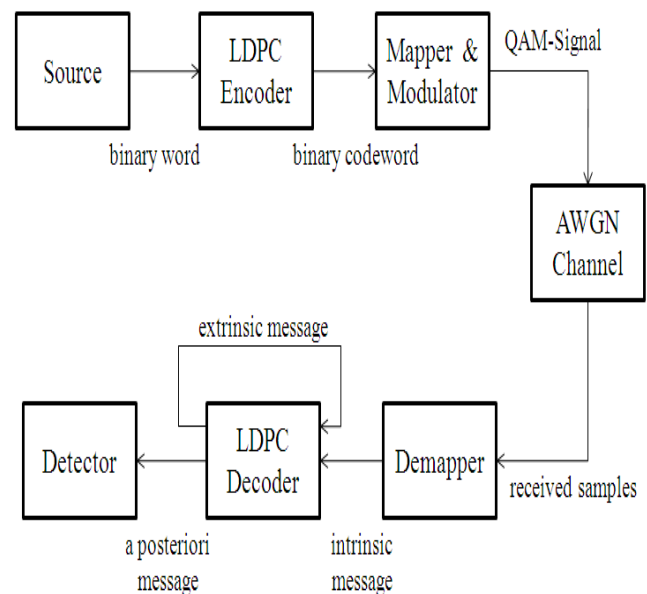

Fig. 1 Block diagram of a LDPC-coded system

The Fig. 1 depicts the general block diagram of a communication system with higher order modulation. The LDPC encoder maps each k -bit word produced by the source into an n -bit LDPC codeword. Each codeword is then passed to the mapper and modulator block, that transforms groups of $t = \log_2^M$ code bits into a symbol of the bi-dimensional M-QAM constellation. The modulated signal is then transmitted over an Additive White Gaussian Noise (AWGN) channel. At the receiver side, the demapper block works as Maximum A-Posteriori (MAP) symbol-to-bit metric calculator, that is able to produce an initial likelihood value for each received bit. These

messages serve as input for the Sum-Product Algorithm (SPA), that starts iterating and, at each iteration, produces updated versions of the extrinsic and the a posteriori messages [3] which are further used as input for the subsequent iteration (if needed), which represents the decoder output, and serve to obtain an estimated codeword that is subject to the hard decision and the parity-check test.

III. LOW DENSITY PARITY CHECK CODES

A. Construction of G

A generator matrix G is used for constructing the code. The generator matrix may be found from the parity check matrix H. First we note that

$$H_x = X^T H^T \tag{1}$$

The code word x may be split into one information part i and one parity check part c. The code word may then be Written as

$$X^T = [i/c] \tag{2}$$

Correspondingly, the parity check matrix may be split into two matrices:

$$H = [A/B] \tag{3}$$

From (1), we note that vector i is multiplied with matrix A, whereas vector c is multiplied with matrix B.

$$Ai + Bc = 0 \tag{4}$$

If the matrix B is non-singular, (4) may be inverted and the check bits c may be found from (5)

$$c = B^{-1}Ai \tag{5}$$

In practice, it may be necessary to swap over some of the columns in H in order to become non-singular matrix B and the product B⁻¹A makes out the generator matrix G. This matrix is calculated once and used for all encoding. The parity check matrix is used for constructing a graph structure in the decoder.

B. Graph Structure

The decoding of LDPC codes may be efficiently performed through the use of a graph structure. In this work, Tanner graphs will be used for the decoding [4]. The graph is constructed from the parity check matrix H. Each row in the matrix is represented by a check node, whereas each 1 in the row is represented by an edge into a bit node. Each column is represented by a bit node, and each 1 in the column corresponds to an edge into a check node. This is illustrated in Fig. 2 and Fig. 3. In this manner, a graph is constructed which contains a total of N bit nodes and M check nodes. The numbers of edges are decided by the number of 1's in the parity check matrix. All edges are connected to a check node and to a bit node. The number of edges connected to a node denotes the degree of the node.

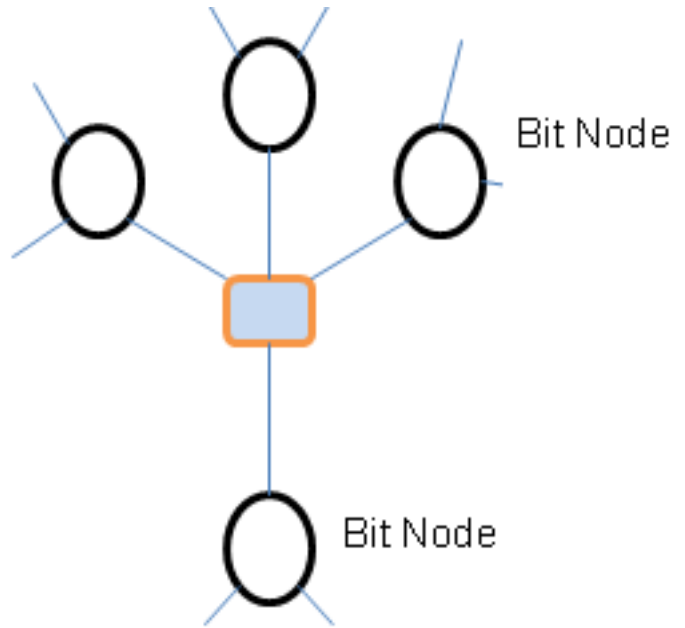

Fig. 2 Check Nodes.

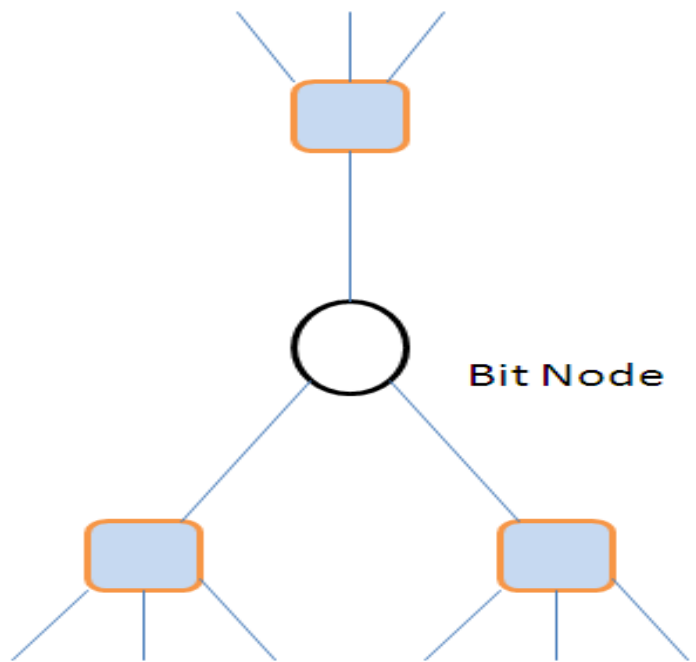

Fig. 3 Bit Nodes.

C. Decoding

In this context, the decoder is soft-decision input decoder, implying that it operates on the channel symbols, denoted by

$$r = 2x - 1 + n \tag{6}$$

Where n is the AWGN noise vector added in the channel and x is the code word. Finding the probability of the parity of a vector is a central concept in the decoding of LDPC codes. Each parity check may be regarded as vector of even parity [5]. First, we define the Likelihood Ratio (LR) as the ratio between the two probabilities P(x = 1) and P(x = 0):

$$LR = \frac{P(x = 1)}{P(x = 0)} \tag{7}$$

The symbol λ is used for the Log Likelihood Ratio,

$$\lambda = \frac{P(x = 1)}{P(x = 0)} \tag{8}$$

If x is a vector of bits and the LLR of a bit i in that vector is given by λ_i

$$\lambda_i = \frac{P(x_i = 1)}{P(x_i = 0)} \tag{9}$$

The notation $\Phi(x)$ is used for the vector parity. The LLR of the parity of the vector x is then given by:

$$\lambda_{\Phi(x)} = \frac{P(\Phi_x = 1)}{P(\Phi_x = 0)} \tag{10}$$

$\lambda_{\Phi(x)}$ Can be computed with (10)

$$\tanh\left(\frac{-\lambda_{\Phi(x)}}{2}\right) = \prod_{i=1}^n \tanh\left(\frac{-\lambda_i}{2}\right) \tag{11}$$

Equation (11) is modified with respect to $\lambda_{\Phi(x)}$:

$$\lambda_{\Phi(x)} = -2 \tanh^{-1}\left(\prod_{i=1}^n \tanh\left(\frac{-\lambda_i}{2}\right)\right) \tag{12}$$

The posteriori LLR of a bit n is given by:

$$\lambda_n = \log \frac{P(x_n = 1/r)}{P(x_n = 0/r)} \tag{13}$$

The vector r may be split into two parts: r_n refers to the systematic part of the code word, and $\{r_{i \neq n}\}$ refers to the parity bits:

$$\lambda_n = \log \frac{P(x_n = 1/r_n, \{r_{i \neq n}\})}{P(x_n = 0/r_n, \{r_{i \neq n}\})} \tag{14}$$

Where, Bayes rule is given by:

$$p(a/b) = \frac{P(b,a)}{P(b)} \tag{15}$$

We use this rule in order to re-express the numerator of (14)

$$P(x_n = 1/r_n, \{r_{i \neq n}\}) = \frac{f(r_n, x_n = 1\{r_{i \neq n}\})}{f(r_n, \{r_{i \neq n}\})} \tag{16}$$

Further simplification based on the equality

$$p(a/b) = \frac{P(b,a)}{P(b)}$$

$$P(x_n = 1/r_n, \{r_{i \neq n}\}) = \frac{f(r_n/x_n = 1\{r_{i \neq n}\})f(x_n = 1, \{r_i \neq n\})}{f(r_n/\{r_{i \neq n}\})f(\{r \neq n\})} \tag{17}$$

$$\text{Where, } f(r_n/x_n) = \frac{1}{\sqrt{2\pi\sigma^2}} e^{-\frac{(r_n - 2x_n + 1)^2}{2\sigma^2}} \tag{18}$$

$$\text{and } \lambda_n = \frac{2}{\sigma^2} r_n + \log \frac{P[x_n = 1, \{r_i \neq n\}]}{P[x_n = 0, \{r_i \neq n\}]} \tag{19}$$

If the parity of a vector x is 0 (even parity), the probability that a bit x_n is 1, given the received values of the rest of the vector $r_i \neq n$, is the same as the probability that the rest of the vector $\{r_i \neq n\}$ has odd parity.

$$\lambda_n = \frac{2}{\sigma^2} r_n + \log \frac{P[\Phi_{(i)} = 1 \text{ for } i = 1 \dots j / \{r_{i \neq n}\}]}{P[\Phi_{(i)} = 0 \text{ for } i = 0 \dots j / \{r_{i \neq n}\}]} \tag{20}$$

If the vectors $x_1, x_2, x_3, \dots, x_j$ are independent and $\{r_i \neq n\}$, then

$$\lambda_n = \frac{2}{\sigma^2} r_n + \log \frac{\prod_{i=1}^j P[\Phi_{(i)} = 1 / \{r_{i \neq n}\}]}{\prod_{i=1}^j P[\Phi_{(i)} = 0 / \{r_{i \neq n}\}]} = \frac{2}{\sigma^2} r_n + \sum_{i=1}^j \log \frac{P[\Phi_{(i)} = 1 / \{r_{i \neq n}\}]}{P[\Phi_{(i)} = 0 / \{r_{i \neq n}\}]} = \frac{2}{\sigma^2} r_n + \sum_{i=1}^j \lambda_{\Phi(x_{i_i})} \tag{21}$$

In the graph, $\lambda_{i,l}$ is the message (contribution) from bit node i to check node l :

$$\lambda_{i,l} = \log \frac{P[\Phi_{(i)} = 1 / \{r_{i \neq n}\}]}{P[\Phi_{(i)} = 0 / \{r_{i \neq n}\}]} \tag{22}$$

and the expression for LLR for n^{th} bit can be simplified as

$$\lambda_n = \frac{2}{\sigma^2} r_n - 2 \sum_{i=1}^j \tanh^{-1}\left(\prod_{l=2}^k \tanh\left(\frac{-\lambda_{i,l}}{2}\right)\right) \tag{23}$$

In the above equation first intrinsic message is added to previously calculate extrinsic message from j vector, which consists of n bits.

IV. BIT RELIABILITY MAPPING STRATEGY

An irregular LDPC is characterized by degree of distribution pair (λ_i, ρ_j) , where λ_i is the fraction of edges connected to variable nodes with degree i and ρ_j is the fraction

of edges connected to check nodes with degree j . Different variable node degrees imply different reliabilities after decoding. One way to explain this is to first note that the degree of a variable node is equal to the number of ones in the corresponding column of the code's parity-check matrix H . The column of a parity-check matrix can be considered to be a repetition code with the number of ones corresponding to the number of repetitions.

For M -ary modulation, we transmit m bits, $(c_{m-1} \dots c_1, c_0)$, in different levels (or "bit planes"). Bits transmitted at different levels are protected differently. The LSB level has the weakest protection than MSB. Based on this knowledge, we propose a Bit-reliability mapping strategy. We map the less reliable LDPC code bits to the lower level modulation bits and the more reliable bits to the higher level bits.

V. QUANTIZATION OF THE RECEIVED SIGNALS

The effect of the quantization on the input received samples can be related, through a simple analytical approach of decoder message quantization. An estimate of the number of quantization bits for the input signals m_s can be easily found that is compatible with the resolution d_e adopted for the messages, to further avoid the performance degradation.

A. Estimation of the Maximum Quantization Error

Once having obtained x_q and y_q , as the results of an analog-to-digital conversion, these values are used to calculate the $f_k(x_q, y_q, \sigma)$ for each set of codeword bits ($k=1, \dots, 4$, in the considered 16-QAM). Noting by $2T_s$ the dynamic range of the input x and y ($T_s=4$) and by m_s the number of quantization bits adopted, under the hypothesis of using uniform midrise quantization, the quantization step is $d_s = T_s/2^{m_s-1}$. The maximum quantization error at the input, for x and y , respectively, is $|\Delta x| = |\Delta y| = d_s/2$, and it reflects on a maximum error $|\Delta z_k|$ on the LLR of the k -th bit. Obviously, this propagated error depends on m_s , and a suitable design criterion should satisfy the condition:

$$|\Delta z_k| \leq \frac{d_e}{2} \tag{24}$$

Where, d_e represents the constant interval amplitude in uniform LLR quantization, while it can be replaced by the minimum interval amplitude (d_e^{\min}) when non-uniform LLR quantization is adopted. If equation (24) is verified, the signal quantization has no impact on the decoder messages quantization, and the BER performance is exactly the same achievable with unquantized input samples. $|\Delta z_k|$ Can be approximated through the following expression:

$$|\Delta z_k| \approx dz_k = \left| \frac{\partial f_k}{\partial x} dx + \frac{\partial f_k}{\partial y} dy \right| \approx \left| \frac{\partial f_k}{\partial x} + \frac{\partial f_k}{\partial y} \right| \frac{d_s}{2} \tag{25}$$

Partial derivatives appearing in (25) can be easily computed, and the final result is:

$$|\Delta z_k| \approx \frac{1}{2} \left| \frac{\sum_{s \in \mathcal{E}_k} (s_x + s_y) e^{-\frac{Xs_x + yS_y}{\sigma^2}} e^{-\frac{|s|^2}{2\sigma^2}}}{\sum_{s \in \mathcal{E}_k} e^{-\frac{Xs_x + yS_y}{\sigma^2}} e^{-\frac{|s|^2}{2\sigma^2}}} \right| \frac{d_s}{2} \tag{26}$$

Where m_s, T_s are implicit in d_s and the noise variance σ^2 influences the results.

B. Optimization of the Signal Quantization Parameters

By computing $\max |\Delta z_k|$ through (26) and inserting it in (5), we are able to find couples of values (m_s, T_s) that, regardless of x and y , ensure an error on the LLRs, as induced by the quantization of the received samples, not larger than that permitted for extrinsic messages quantization. Noting by $2a$ the distance between adjacent symbols in the 16-QAM constellation, the following relationship holds:

$$\frac{1}{\sigma^2} = \frac{SNR}{5a^2} = \frac{4 \cdot k/n \cdot E_b/N_0}{5a^2} \tag{27}$$

Therefore, m_s for fixed T_s , depends on the average signal-to-noise ratio per bit. The required value of m_s for each bit is a step-wise increasing function of E_b/N_0 . Clearly, in order to satisfy condition (24) in a given range of values and for all the bit positions, it is necessary to assume the greatest (i.e., most stringent) value of m_s .

This estimate can be used to forecast the actual performance. For the sake of verification, we have considered uniform quantization of the decoder messages (that is the most critical case, having constant resolution) and repeated, in Fig. 4, the simulation in Fig. 5, but now considering also the quantization of the received samples for different numbers of quantization bits $m_s \in [5,10]$. Coherent with the theory, the curve with $m_s = 10$ is exactly superposed to the unquantized one. Anyway, we also see that the simulated performance degradation for a lower m_s can be very small, and even with $m_s = 5$ it remains below 0.2 dB.

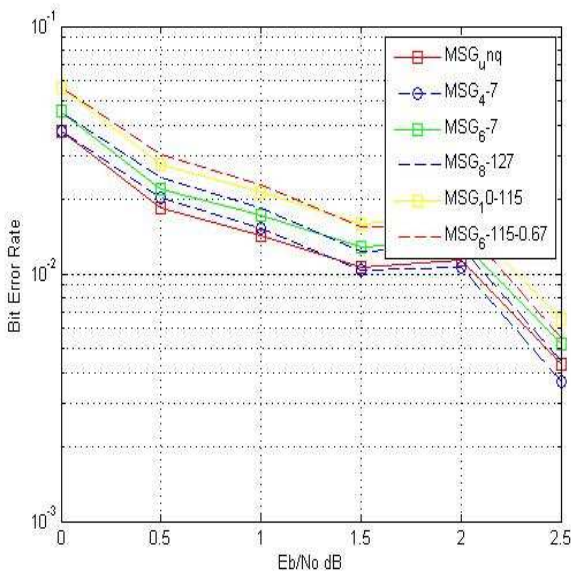

(a)

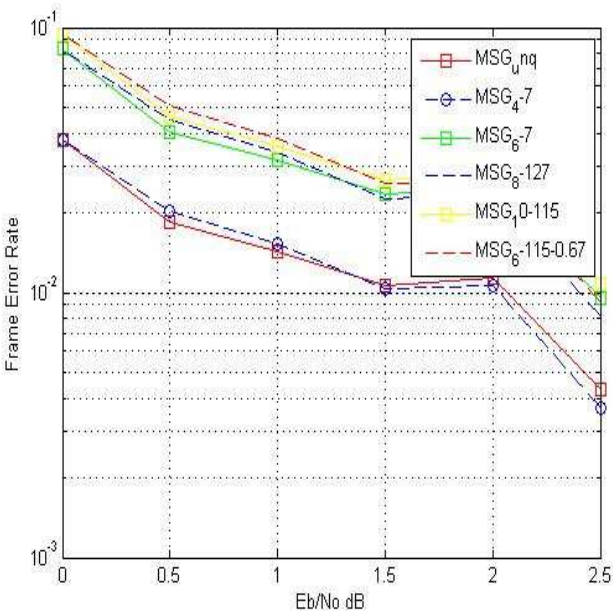

(b)

Fig. 4 Performance of the considered LDPC code for uniform (Msg m_e-T_e) and non uniform (Msg m_e-T_e-F) midtreed decoder messages quantization:(a)BER versus E_b/N_o (b) FER versus E_b/N_o .

The value of m_s obtained by imposing (24) is quite conservative; it aims to ensure that the error on the received samples is always not greater than that on the decoder messages. When such a condition is unsatisfied, it is not realistic to think that performance becomes immediately bad: first of all the threshold at the right hand side of (24) could be exceeded for a small fraction of time and by a limited amount;

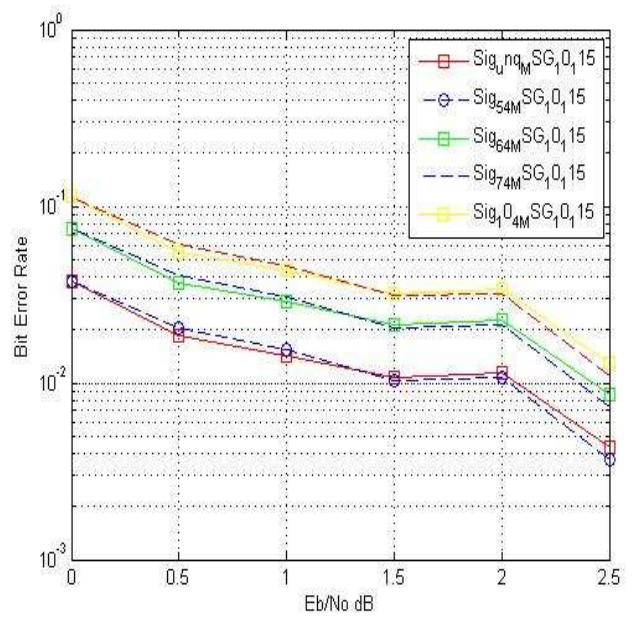

(a)

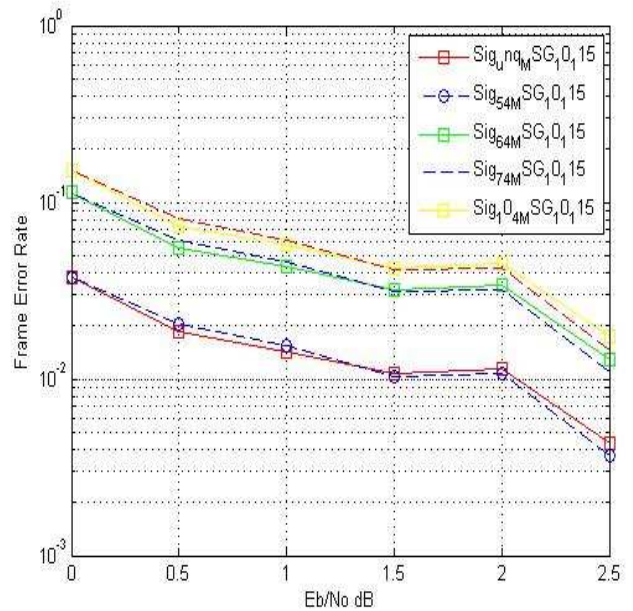

(b)

Fig. 5 Performance of the considered LDPC code for uniform midrise samples quantization (Sig m_e-T_e) and uniform midtreed decoder messages quantization(Msg m_e-T_e):(a)BER versus E_b/N_o (b) FER versus E_b/N_o .

secondly, the sensitivity of the decoding algorithm on the initial condition should be taken into account, so that it is not sure that any excess translates into an additional error. For this reason, the value of m_s calculated by means of (5) only represents a "sufficient" condition to obtain the desired good performance. On the other hand, one can object that such an overestimate (in the specified sense) of the value of m_s obliges

to operate with a number of quantization bits unacceptably high. However, it should be noticed that the value of m_s only affects the demapper, not the decoder (whose registers are involved in the message passing algorithm) [8].

VI. DEMAPPER BASED ON APROXIMATION EXPRESSION

A. Second Order Approximation

The value of SNR (and then of E_b/N_o) is sufficiently high, can be greatly simplified by considering, in each sum. This dominant contribution is due to the signals $s^0 = s^0 + js_y^0 \in A_k$ and $s^1 = s^1 + js_y^1 \in B_k$ for which k , are at minimum distance from the received sample. This technique coincides with the log-sum approximation and has been successfully applied for both product codes [6] and convolutional codes [7]. Actually, by imposing this simplification and taking into account becomes:

$$|\Delta\Delta_k| \approx \frac{SNR}{5a^2} / (s_x^0 - s_x^1) + (s_y^0 - s_y^1) / \frac{d_s}{2}. \quad (28)$$

It is easy to see that s^0 and s^1 have always in common the in-phase component (i.e., $s_x^0 = s_x^1$) or the quadrature component (i.e., $s_y^0 = s_y^1$) and that the maximum difference between the unequal components is $4a$. Together with the highlighted maximum value, with simple algebra we find:

$$m_s \geq \left\lceil \log_2 \left[\frac{SNR \cdot T_S}{5ade} \right] \right\rceil + 3 \quad (29)$$

where $\lceil x \rceil$ is the smallest integer greater than x .

The same simplification used in (28) can be also introduced in the LLR expression. This looks like the classic max-log approximation. Under the same hypotheses:

$$\begin{aligned} L(b_k) &\approx L'(b_k) \\ &= SNR \frac{(x-s_x^1)^2 + (y-s_y^1)^2 - (x-s_x^0)^2 - (y-s_y^0)^2}{10a^2} \\ &= f'_k(x,y)\sigma x \end{aligned} \quad (30)$$

The residual difference between $L(b_k)$ and $L'(b_k)$, is appreciable for small signal-to-noise ratios. An example is shown in Fig. 6, for $E_b/N_o = 0$ dB, where $L(b_1)$ and $L(b_2)$ are plotted as a function of x , for an arbitrary y . The difference becomes smaller and smaller for increasing signal-to-noise ratios and, at the values of E_b/N_o of interest (i.e., those required to have low error rates), it is usually acceptable for all bits. An example is shown in Fig. 7 for $E_b/N_o = 8$ dB; in this case the exact and approximate curves are almost overlaid. In comparison with Fig. 6, it is interesting to observe the very different LLRs dynamics.

B. Simplified Demapper

The acceptability of the approximation suggests a simple solution to reduce considerably the complexity of the demapper block. The exact expression for $L(b_k)$, in fact, requires the implementation of a processor to calculate $f'_k(x, y, \sigma)$, for given inputs. An alternative solution would be to store the values of $f'_k(x, y, \sigma)$ in a Look Up Table (LUT) indexed on x_q, y_q, σ_q (i.e. the quantized versions of x, y, σ , respectively). Due to the linearity in the SNR from the equation (30), the m_c bit level indexes the quantized version of $f'_k(x,y) = (x-s_x^1)^2 + (y-s_y^1)^2 - (x-s_x^0)^2 - (y-s_y^0)^2$ to be stored in the LUT, in place of those of $L'(b_k)$.

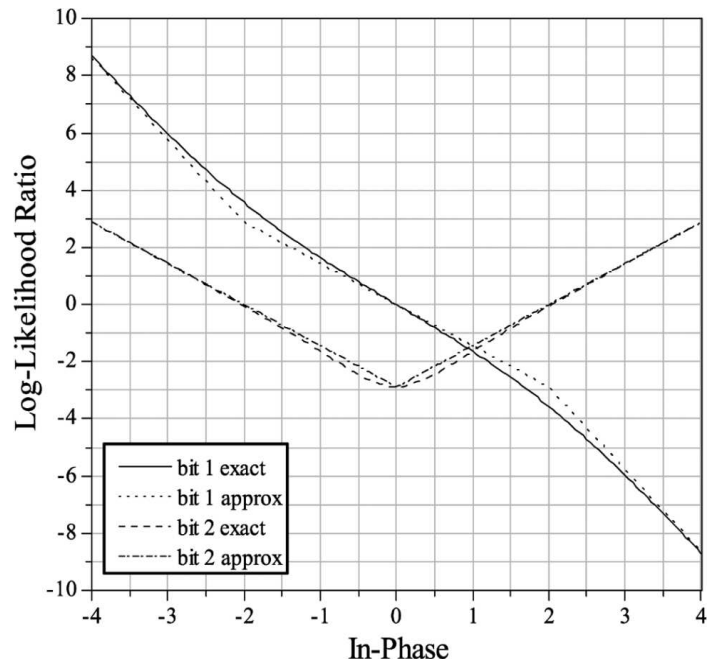

Fig. 6 Comparison between the exact and approximate LLRs for the first two bits, as a function of x (fixed y), at $E_b/N_o = 0$ dB

The dependence on the SNR is eliminated, and the m_c bit output words only depend on the m_s bit input words, regardless of the channel. To reconstruct the value of $L'(b_k)$ from each m_c bit value, if needed, the circuit shown in Fig. 8 can be adopted. It multiplies each level index by the fixed point representation of $SNR/(10a^2)$. This circuit uses an SNR value that is continuously estimated at the receiver side, by using the Signal / Mean Square Error (S/MSE) ratio. When multiplication is performed, it is easy to show that, if l is the number of bits used to represent (the always positive quantity) $SNR/(10a^2)$ and the m_c bit index includes one sign bit, then output value of $L'(b_k)$ can be represented through $m' = m_c + l$ bits, at the most.

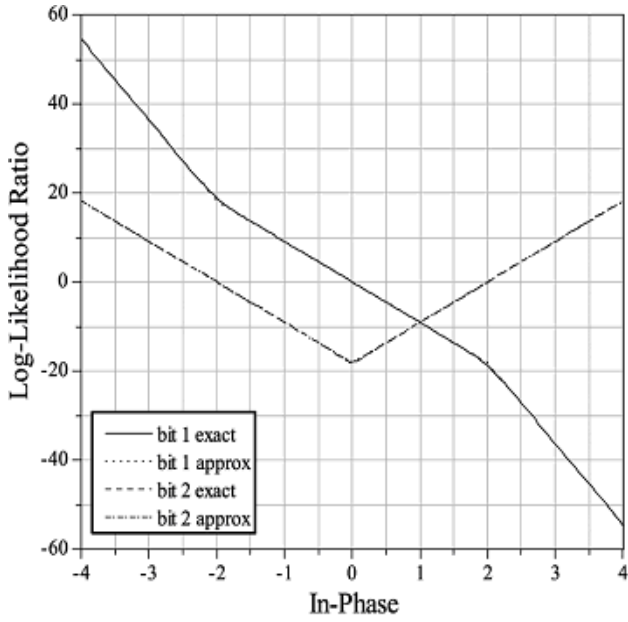

Fig. 7 Comparison between the exact and approximate LLRs for the first two bits, as a function of x (fixed y), at $E_b/N_o = 8\text{dB}$.

VI. CONCLUSION

We studied the performance of LDPC-coded modulation systems with 8PSK and 16QAM. With the proposed Second order approximation demapper strategy, a 0.15 dB - 0.2 dB performance improvement over the conventional mapping method is achieved. The performance of LDPC-coded modulation systems with Gray and natural labeling are studied. For natural labeling, iterative decoding/demodulation is required whereas demodulating is necessary for Gray labeling. We showed that mapper and demapper involved systems are always superior to systems.

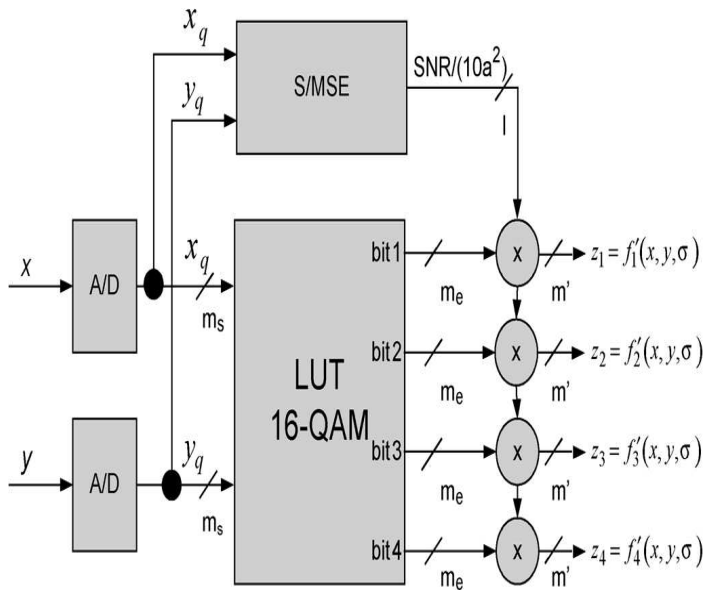

Fig. 8 Circuit for the evaluation of $L'(b_k)$

REFERENCES

- [1] Digital Video Broadcasting (DVB); Second Generation Framing Structure, Channel Coding and Modulation Systems for broadcasting, Interactive Services, News Gathering and Other Broadband Satellite Applications, ETSI EN Std. 302 307 (v1.1.2), Jun. 2006, Rev. 1.1.1.
- [2] J. Hagenauer, E. Offer, and L. Papke, "Iterative decoding of binary block and convolutional codes," *IEEE Trans. Inform. Theory*, vol. 42, no. 2, pp. 429-445, Mar. 1996.
- [3] R. M. Tanner, A recursive approach to low complexity codes, *IEEE Transactions on Information Theory*, vol. 27, IEEE, 1981, pp. 533-547.
- [4] John R. Barry, Low-density parity-check codes, Tech. report, Georgia Institute of Technology, 2001.
- [5] R. Pyndiah, A. Picart, and A. Glavieux, "Performance of block turbo coded 16-QAM and 64-QAM modulations," in *Proc. IEEE Global Telecommunications Conference (GLOBECOM'95)*, Singapore, Nov. 1995, vol. 2, pp. 1039-1043.
- [6] F. Tosato and P. Bisaglia, "Simplified soft-output demapper for binary interleaved COFDM with application to HIPERLAN/2," in *Proc. IEEE ICC 2002*, New York, May 2002, vol. 2, pp. 664-668.
- [7] D. Oh and K. K. Parhi, "Performance of quantized min-sum decoding algorithms for irregular LDPC codes," in *Proc. IEEE ISCAS 2007*, New Orleans, LA, May 2007, pp. 2758-2761.
- [8] S. Papaharalabos, M. Papaleo, P. T. Mathiopoulos, M. Neri, A. Vanelli-Coralli, and G. E. Corazza, "DVB-S2 LDPC decoding using robust check node update approximations," *IEEE Trans. Broadcast.*, vol. 54, no. 1, pp. 120-126, Mar. 2008.