

# Analyzing and Comparing the Hot-spot Thermal Models of HV/LV Prefabricated and Outdoor Oil-Immersed Power Transformers

Ali Mamizadeh, Ires Iskender

**Abstract**—The most important parameter in transformers life expectancy is the hot-spot temperature level which accelerates the rate of aging of the insulation. The aim of this paper is to present thermal models for transformers loaded at prefabricated MV/LV transformer substations and outdoor situations. The hot-spot temperature of transformers is studied using their top-oil temperature rise models. The thermal models proposed for hot-spot and top-oil temperatures of different operating situations are compared. Since the thermal transfer is different for indoor and outdoor transformers considering their operating conditions, their hot-spot thermal models differ from each other. The proposed thermal models are verified by the results obtained from the experiments carried out on a typical 1600 kVA, 30 /0.4 kV, ONAN transformer for both indoor and outdoor situations.

**Keywords**—Hot-spot Temperature, Dynamic Thermal Model, MV/LV Prefabricated, Oil Immersed Transformers

## I. INTRODUCTION

AGING of equipment is predominantly due to a thermal breakdown of its insulating medium [1, 8]. The insulation aging phenomenon has been well documented as a thermal deterioration process in the literature. The most important parameter that should be taken under control is the operating temperature of transformer. For this purpose, deriving and study of the thermal model of a transformer is getting more importance. The thermal model of a transformer is also important when it is aimed to manage the load profile of a power transformer [2, 3, 6] and to program its loading. In power systems the usage of indoor transformer station is preferred due to several reasons such as safety and environmental problems. The variation of the temperature is described by an exponential equation based on the time constant of the transformer top-oil temperature. The temperature of the winding is not uniform and the real limiting factor is actually the hottest section of the winding commonly called winding hot-spot. This hot-spot area is located somewhere toward the top of the transformer, and not accessible for direct measurement with usual methods. The

hot-spot temperature in a transformer winding is the result of summing the ambient temperature, the top-oil temperature rise, and the hot-spot temperature rise over the top-oil temperature. It is assumed that during a transient period, the hot-spot temperature rise with respect the top-oil temperature varies instantaneously with transformer loading, more rapidly than the top oil temperature. In the proposed hot-spot and top-oil thermal models which are based on the thermal-electrical analogy, the ambient temperature and its variation in times have been considered. In the proposed models, the thermal resistance of air ventilation of the cabinet, the thermal resistances and thermal capacitances of different parts of the cabinet (ceiling, walls, door) are considered [2]. The method proposed for calculating thermal capacitance of top-oil temperature rise of oil immersed transformers is in accord with the IEEE Std C57.91-1995 Annex G and is suitable for both aluminum and copper windings [9].

## II. FUNDAMENTAL THEORY OF THERMAL-ELECTRICAL ANALOGY

The analogy between thermal and electric process is briefly given below to analyze the thermal behavior of the inside of the power transformer [2, 6, 9, 10]. A thermal process can be defined by the energy balance given in Eqn. 1.

$$q = C_{th} \frac{d\theta}{dt} + \frac{\theta - \theta_{amb}}{R_{th}} \quad (1)$$

Eqn. 2 is similar to Eqn. 1 corresponding to a simple electric RC circuit.

$$i = C_{el} \frac{dv}{dt} + \frac{v}{R_{el}} \quad (2)$$

The analogy between thermal and electrical process is shown in Fig. 1-a and b, respectively.

A. Mamizadeh is with the Gazi University, Ankara, 06570 Turkey. He is now with the Department of Electrical and Electronic Engineering, Gazi University, Maltepe, Çankaya Ankara 06570 Turkey (phone: +90-312-5823315; fax: +90-312-2308434; e-mail: mamizadeh@gazi.edu.tr).

I. Iskender is with the Gazi University, Ankara, 06570 Turkey. He is now with the Department of Electrical and Electronic Engineering, Gazi University, Maltepe, Çankaya Ankara 06570 Turkey (phone: +90-312-5823315; fax: +90-312-2308434; e-mail: iresis@gazi.edu.tr).

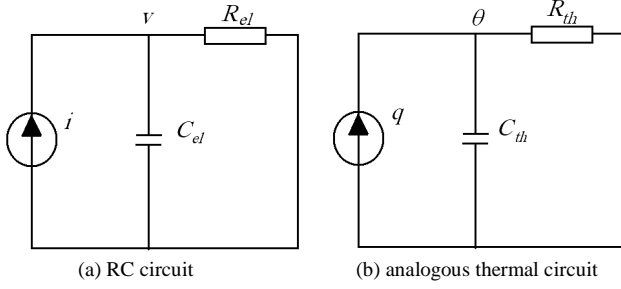

Fig. 1 The electric and thermal–electric circuits (a) electric RC circuit, (b) analogous thermal circuit

### III. THERMAL MODELING

Power losses are converted into heat in a transformer. The losses are composed of no-load losses and load losses. The no-load losses are comprised of eddy-current and hysteresis losses of the core. The load losses are comprised of resistive losses (losses of windings, joint points and connectors), winding eddy current losses and the stray losses.

The heat generated in a transformer transfers (from heat source to oil, from oil to surface and from surface to external environment) by three different heat transfer mechanism as i-convection ii-conduction and iii-radiation. The thermal model is based on the energy balances for the windings, oil, core and tank, cooling equipment and cooling environment.

#### A. Top oil thermal modeling of outdoor situation

The thermal equivalent circuit of an ONAN/OFAF (oil-natural air-natural/oil-forced air-forced) power transformer includes thermal resistance, thermal capacitor and thermal current source. The extended top-oil thermal circuit and model of a power transformer is presented in [2].

For a power transformer,  $q_s$ ,  $q_{fe}$ ,  $q_{pri}$ ,  $q_{sec}$  are the heats generated by the stray losses, the core losses, the primary winding losses and the secondary winding losses, respectively.  $C_m$ ,  $C_{fe}$ ,  $C_{pri}$ ,  $C_{sec}$  are the thermal capacitances of the tank including the other metal components, the core, the primary winding conductor, and the secondary winding conductor, respectively.  $R_{m-o}$ ,  $R_{fe-o}$ ,  $R_{w-o}$ ,  $R_{th-oil-air}$  are the thermal resistances of the tank including the other metal components to oil, core to oil, the windings to oil, and the oil to air, respectively.  $\theta_{oil}$  and  $\theta_{amb}$  are the top-oil and the ambient temperatures, respectively [2, 9].

The load losses can be considered as sum of resistive and stray losses:

$$q_l = q_{pri} + q_{sec} + q_s \quad (3)$$

The thermal resistances  $R_{m-o}$ ,  $R_{fe-o}$ , and  $R_{w-o}$  which are in range of  $5 \times 10^{-5}$  K/W are very low with respect to  $R_{th-oil-air}$  [2, 6]. Therefore, the equivalent thermal model given in [2] can be simplified as Fig. 2.

The thermal capacitance ( $C_{th-oil}$ ) of power transformer top-oil equivalent circuit can be written as [2]:

$$C_{th-oil} = C_m + C_{fe} + C_{pri} + C_{sec} + C_{oil} \quad (4)$$

The top-oil thermal model introduced by IEEE is shown by a first order differential equation as given below [1].

$$\tau_{to} \frac{d\theta_{tor}}{dt} = -\theta_{tor} + \theta_u \quad (5)$$

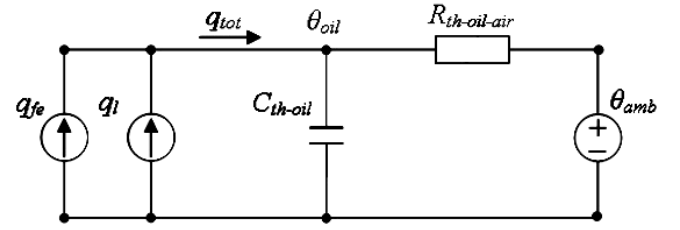

Fig. 2 The simplified equivalent top-oil thermal model

The top-oil temperature rise is obtained from Eqn. 5 as;

$$\theta_{tor} = (\theta_u - \theta_i)(1 - e^{-(t/\tau_{to})}) + \theta_i \quad (6)$$

Eqn. 7 gives the top-oil thermal model suggested by IEEE [1].

$$\left[ \frac{K^2 \beta + 1}{\beta + 1} \right]^n \Delta \theta_{tor} = \tau_{to} \frac{d\Delta \theta_{tor}}{dt} + \Delta \theta_{tor} \quad (7)$$

The top-oil time constant at rated power (kVA) is obtained from Eqn. 8 [1, 11].

$$\tau_{to} = C_{th-oil} R_{th-oil-air} \quad (8)$$

The thermal capacitance of power transformer top-oil is obtained from Eqn. 9 [9].

$$C_{th-oil} = 0.1323 (\text{weight of core in kilograms}) \\ + 0.1323 (\text{weight of copper conductors in kg}) \\ + 0.3162 (\text{weight of aluminum conductors in kg}) \\ + 0.0882 (\text{weight of tank and fittings in kg}) \\ + 0.3513 (\text{liters of oil}) \quad (9)$$

The thermal resistance  $R_{th-oil-air}$  is given by Eqn. 10 [6, 9].

$$R_{th-oil-air} = \frac{\Delta\theta_{tor}}{q_{tot}} \quad (10)$$

The transformer top-oil thermal model given in Fig. 2 is derived from the thermal-analogy and heat transfer theory. The mathematical model corresponding to Fig. 2 is as;

$$q_{fe} + q_l = C_{th-oil} \times \frac{d\theta_{oil}}{dt} + \frac{(\theta_{oil} - \theta_{amb})}{R_{th-oil-air}} \quad (11)$$

### B. Top oil thermal modeling of indoor Situation

Due to limited ventilation in indoor operation the thermal resistance and thermal capacitance of indoor and outdoor transformers are different.

The heat transfer between bodies is as follows:

1. From winding to oil
2. From oil to surrounding air
3. Air inside the room is cooled by natural ventilation and convection heat transfer from the air to room parts (door, walls and ceiling).
4. The heat transfer through the door

The extended model and analogues circuit is presented in [2]. According to presented model, the first cooling component which is dominant is represented by thermal resistance of room to ambient,  $R_{room-amb}$ . The initial form of this thermal resistance is derived from the Hoppner formula [2, 5]. This formula (Eqn. 12) gives the relationship among  $P_l$  (power transferred by natural ventilation),  $R_{hyd}$  (hydraulics resistance of air circulation),  $H$  (cabinet height), and  $\theta_{aex}$  (temperature difference between inlet and outlet holes air).

$$S = \sqrt{\frac{13.2P_l^2 R_{hyd}}{\theta_{aex}^3 H}} \quad (12)$$

From Eqn. 12,  $P_l$  is derived in terms of the other parameters as given in Eqn. 13.

$$P_l = \sqrt{\frac{H}{13.2R_{hyd}}} S \theta_{aex}^{1.5} \quad (13)$$

For the given ventilation hole area, cabinet height, and hydraulics resistance of air circulation the expression under the root sign is constant and the Eqn. 13 can be simplified as Eqn. 14.

$$P_l = c_{con} \theta_{aex}^{1.5} \quad (14)$$

where  $c_{con} = \sqrt{\frac{H}{13.2R_{hyd}}} S$ , using  $\theta_{aex} = R_{vent} \times P_l$  given in [2] the thermal resistance of air ventilation is obtained as Eqn. 15.

$$R_{vent} = 1 / c_{con} \sqrt{\theta_{aex}} \quad (15)$$

Thermal resistance between the cabinet inside air and the cabinet wall and ceiling is as:

$$R_{indoor-w\&c} = 1/\alpha_i S_{w\&c} + d_{w\&c}/\lambda_{w\&c} S_{w\&c} \quad (16)$$

Thermal resistance between the cabinet wall and ceiling with outside ambient is as:

$$R_{w\&c-amb} = 1/\alpha_o S_{w\&c} \quad (17)$$

Thermal resistance between the cabinet inside air and the cabinet door is as:

$$R_{indoor-door} = 1/\alpha_i S_d + d_d/\lambda_d S_d \quad (18)$$

Thermal resistance between the cabinet door with outside ambient is as:

$$R_{door-amb} = 1/\alpha_o S_d \quad (19)$$

The outer heat transfer coefficient can be calculated as Eqn. 20.

$$\alpha_o = 3.958 + 4.304v_o \quad (20)$$

The inner heat transfer coefficient can be calculated as Eqn. 21.

$$\alpha_i = 3.958 + 4.304v_i \quad (21)$$

The velocity inside of prefabricated substation can be calculated as Eqn. 22.

$$v_i = \sqrt{\frac{gH\theta_{aex}}{273 + \theta_{aex} + \theta_{amb}}} \quad (22)$$

The extended model of [2] can be simplified as Fig. 3. Using the given model Eqn. 23 is derived.

$$R_{room-amb} = R_{vent} \parallel (R_{indoor-w\&c} + R_{w\&c-amb}) \parallel (R_{indoor-door} + R_{door-amb}) \quad (23)$$

$C_{indoor}$  is equal to 0.022 times of weight of the prefabricated transformer substation [2].

From solving thermal model given in Fig. 3 the following equations are derived.

$$q_{fe} + q_l = C_{th-oil} \times \frac{d\theta_{oil}}{dt} + \frac{(\theta_{oil} - \theta_{air-room})}{R_{th-oil-room}} \quad (24)$$

$$q_{fe} + q_l + q_{cabin} = C_{indoor} \times \frac{d\theta_{air-room}}{dt} + \frac{(\theta_{air-room} - \theta_{amb})}{R_{room-amb}} \quad (25)$$

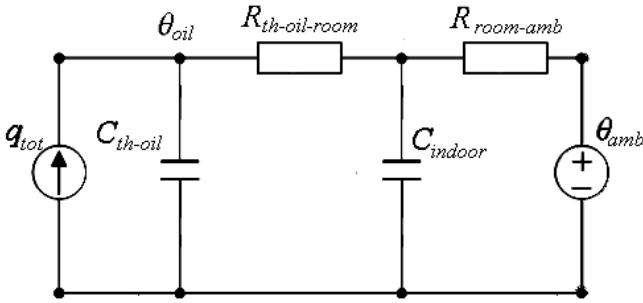

Fig. 3 The equivalent top-oil thermal model for indoor situation

C. Hot-Spot Temperature rise modeling

Similar to the theory given for the top-oil temperature model, the hot-spot temperature model is also represented as a thermal circuit (Fig. 4)

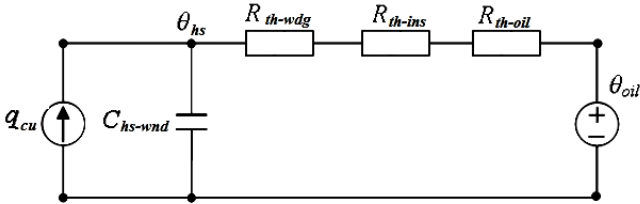

Fig. 4 Hot-spot temperature model

In this model, the heat generated by load losses is represented as an ideal heat source and the top-oil temperature forms an ideal temperature source [6]. The thermal resistance is defined by the heat transfer theory, which has already been applied to the top-oil thermal model as explained below. The winding to oil thermal resistance is given by the following equation:

$$R_{th-hs-oil} = R_{th-wdg} + R_{th-ins} + R_{th-oil} \quad (26)$$

where  $R_{th-wdg}$  is the winding thermal resistance,  $R_{th-ins}$  is the insulation thermal resistance, and  $R_{th-oil}$  is the oil thermal resistance.

Comparing the resistances given in (26) the following correlations can be considered [6].

$$R_{th-oil} \gg R_{th-wdg} \quad (27)$$

$$R_{th-oil} \gg R_{th-ins} \quad (28)$$

Fig. 5 is derived considering the simplified thermal model of hot-spot temperature obtained from Fig. 4 and the above given thermal correlations [6]. Thus, the final equation for the winding to oil thermal resistance is as;

$$R_{th-hs-oil} = R_{th-oil} \quad (29)$$

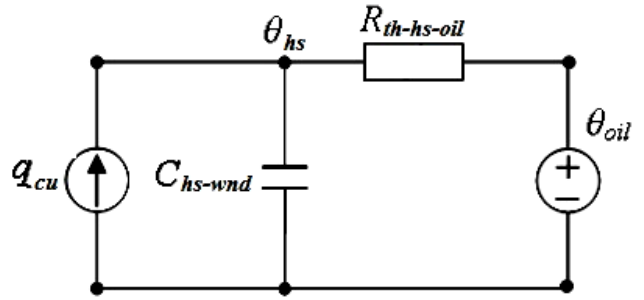

Fig. 5 Simplified Hot-spot temperature model

The result obtained from applying the energy balance theorem to the thermal circuit shown in Fig. 5 is:

$$q_{cu} = C_{th-wdg} \times \frac{d\theta_{hs}}{dt} + \frac{(\theta_{hs} - \theta_{oil})}{R_{th-hs-oil}} \quad (30)$$

Fig.6. shows the hot-spot and top-oil models for two different situations of outdoor and indoor.

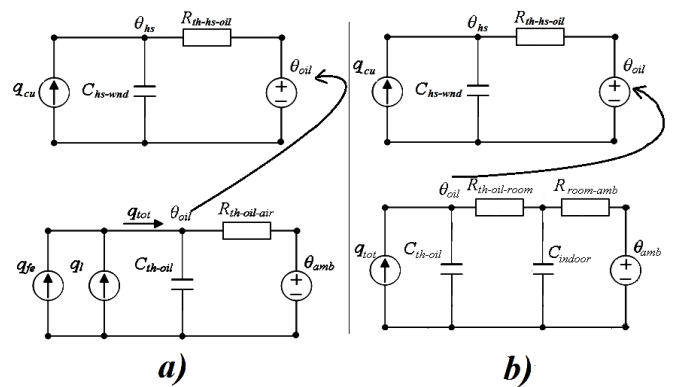

Fig. 6 Hot-spot temperature model a) Outdoor situation b) Indoor situation

IV. EXPERIMENTAL TEMPERATURE RISE TESTS

To verify the models derived for outdoor and indoor transformers the experiments were carried out on a transformer under indoor and outdoor situations. The temperature rise results obtained from experimental tests and theoretical study

for indoor and outdoor transformers are shown in Fig. 7, 8 and 9. In these tests, power injected to the primary windings of the transformer (secondary windings are short circuited) [1, 4, 7] are equal. The figures verify the fact that for the same load and the same conditions, the top-oil and hot-spot temperatures of indoor transformer are higher than those for outdoor transformer.

Fig. 7 shows the experimental results for top-oil and ambient temperatures and the results obtained using the top-oil and hot-spot thermal models for outdoor situation. In this figure, the top oil experimental results are also compared with simulation results of the derived model.

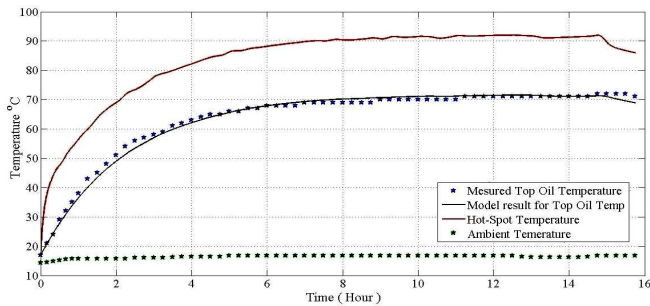

Fig. 7 Comparing experimental and theoretical results of the top-oil and hot-spot temperature rise for outdoor situations

Fig. 8 shows the experimental results for top-oil and ambient temperatures and the results obtained using the top-oil and hot-spot thermal models for indoor situation. In this figure, the top oil experimental results are also compared with simulation results of the derived model.

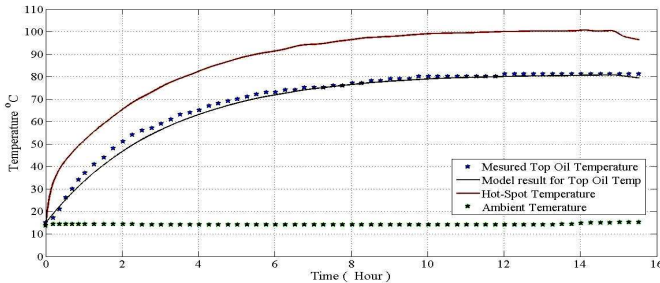

Fig. 8 Comparing experimental and theoretical results of the top-oil and hot-spot temperature rise for indoor situations

The top-oil and hot-spot results for indoor and outdoor situations are compared in Fig. 9.

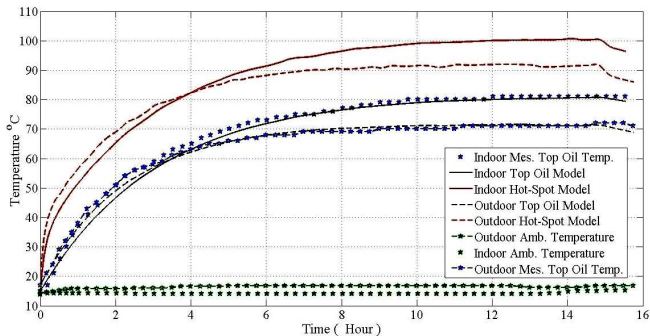

Fig. 9 Comparing results of the top-oil and hot-spot temperature rise for outdoor and indoor situations

The temperature difference between the hot-spot and top-oil temperatures for two different situations of indoor and outdoor are shown and compared in Fig. 10.

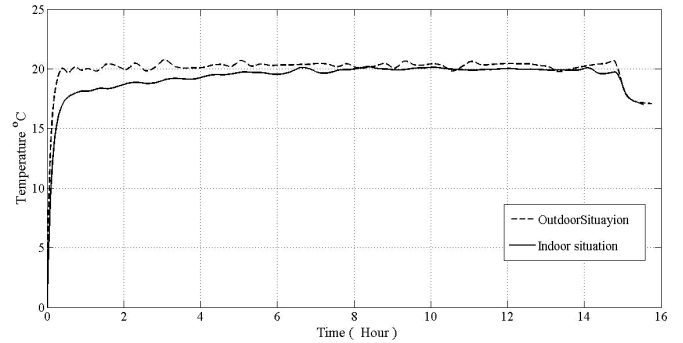

Fig. 10 Comparing hot-spot rise over top oil temperature for outdoor and indoor situations

### V. CONCLUSION

The hot-spot thermal models of oil immersed power transformer are derived for indoor and outdoor situation. In the hot-spot models proposed for both situations, the variation of ambient temperature is also considered. For the indoor situation, the thermal resistance and the thermal capacitances of different parts of the cabinet, the capacitance effect of “ring main unit” (RMU), and also the power losses of all enclosure components used in service are considered.

An important difference between the top-oil and hot-spot temperatures for two different operating cases (indoor and outdoor) is that, for the same input power, the top-oil and hot-spot temperature of indoor transformer is higher than that for outdoor (Fig. 9). The difference between the hot-spot and top-oil temperatures for two different situations are nearly equal for steady state duration but the corresponding temperature difference is lower for indoor situation than that for outdoor operation for load starting duration or transient (Fig. 10).

Another important point is that, in loading management of transformers the hot-spot temperature should be considered as reference instead of the top-oil temperature. This is due to lower thermal time constant of the hot-spot temperature with respect to thermal time constant of the top-oil temperature.

### ACKNOWLEDGMENTS

This study was supported by Scientific and Technological Research Council of Turkey (TUBITAK) under 109E161contract grant number.

### REFERENCES

- [1] Guide for Loading Mineral-Oil-Immersed Transformers, IEEE Standard C57.91, 1995. 12 June 2003.
- [2] I. Iskender, A. Mamizadeh, “An improved nonlinear thermal model for MV/LV prefabricated oil-immersed power transformer substations”*Electrical Engineering Volum :93 Issue: 1 pages :9-22 Mar 2011*
- [3] G. Swift, T. Molinski, W. Lehn, and R. Bray, “A fundamental approach to transformer thermal modeling—Part I: Theory and equivalent circuit,” *IEEE Trans. on Power Delivery*, vol. 16, no. 13, 2001.
- [4] IEC 60076-2 power transformer part 2 temperature rise, IEC standard 60076-2

- [5] Z. Radakovic, S. Maksimovic, " Non-stationary thermal model of indoor transformer stations ", *Electrical Engineering* 84 (2002) 109–117 – Springer-Verlag 2002 , DOI 10.1007/s00202-001-0111-5
- [6] D. Susa, M. Lehtonen, H. Nordman, "Dynamic Thermal Modeling of Power Transformers" , *Ieee Transactions On Power Delivery*, Vol. 20, No. 1, January 2005.
- [7] High-voltage switchgear and controlgear – Part 202: High-voltage/low-voltage prefabricated substation , IEC Standard 62271-202 , 06 2006
- [8] IEEE C57.100-1999, IEEE Standard Test Procedure for Thermal Evaluation of Liquid-Immersed Distribution and Power Transformers.
- [9] I. Iskender, A. Mamizadeh, "Thermal Capacitance Calculation of Top-Oil Temperature for Power Transformers", *International Review of Electrical Engineering (IREE)*, VOL. 4, NO. 5, Part A, Page 882-886, September – October 2009
- [10] V. V. S. S. Haritha, T. R. Rao, A. Jain, M. Ramamoorthy, "Thermal Modeling of Electrical Utility Transformer", *Third International Conference on Power Systems (ICPS 2009)*, Report No: IIT/TR/2009/209, Hyderabad , INDIA, December 2009
- [11] Daniel J. Tylavsky, Xiaolin Mao, Gary A. McCulla, "Transformer Thermal Modeling: Improving Reliability Using Data Quality Control", *IEEE TRANSACTIONS ON POWER DELIVERY*, VOL. 21, NO. 3, Pages 1357-1366 JULY 2006