

# A Novel Logarithmic Current-Controlled Current Amplifier (LCCA)

Karama M. AL-Tamimi and Munir A. Al-Absi

**Abstract**—A new OTA-based logarithmic-control variable gain current amplifier (LCCA) is presented. It consists of two Operational Transconductance Amplifier (OTA) and two PMOS transistors biased in weak inversion region. The circuit operates from 0.6V DC power supply and consumes 0.6  $\mu$ W. The linear-dB controllable output range is 43 dB with maximum error less than 0.5dB. The functionality of the proposed design was confirmed using HSPICE in 0.35 $\mu$ m CMOS process technology.

**Keywords**—LCCA, OTA, Logarithmic, VGA, Weak inversion, Current-mode

## I. INTRODUCTION

LOGARITHMIC amplifier produces an output that is proportional to the logarithm of the input. Such circuits are used in applications that require compression of analog input data, linearization of transducers that have exponential outputs, and analog multiplication and division.

In certain applications, a signal may be too large in magnitude for a particular system to handle. The term dynamic range is often used to describe the range of voltages/currents contained in signal. In these cases, the signal voltage must be scaled down by a process called signal compression so that it can be properly handled by the system. If linear circuit is used to scale down the amplitude of the signal, the lower voltages/currents are reduced by the same percentage as the higher voltages/currents. Linear signal compression often results in the lower voltages /currents becoming obscured by noise and difficult to accurately distinguish. To overcome this problem, signal with large dynamic range can be compressed using logarithmic circuit. In logarithmic signal compression the higher voltages/currents are reduced by a greater percentage than the lower voltages, thus keeping the lower voltage signals from being lost in noise [1]. In addition to that, the circuits that have the gain which is logarithmically controlled will be a very useful and very attractive in many applications.

It is well known, the Variable Gain Amplifier (VGA) circuit is an important building block for an Automatic Gain Control (AGC) applications e.g. in communication and instrumentation systems [2-5]. There are many exponential-

controls VGA circuits [6-9], however the logarithmic-control VGA circuits are very rare to see in recent years [10, 11].

Nowadays, the demand for portable operation of electronic systems has lead to the trend of designing circuits with low voltage and low power consumption. One possible method to realize the low-power consumption circuits is to operate MOSFETs in the weak inversion region [12-17]. In this paper, a new low-power and low-voltage logarithmic-control variable gain current amplifier is developed. In section 2, description and mathematical analysis of the proposed design is presented. Simulation results and discussion are presented in section 3. The paper conclusion is presented in section 4.

## II. PROPOSED LOGARITHMIC-CONTROL VGA CIRCUIT

The block diagram of the proposed design is shown in Fig. 1. It consists of two OTAs, current mirror and two PMOS transistors biased in weak inversion region used for current to-voltage conversion.

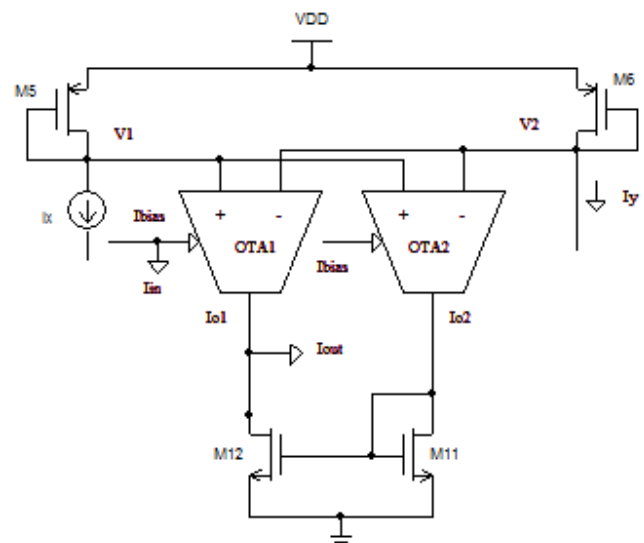

Fig. 1 Block diagram of the proposed design

With reference to Fig. 1, the output current of the OTA is given by:

$$I_{out} = g_m (V_1 - V_2) \quad (1)$$

Where  $g_m = \frac{I_D}{nU_T}$ , the transconductance of MOS in weak

inversion region used in the OTAs,  $V_1$  and  $V_2$  are the two input voltages. The controlled currents  $I_x$  and  $I_y$  are converted to voltages  $V_1$  and  $V_2$  in logarithmic form through

Karama Mohammed AL-Tamimi is M.Sc. student with the Electrical Engineering Department at King Fahd University of Petroleum & Minerals (KFUPM), Dhahran 31261, KFUPM Box 7891 KSA (Cell phone: +966-535752181; e-mail: kmt340@gmail.com).

Munir A. AL-Absi is an Associate Professor with the Electrical Engineering Department, KFUPM University, Dhahran, KSA (Phone: +966-3-860-3696; fax: +966-3-860-3535 ;e-mail: mkulaib@kfupm.edu.sa).

transistors  $M_5$  and  $M_6$  respectively according to the following equations:

$$V_1 = V_{DD} - V_{sg5} = V_{DD} - nU_T \ln\left(\frac{I_x}{I_{D0}}\right) \quad (2)$$

$$V_2 = V_{DD} - V_{sg6} = V_{DD} - nU_T \ln\left(\frac{I_y}{I_{D0}}\right) \quad (3)$$

Where  $V_{DD}$  is the supply voltage and  $V_{sg}$  is the source to gate voltage,  $U_T = \frac{KT}{q}$  is the thermal voltage,  $n$  is the slope factor and  $I_{D0}$  is the leakage current of the MOSFET.

Combining equations (1), (2) and (3), it is easy to show that the output currents of OTA1 and OTA2 are given by (4) and (5) expressed:

$$I_{O1} = \left(I_{in} + \frac{I_{bias}}{2}\right) \cdot \ln\left(\frac{I_y}{I_x}\right) \quad (4)$$

$$I_{O1} = \frac{I_{bias}}{2} \cdot \ln\left(\frac{I_y}{I_x}\right) \quad (5)$$

$$A_i = \frac{I_{out}}{I_{in}} = \ln\left(\frac{I_y}{I_x}\right) \quad (7)$$

According to equation (7) a variable-gain current amplifier can be realized and its gain can be logarithmically controlled by the currents  $I_x$  and  $I_y$ .

The complete circuit diagram of the proposed design is shown in Fig. 2. Transistors M1-M4 and M7-M10 form OTA<sub>1</sub> and OTA<sub>2</sub> respectively. Transistors M11& M12 form the current mirror required to mirror  $I_{O2}$  into transistor M12.

### III. SIMULATION RESULTS AND DISCUSSION

The proposed design was simulated using HSPICE level 49 in 0.35µm 2p4m CMOS process technology. The results obtained at  $I_{bias} = 100\text{ nA}$ ,  $I_x = 100\text{ nA}$ ,  $I_{in} = 100\text{ nA}$  and  $V_{DD} = -V_{SS} = 0.6\text{V}$ . The output current was measured by forcing it through a grounded load resistor  $R_L = 10\text{ k}\Omega$ . The control current  $I_y$  was varied from 10 nA to 500 nA and the measured gain range is around 43 dB. The simulation result is shown in Fig 3.

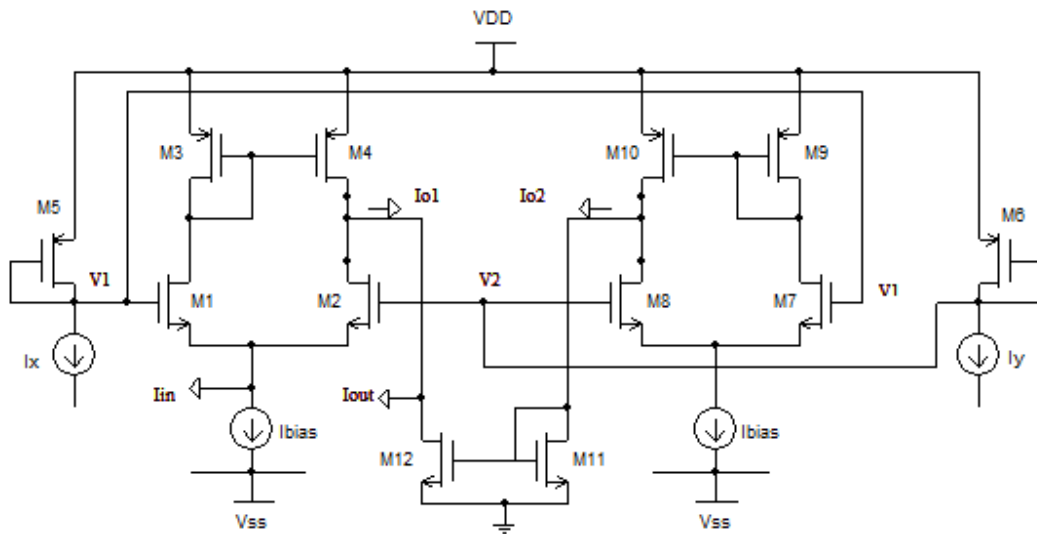

Fig. 2 Complete circuit diagram of proposed design

With reference to Fig. 1 and from (4) and (5) the output current is given by:

$$\begin{aligned} I_{out} &= I_{O1} - I_{12} \\ I_{out} &= I_{O1} - I_{O2} \\ I_{out} &= I_{in} \cdot \ln\left(\frac{I_y}{I_x}\right) \end{aligned} \quad (6)$$

The amplifier gain is given by:

It appears from Fig. 3 that the simulated results are in a good agreement with the theoretical one, which confirms the functionality of the developed design.

Fig. 4 shows the error between the simulated results and the theoretical values. The maximum simulated error is 1.65dB%

which occurred at normalized current  $\frac{I_y}{I_x} = 0.98$  and

$I_{in} = 100\text{ nA}$ , however most of the simulated errors are less than 0.5dB%. The simulated maximum power consumption

for the proposed design is around 0.6  $\mu$ W.

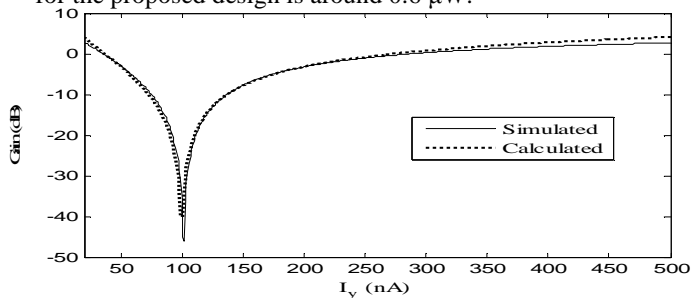

Fig. 3 Simulation results of the proposed VGA ( $I_x = 100$  nA ,  $I_m = 100$  nA )

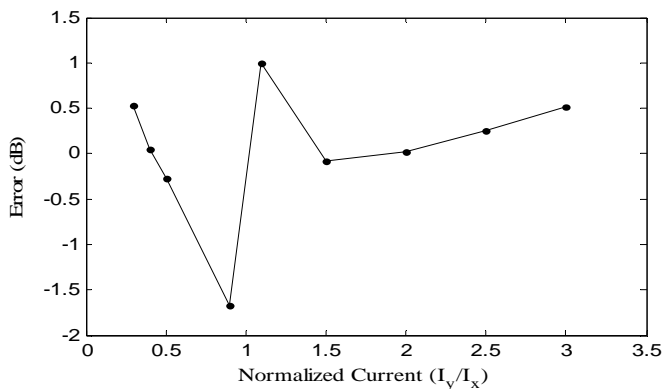

Fig. 4 Errors between the simulated and the theoretical results (@  $I_m = 100$  nA )

#### IV. CONCLUSION

In this paper, a new OTA-based logarithmic-control VGCA is developed. The design enjoys simplicity and attractive for integration. This block can be a very useful block in analog signal processing circuits and systems. The design operates from low voltage supply and consumes very small amount of power.

#### ACKNOWLEDGMENT

Acknowledgment is due to King Fahd University of Petroleum and Minerals for providing support to this work.

#### REFERENCES

[1] Thomas L. Floyd, Electronic Devices (Conventional Flow Version), 6th ed. (Prentice Hall, 2001).  
 [2] V.T.S. Vintola et al., "Variable-gain power amplifier for mobile WCDMA applications," IEEE Transactions on Microwave Theory and Techniques 49 (December 2001): 2464-2471.  
 [3] D. Coffing et al., "A variable gain amplifier with 50-dB control range for 900-MHz applications," IEEE Journal of Solid-State Circuits 2 (September 2002): 1169-1175.  
 [4] B. Sewiolo, G. Fischer, and R. Weigel, "A 30 GHz Variable Gain Amplifier With High Output Voltage Swing for Ultra-Wideband Radar," IEEE Microwave and Wireless Components Letters 19 (September 2009): 590-592.  
 [5] K. Hadidi and H. Kobayashi, "A 25 MHz 20 dB variable gain amplifier" (Instrumentation and Measurement Technology Conference, 1994.

IMTC/94. Conference Proceedings. 10th Anniversary. Advanced Technologies in I & M., 1994 IEEE), vol.2, pp. 780-783, May 1994  
 [6] Liu W and Liu S-I, "Low Voltage and Low Power CMOS Exponential-Control Variable-Gain Amplifier," IEICE Trans Fundam Electron Commun Comput Sci (Inst Electron Inf Commun Eng) E87-A, no. 4 (2004): 952-954.  
 [7] C. -C Chang, M. -L Lin, and S. -I Liu, "CMOS current-mode exponential-control variable-gain amplifier," Electronics Letters 37, no. 14 (July 5, 2001): 868-869.  
 [8] W. Liu, S. -I Liu, and S. -K Wei, "CMOS exponential-control variable gain amplifiers," Circuits, Devices and Systems, IEE Proceedings - 151, no. 2 (April 12, 2004): 83- 86.  
 [9] Po-Chiun Huang, Li-Yu Chiou, and Chong-Kuang Wang, "A 3.3-V CMOS wideband exponential control variable-gain-amplifier," in Proceedings of the 1998 IEEE International Symposium on Circuits and Systems, 1998. ISCAS '98, vol. 1 (presented at the Proceedings of the 1998 IEEE International Symposium on Circuits and Systems, 1998. ISCAS '98, IEEE, 1998), 285-288 vol.1.  
 [10] John M. Tammone, Jr., "United States Patent: 6229374 - Variable gain amplifiers and methods having a logarithmic gain control function", May 8, 2001.  
 [11] M. Mizutani, "Patent 4628276" - Logarithmically linearly controlled variable gain amplifier (Google Patents, December 14, 1984).  
 [12] W. Liu and S. I Liu, "Low-voltage and low-power CMOS voltage-to-current converter," IEICE transactions on electronics 87, no. 6 (2004): 1029-1032.  
 [13] Weihsing Liu, Wei-Lung Mao, and Jyh Sheen, "A Low-power and Low-voltage Cube-law Circuit Design using MOSFETs," in Electron Devices and Solid-State Circuits, 2007. EDSSC 2007. IEEE Conference on, 2007, 829-832.  
 [14] A. Nag and R.P. Paily, "Low power squaring and square root circuits using subthreshold MOS transistors," in Emerging Trends in Electronic and Photonic Devices & Systems, 2009. ELECTRO '09. International Conference on, 2009, 96-99.  
 [15] M.A. Al-Absi, "Low-voltage and low-power CMOS current-mode divider and 1/x circuit," in Electronic Devices, Systems and Applications (ICEDSA), 2010 Intl Conf on, 2010, 245-247.  
 [16] F. Serra-Graells and J.L. Huertas, "Low-voltage CMOS subthreshold log amplification and AGC," Circuits, Devices and Systems, IEE Proceedings - 152, no. 1 (2005): 61-70.  
 [17] C.-H. Kao, W.-P. Lin, and C.-S. Hsieh, "Low-voltage low-power current mode exponential circuit," Circuits, Devices and Systems, IEE Proceedings - (2005): 633-635.  
 [18] J. Pimentel, F. Salazar, M. Pacheco, and Y. Gavriel, "Very-low-power analog cells in CMOS," 2000 Proc. 43rd IEEE Midwest Symposium on Circuits and Systems, vol.1, pp.328 -331, 2000.

**Karama M. AL-Tamimi** was born in Hadhramout, Yemen in 1982. He received the B.Sc. degree in electronic & communication engineering from Hadhramout University of Science & Technology (HUST), Hadhramout, Yemen in July 2007. He was a graduate assistant at Electronic & Communication Department in HUST from September 2007 to January 2009. He is currently M.Sc. Student with the electronic group at King Fahd University of Petroleum & Minerals (KFUPM), Saudi Arabia. His research interests include Current-Mode CMOS analog Computational Circuits, Circuits using MOSFET in weak inversion region and Analog Circuit Design.

**Dr. Munir A. Al-Absi**, obtained his B.Sc and M.Sc from KFUPM, Dhahran Saudi Arabia in 1984 and 1987 respectively. Obtained his Ph. D form UMIST, UK in 2001. Currently he is an Associate Professor at KFUPM EE department teaching electronics and instrumentation courses. His research interests include analog computational circuits using MOS in weak inversion, and nano-amperes current mirrors.