

The Data Processing Electronics of the METIS Coronagraph aboard the ESA Solar Orbiter Mission

M. Focardi¹, M. Pancrazzi¹, M. Uslenghi², G. Nicolini³, E. Magli⁴, F. Landini¹, M. Romoli¹, A. Bemporad³, E. Antonucci³, S. Fineschi³, G. Naletto⁵, P. Nicolosi⁵, D. Spadaro⁶, V. Andretta⁷.

Abstract—METIS is the Multi Element Telescope for Imaging and Spectroscopy, a Coronagraph aboard the European Space Agency's Solar Orbiter Mission aimed at the observation of the solar corona via both VIS and UV/EUV narrow-band imaging and spectroscopy. METIS, with its multi-wavelength capabilities, will study in detail the physical processes responsible for the corona heating and the origin and properties of the slow and fast solar wind. METIS electronics will collect and process scientific data thanks to its detectors proximity electronics, the digital front-end subsystem electronics and the MPPU, the Main Power and Processing Unit, hosting a space-qualified processor, memories and some rad-hard FPGAs acting as digital controllers. This paper reports on the overall METIS electronics architecture and data processing capabilities conceived to address all the scientific issues as a trade-off solution between requirements and allocated resources, just before the Preliminary Design Review as an ESA milestone in April 2012.

Keywords—Solar Coronagraph, Data Processing Electronics, VIS and UV/EUV Detectors, LEON Processor, Rad-hard FPGAs

I. INTRODUCTION

THE Earth and the other planets of the Solar System orbit inside the extended atmosphere of our Star, a region of interplanetary space known as the heliosphere. Over the past twenty years, a big effort has been undertaken in order to understand the Sun and its influence on its atmosphere with many space missions performing both remote observations at visible, UV/EUV, and X-ray wavelengths, as well as in-situ observations of plasmas, particles, and fields. Combined and coordinated observations from missions such as Ulysses, Yohkoh, SOHO [1], TRACE, RHESSI, Hinode [2] and STEREO [3] as well as those for the recently launched Solar Dynamics Observatory, have formed the strategy for our understanding of the solar corona, the solar wind and the coupling between the Sun and the three-dimensional heliosphere.

Mauro Focardi and Authors¹ are with the Dep. of Physics and Astronomy, University of Florence, Largo E. Fermi 2 - 50125 Firenze - Italy (First Author phone: +39-055-205-5213; fax: 39-055-205-5252; e-mail: mauro@arcetri.astro.it).

Author² is with INAF - Institute of Space Astrophysics and Cosmic Physics, Via Bassini 15 - 20133 Milano - Italy.

Authors³ are with INAF - Turin Astronomical Observatory, Via Osservatorio 20 - 10025 Pino Torinese, Torino - Italy.

Author⁴ is with the Dep. of Electronics, Politecnico of Torino, Corso Duca degli Abruzzi 24 - 10129 Torino - Italy.

Authors⁵ are with the Dep. of Information Engineering, University of Padova, Via Gradenigo 6/B - 35131 Padova - Italy.

Author⁶ is with INAF - Catania Astronomical Observatory, Via S. Sofia 78 - 95123 Catania - Italy.

Author⁷ is with INAF - Napoli Capodimonte Astronomical Observatory, Salita Moiarriello 16 - 80131 Napoli - Italy.

However, an important element of this observational strategy has not been yet implemented. In fact none of these missions have been able to fully explore the interface region where the solar wind take origin and heliospheric structures are formed by means of instrumentation able to fully characterize and link all the detected structures back to their source regions.

In this framework and with the consciousness that much of the crucial physics in the formation and activity of the heliosphere takes place very close to the Sun, became clear that flying a spacecraft with a combined remote-sensing and in-situ payload instruments into the inner solar system will critically advance our knowledge on *how does the Sun create and control the heliosphere*. This is in fact one of the major scientific questions that will be addressed by the ESA Cosmic Vision 2020-2025 program thanks to the implementation of the Solar Orbiter (SO) Mission [4]. SO will benefit of unprecedented observational capabilities, provided by the powerful combination of in-situ and remote-sensing instruments and the unique inner-heliospheric mission phase that will bring the spacecraft to within 0.28 AU and that was specifically designed to address the previous question.

The proximity to the Sun, coupled with the capability of providing imaging and spectral observations of the Sun's polar region from out of the ecliptic, will also have the advantage that the spacecraft will benefit of reduced angular velocity periods with respect to the solar surface. This particular orbit will allow the observations of low atmospheric features and their connections to the heliosphere for significantly longer periods than from the near-Earth observation point of view.

Solar Orbiter payload will host ten scientific instruments. METIS, the Multi Element Telescope for Imaging and Spectroscopy [5] and [6] is the mission's Coronagraph, a powerful and innovative instrument aimed at the fully characterization of the solar Corona in polarized visible light and UV/EUV light.

II. METIS CORONAGRAPH DESIGN

METIS is conceived to perform off-limb, near-Sun (from 1.5 to 3 solar radii), coronal observations in order to address some still open issues in solar physics, concerning the origin and heating/acceleration of the solar wind streams, the origin, acceleration and transport of the solar energetic particles and the transient ejection of coronal mass and its evolution in the inner heliosphere (CMEs, i.e. coronal mass ejections).

The telescope, in Gregorian configuration, has been designed following a highly innovative approach, which takes

advantage of the multi-wavelength capabilities of multilayers coated mirrors highly reflective both in the visible-light band and in the EUV/UV band. The coronagraph is based on a novel externally occulted design [7] and [8], in which light enters through a circular aperture (the inverted external occulter) located at the outside panel of the spacecraft (S/C) heat shield. The inverted external occulter is supported by a suitable mount, which protrudes from the S/C front panel throughout the heat shield. The instrument is able to select three different coronal light wavelengths by a filter insertion mechanism: either visible, collected by a visible light detector after being processed by a polarizer, and ultraviolet (HI 121.6 nm) or extreme ultraviolet (HeII 30.4 nm) lines collected by a UV/EUV detector.

Thanks to its innovative characteristics, METIS will obtain for the first time near-Sun simultaneous imaging of the full corona in polarized visible-light (500-650 nm) and narrow-band ultraviolet HI Ly α , monochromatic imaging of the full corona in the extreme ultraviolet HeII Ly α and spectroscopic observations in the same spectral line.

In order to implement an UV and EUV spectroscopic channel and keep the instrument within the strict mass and dimension budget imposed by ESA, a 32 degrees circular sector of coronal imaging is sacrificed to allow the insertion of a multi-slit aperture and a dispersion grating. The coronal spectrum is then imaged on a sector of the UV/EUV detector by the same optics of the imaging channel.

This additional spectroscopic channel does not need any mechanism, and shares one of the coronagraph imaging detectors. The only additional resources needed respect to the simple coronagraph configuration is the support for the grating and for the entrance slits, plus a small and light baffling system.

The overall measurements performed by METIS will allow a complete characterization of the three most important plasma components of the corona and the solar wind (electrons, protons and helium ions).

The instrument consists of an Optical Unit (MOU) plus an external electronics box, the Main Power and Processing Unit (MPPU) [9], as shown in Fig. 1, located near the MOU and connected to it by suitable harnesses. The optical unit consists of the visible-light and UV/EUV coronagraph, formed by optics, detectors, thermal hardware, proximity electronics, mechanisms subsystems and electrical interfaces for power supply and telecommand/telemetry links.

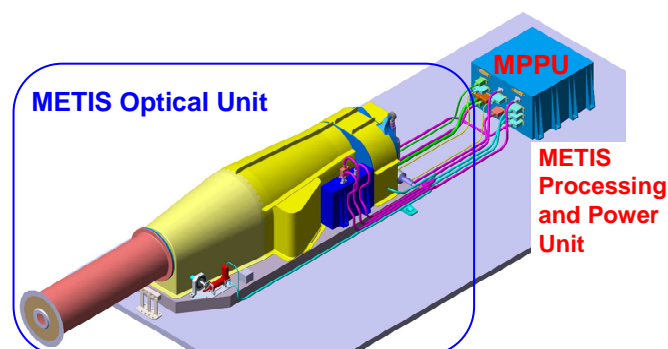

Fig. 1 METIS Coronagraph (courtesy of Thales Alenia Space Italia)

III. METIS ELECTRONICS

A. VIS and UV/EUV detectors assemblies

METIS is essentially an instrument with two scientific channels (Fig. 2) sharing a large part of the telescope optical path, whose multilayers coated mirrors enables the simultaneous operation of both detectors, in UV (HI Ly α) and visible light, whereas when the EUV (HeII Ly α) channel is selected, only the UV/EUV detector is used. In particular, the EUV-light channel relies on an Al (Aluminum) filter that cuts-off all the longer wavelengths.

The METIS visible detector is a 2048x2048 (18 μ m pixel size) CMOS Active Pixel Sensor (APS) by Teledyne [10], the HyViSi model coupled with the H2RG (HAWAII 2RG) Read Out Integrated Circuit (ROIC) multiplexer, managed directly by the Teledyne SIDECAR [11], an ASIC integrating a microcontroller with program and data memory and 4 output 16-bits resolution ADCs, running at sample rates up-to 500 kHz. The SIDECAR design hosts all the capabilities required to operate the APS, including bias and clocks generation. The customized communication serial interface is fully digital, thereby simplifying the design of the instrument while guaranteeing constant low noise performances. The SIDECAR ASIC is connected with a small board (the SIDECAR IF board) providing a SpaceWire (SpW) link to the MPPU for data transfer, telemetry and telecommand purposes. It acts like a command interpreter re-routing and formatting suitable MPPU commands to the SIDECAR microcontroller. The visible detector assembly also receives from the MPPU the basic voltage lines to feed the ASIC and the detector and to supply the thermoelectric cooler coupled with the visible sensor as shown in Fig. 3. The detector is also equipped with a heater in order to avoid ice formation during the initial launch phase due to residual water vapour outgassing from the instrument's subsystems and to preserve VIS-channel cleanliness. The SpW IF is needed to simplify the overall interface harnessing between MOU and MPPU, since the available routing space on the SO optical bench hosting METIS is limited by the presence of some spacecraft subsystems (not shown in Fig. 1).

On the VIS detector optical path is located a Liquid Crystal Variable Retarder (LCVR) polarimeter in order to collect fully linearly polarized images and determine the Stokes parameters useful to investigate for the K-corona electron densities.

On the UV/EUV channel an Intensified Active Pixel Sensor (IAPS) is foreseen in 1Kx1K format, 15 μ m pixel size, given the low expected count rates especially in the HeII Ly α line and the related need to observe in photon counting regime. Observing in the EUV requires a windowless EUV/UV detector, while radiation hardness capability and read-out flexibility like binning and windowing are guaranteed by a CMOS active pixel sensor (Cypress STAR1000), like for the visible channel detector one.

The IAPS is based on a microchannel plate (MCP) intensifier [12] with a phosphor screen output, optically coupled via a 2:1 demagnifying fiber optic taper to the CMOS sensor. A photocathode deposited on the entrance MCP face converts the incoming photons in primary photoelectrons,

which are then multiplied by the MCP and finally converted into optical photons by means of the phosphor screen. At the phosphor output the APS detects these optical photons and converts them into electrons. The voltage level resulting from the current to voltage amplification and conversion is digitized with a 14-bits resolution ADC at a frame rate up-to 12 MHz. The UV/EUV detector can operate in three different modes:

- Analog mode
- Photon counting mode/(SW) accumulation mode
- Test mode

The analog mode is compliant with the case of high photons fluxes but it isn't the main operational mode, being the photon counting one. In this regime the MCP is powered with a voltage lower than 2kV (as baseline), which allows for a linear behaviour of the system between the high-energy photons impinging on the photocathode and the optical photons generated by the phosphor screen. The resulting 1024x1024 pixels matrix is read-out at 14-bit resolution before downloading it to the MPPU. So, in the analog mode, the IAPS acts as a standard imager, collecting coronal images. As the MCP voltage increases over the 2kV threshold, saturation effects dominate and the output electronic clouds have similar overall charge values. In this non-linear regime the system is characterized by a quasi-gaussian pulse height distribution that enables for the discrimination of the single photon signal from the exponentially decaying background distribution.

So the photon counting mode is mainly used when the rate of the impinging photons is low, provided that the APS is operated continuously at a frame rate high enough to avoid overlapping of the charge spots generated by each primary photon. In this case, during the UV detector matrix readout process, a 3x3 pixels window sweeps dynamically the overall frame at up-to 12 MHz rate; photon events are identified and the event centroid (x,y) coordinates are computed at half-pixel resolution by the HDL pre-processing core running in the Detector Control Board (DCB) FPGA and sent to the MPPU as a formatted data stream by the UV-channel SpW link.

When the count rate is higher than a parameterized threshold, the photon counting mode is managed in a different way by the MPPU Application SW (ASW) working in accumulation mode, a SW mode producing a stacked 2048x2048 matrix (with 10 bits depth -as baseline- and half-pixel improved resolution) along with the integrated amplitude profile.

Finally, the test mode is entered when the instrument is driven by the Setup and Configuration operational mode, in order to perform diagnostic procedures. Within this SW mode, for a given event, the pre-processing core hosted inside the processing rad-hard DCB FPGA sends to the MPPU the energy information associated to each pixel of the 3x3 px sub-matrix and its central pixel (x,y) coordinates.

At APS processing level is also foreseen the possibility to implement windowing, which allow for the readout of a subsection of the array. The acquisition by windowing could be useful during spectroscopy measurements or in case of

detection of transient structures like CMEs close to the solar limb. When performing just spectroscopy, the MPPU has not to manage the windowing parameters since this feature can be parameterized and foreseen by the suitable observing program. On the other hand, the windowing for the detection of transient phenomena could be managed directly by the MPPU by two different approaches, i.e. external triggers coming from other SO instruments reporting for the event position or a dedicated algorithm running at CPU level, which evaluates the spatial and temporal variation of the events rate in between subsequent frames.

The intensifier subsystem is maintained in vacuum by means of an ion pump in order to preserve the operating pressure level during ground operations and is equipped with a heater and a temperature sensor to thermally stabilize the detector assembly. A Service Unit is foreseen in order to control the vacuum-tight door opening mechanism, the ion pump and the MCP high voltage power supply (HVPS) during flight and ground-based operations.

As for the VIS channel, the UV/EUV detector digital processing electronics is interfaced to the MPPU thanks to a SpW link and the voltage lines needed to feed the whole assembly. The latter are opportunely filtered and regulated aboard the DCB. The logic circuits implements also a bright protection function monitoring the incoming photon flux on the photocathode. The protection acts regulating the high voltage power line feeding the MCP, with the possibility to switch-off the voltage line in case of spacecraft off-pointing as the internal Sun Sensor flags the direct Sun disk light entering the instrument.

In particular this logic monitors the MCP current threshold, switching-off the HVPS in case of over-current for a period longer than a few milliseconds.

The APS detector subsystem, up-to its digital IF, is provided by the Max Plank Institute of Lindau (Germany), whereas the FPGA photon counting electronics is developed by the Istituto di Astrofisica Spaziale e Fisica cosmica (IASF) of Milano (Italy) and engineered by Thales Alenia Space Italia. The UV door, the MCP assembly and the ion pump with the Service Unit will be provided by the South West Research Institute (SWRI) located in S. Antonio, Texas – USA.

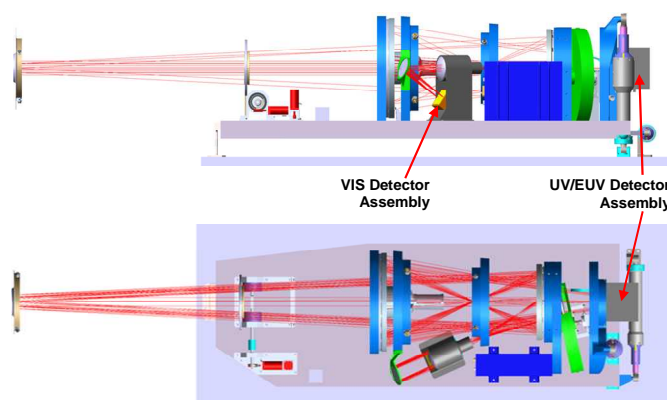

Fig. 2 METIS subsystems configuration, showing the position of the detectors assemblies (courtesy of Thales Alenia Space Italia)

B. Main Power and Processing Unit

The MPPU (Fig. 3) is the main electronics unit of the METIS instrument, hosting the CPU core running the ASW in charge of managing the instrument’s Operative Modes (Fig. 4). The unit is internally divided in several sections implementing different functions. Each section is allocated to a specific electronics board in order to rationalize the overall architecture, developed to address all the scientific issues as a trade-off solution between requirements and allocated resources (mass, power, volume).

card lock retainers. All the connectors are located on the front and on the rear box panels, depending on the IF connection they have to provide, to the S/C On Board Computer (OBC) or to the METIS subsystems.

The motherboard is placed perpendicular to the other 6 boards. The internal connection between each board and the motherboard is implemented by means of suitable FRB connectors. Motherboards hosts also the connectors to the spacecraft, while all the connectors to the subsystems are directly mounted on the functional PCB boards. The PCBs are

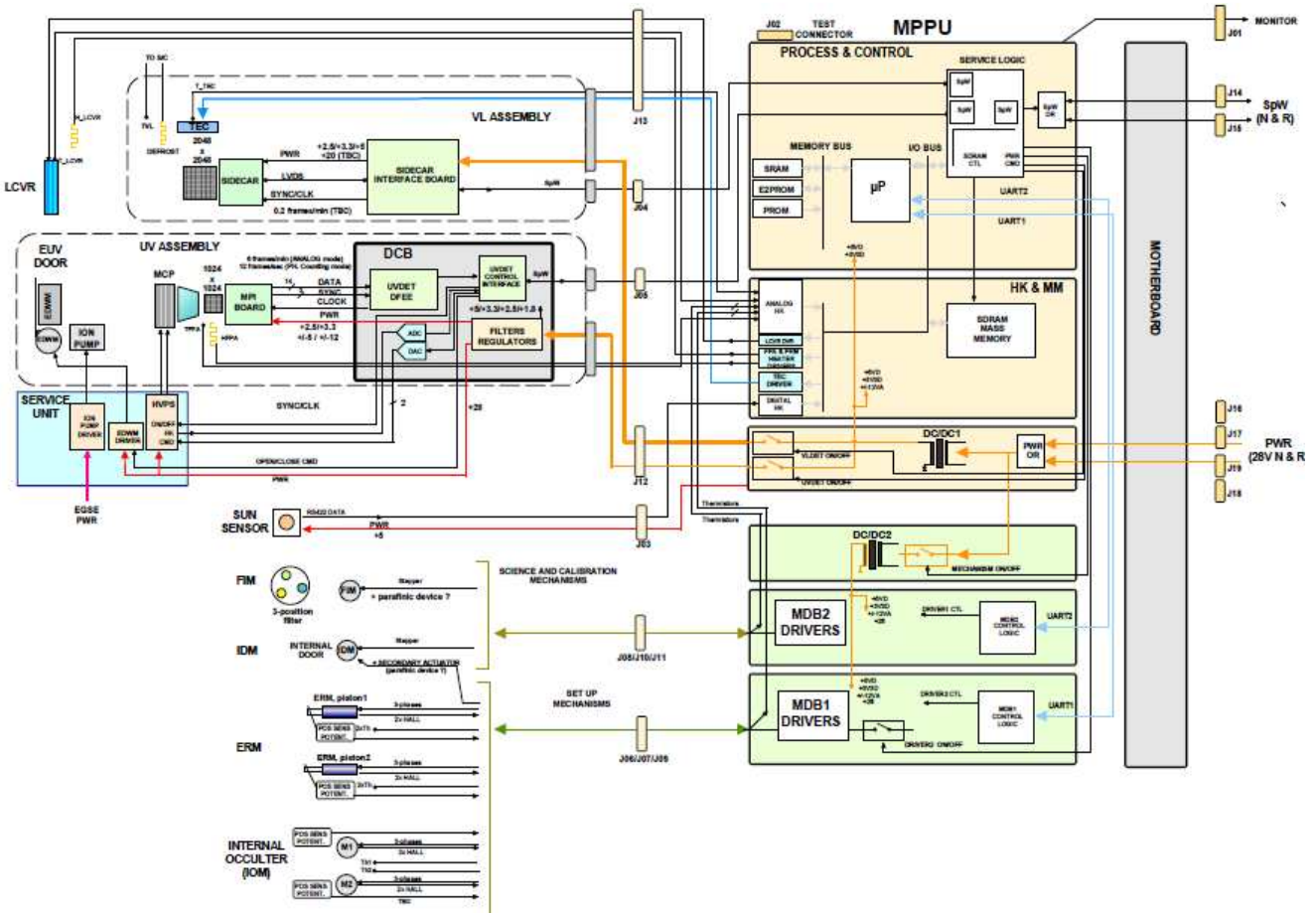

Fig. 3 METIS electronics block diagram showing the MPPU, detector assemblies and subsystems (courtesy of Thales Alenia Space Italia)

The MPPU electronics is located close to the METIS optical bench to avoid instrument mass increase due to long and heavy harness and to drive and collect noiseless analog and digital signals.

It hosts the following electronics boards:

- 1 Processing and Control (CPU) board;
- 1 Housekeepings (HKs) collection and Mass Memory (MM) board;
- 2 DC/DC power supply boards;
- 2 Mechanisms driver boards;
- 1 Motherboard or backplane, hosting connectors.

These boards are hosted inside the MPPU unit made of aluminum and fixed to the box by means of flight-qualified

based on the Extended Double Eurocard standard format -as baseline- except for the Motherboard, which will be smaller.

In order to correctly operate the instrument and achieve the overall scientific goals METIS hosts some mechanisms, as described later, driven by two dedicated boards that communicate with the processing board via two UART (serial) links.

The processing and control board hosts a space-qualified processor and a service logic implemented in a rad-hard FPGA like the RTAX2000S model from ACTEL (as baseline) or an ASIC developed by THALES Alenia Space Italia (EPICA or EPICA NEXT ASIC). The service logic acts as data and commanding IF to METIS subsystems and to the spacecraft as it implements at least 4 SpW links, 2 for the detectors subsystems and 2 (N+R, in OR configuration) for the

spacecraft. It also hosts a mass memory (SDRAM) controller in order to manage memory aboard the HKs and MM board. The processor, a LEON2FT (SPARC V.8 architecture) as baseline, is interfaced to the service logic and other subsystems hosted in the HKs & MM board by means of an I/O internal bus and to the all memories (PROM, E2PROM, SRAM) thanks to a memory bus, that make the overall processing architecture well structured and versatile.

The processing board is responsible for the detectors and mechanisms subassemblies commanding and control, whereas the mechanisms boards hosts just the low-level drivers for actuators and feedback positioning measurements. It is also responsible for the Sun Sensor commanding and control as well for the overall telemetry and telecommands management, data collecting, processing, compression and data management (SpW protocol management, data packetization).

The processor, with the support of the SRAM memory, runs the Real Time Operating System (the candidate OS is VxWorks 6.3) and the METIS Application SW once the bootstrap process is concluded. The boot process involves two low-level SW subsystems hosted in a PROM and in an E2PROM, the BIOS SW and the BOOT SW. The former is responsible for allowing the access to all MPPU internal hardware and external data communication channels and I/Os, while the latter is responsible for the initialization and for the E2PROM patch and dump safe procedures ending with the full SRAM testing and ASW loading and initialization, bringing the instrument in the Stand-by operative mode (Fig. 4).

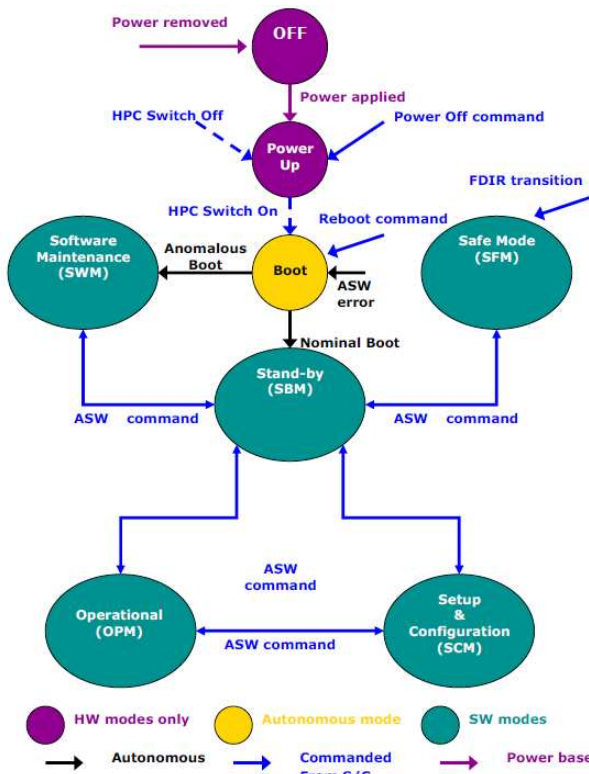

Fig. 4 METIS Operative Modes and the bootstrap procedure ending in the Stand-by mode (courtesy of Thales Alenia Space Italia)

The HKs & MM board is equipped with a dedicated rad-hard FPGA to perform autonomously HKs collection coming from temperature, current and voltage sensors distributed inside the overall MPPU unit and external subsystems. This logic could be also used to implement some automatic function (e.g. memory scrubbing) in the MM section within the same board.

Two distinct DC/DC boards are foreseen to provide power supply and secondary level voltages to all subsystems along with the generation of the secondary voltage lines required for the MPPU internal boards (Fig. 5).

DC/DC boards receive from the spacecraft power bus the primary voltage supply by means of two (N+R) distinct +28V power lines and host several input and output current and voltage protections as well as EMI filtering for EMC cleanliness.

Finally, the MPPU is equipped with two boards to drive the METIS mechanisms. These boards host the mechanisms control logic in a FPGA and/or a dedicated ASIC controller implementing a command decoder in order to decode instructions and commands coming from the processor.

While Thales Alenia Space (Torino, Italia) is responsible for the overall METIS (MOU and MPPU) design, Selex Galileo (Firenze, Italia) will provide the mechanisms and their driver boards.

The MPPU nominal power consumption (without mechanisms activation) according to the present design is about 16 Watts; it has a mass below 6 Kg and its dimensions are 250mm L x 250mm W x 150mm H (feet excluded).

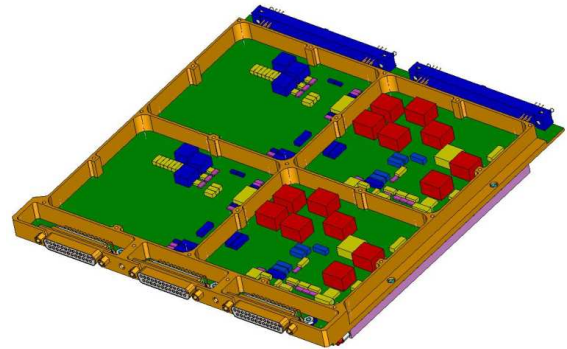

Fig. 5 MPPU electronics boards layout (courtesy of Thales Alenia Space Italia)

IV. ON BOARD PROCESSING AND DATA HANDLING

The METIS instrument on-board data processing is a distributed task, involving many subsystems like the detector's proximity electronics and IF boards and the ASICs and/or FPGAs aboard the MPPU, however, the overall instrument control and data processing tasks are managed by the LEON Processor [13] running the ASW and managing the operative modes. The ASW is in charge of the Fault Detection Isolation and Recovery (FDIR) procedures and transitions, managed by the operational Safe Mode (Fig. 4), in order to operate safely the instrument. ASW also manages all the telecommands received by the OBC in order to implement both the autonomous in-flight operations and the execution of possible

commands sent by the ground segment. Every commands received by the S/C is checked and validated before its execution. When operating in photon counting mode, the UV/EUV detector proximity electronics produces a continuous digital data stream with packets mainly providing the position information of the event and the integrated charge amplitude as well. These data are collected by the MPPU and stored on the MM board without a meaningful processing (only a low compression factor can be achieved with this data format). In analog mode the analog data produced by each detector are read out and converted into digital signal by the detector proximity electronics hosting the ADCs. Then they are transferred to the MPPU through a SpW links.

The received data are processed by the CPU in order to reduce the data volume operating masking, windowing and binning, then are packetized in compliance to the ECSS format (E-70-41A, "Telemetry and Telecommand Packet Utilization Standard") [14] and finally stored into the internal MM waiting for the S/C download. Finally, when the UV/EUV detector is operating in accumulation mode, the MPPU produces a 2Kx2K image at 10-bits of resolution, mapping and stacking at half-pixel level each received event.

The overall data volume has to be reduced in order to find a compromise between the allocated resources for METIS and the OBC, in term of mass memory availability and S/C telemetry capabilities. The METIS instrument has in fact a limited available bandwidth towards the S/C and a precise overall amount of mass memory (26 Gbit/orbit) aboard OBC, therefore the CPU has to run algorithms capable of performing an efficient data reduction.

In order to match the available bandwidth and limit the data volume, an overall compression ratio of the order of 10:1 has to be reached, possibly minimizing information losses.

Thanks to the characteristics of the images provided by METIS (Fig. 6) this compression ratio can be achieved combining masking, binning and pure compression. In fact METIS VIS channel produces just simple coronal polarized images with a large part of the frame not scientifically useful (the central part reproducing the occulter disk), while the UV/EUV channel produces a superposition of the coronal Ly α image with the spectra provided by the slits and the diffraction grating in a black region (i.e. the missing part of the corona, corresponding to the diffraction grating shadow) [15]. So the image portion not reproducing any scientific information can be rejected by means of digital masking processing, while the parts containing the solar corona and the spectra need to be encoded with very high quality, possibly without information losses. The solar corona itself can be compressed with different degrees of quality. The quality must be higher towards the solar limb, as these brighter image portions collect more information than those towards the image's edges [16]. Nevertheless it is possible to increase the S/N ratio at the edge of the images operating pixel binning, despite spatial resolution. Anyway in order to reach high compression factors we presumably need the development of algorithms capable of performing radial compression with different quality degrees, combined with digital masking. A possible way is to take advantage of the wavelet-based CCSDS Image Data Compression recommendations and/or the JPEG 2000 image compression standard, also based on wavelets.

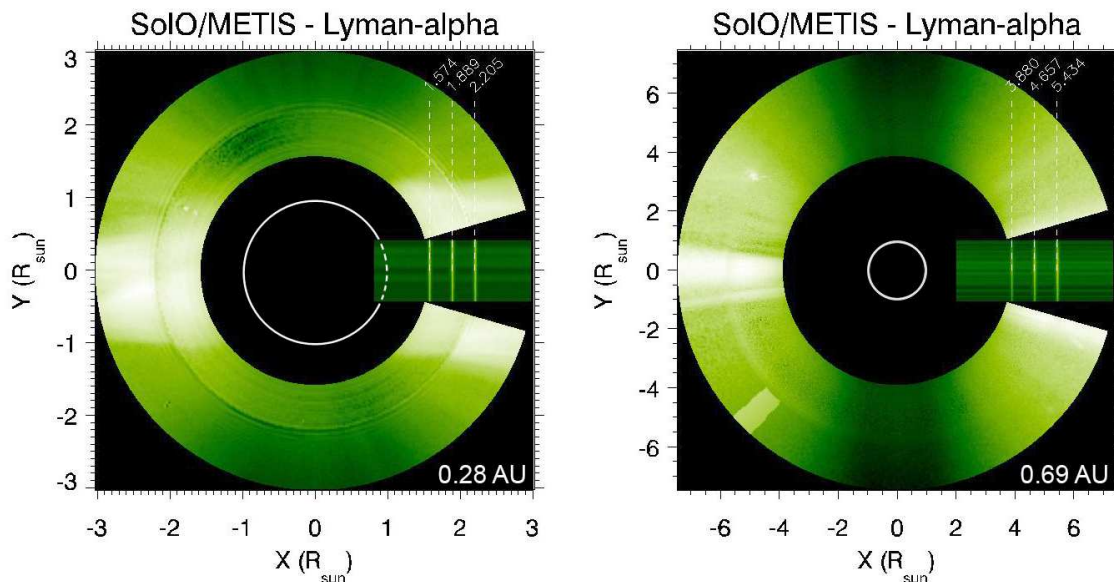

Fig. 6 METIS UV/EUV channel simulated images of the solar corona during the nominal mission's first orbit. Left: instrument's perihelion field of view @ 0.28 AU. Right: instrument's highest helio-latitude field of view @ 0.69 AU. The white circles represent the apparent diameter of the Sun, while the rectangle area on the right sides is the spectra produced by slits and diffraction grating

V. MECHANISMS MANAGEMENT

The MPPU is also in charge of mechanisms driving and management. METIS hosts, in fact, 6 mechanisms and a Sun Sensor in order to safely operate the coronagraph in case of S/C off-pointing, preventing the direct Sun disk light from entering the telescope. In addition to the coronagraph's external aperture door mechanism, which is operated by the S/C, METIS is equipped with the following mechanisms:

ERM is the External Repointing Mechanism for small instrument angular movements ($\pm 1.4^\circ$) in order to correctly point METIS to the Sun center in case of S/C off-pointing, exploiting the feedback information provided by the Sun Sensor. It is based on two perpendicular actuators or pistons and a flexible hinge pivot.

IOM is the Internal Occulter Mechanism, used for the alignment of the internal occulting disk compensating for possible post-launch mechanical misalignments and in-flight calibrations.

FIM is the Filter Insertion Mechanism, a precision three positions mechanism hosting a dielectric filter for combined VIS-UV observations and two Aluminum filters (N+R) for EUV imaging and spectroscopy.

EDWM is the EUV Detector Window Mechanism, a two-position mechanism required to open the internal vacuum tight window of the EUV detector and preserve its functionality until launch.

LCVR is the Liquid Crystal Variable Retarder [17], a component of the polarimeter assembly. Liquid crystal plates replace the classical mechanically rotating retarders with electro-optical devices based on nematic crystals, characterized by birefringency phenomena by applying an amplitude modulated -and balanced- voltage square wave.

IDM is the Internal Door Mechanism, a two-positions neutral density filter door that internally closes the METIS entrance aperture. It is aimed at the preservation of the instrument cleanliness and it will be used for calibrations purposes and to protect the detectors in case of a large Sun center misalignment. It will be useful during on-ground operations and calibrations to avoid external contaminants from entering the instrument and degrading the METIS subsystems.

The electronics drivers for ERM, IOM, FIM and IDM are hosted in two dedicated boards inside the MPPU, while the LCVR electronics is located in the HKs & MM board. Depending on the EDWM driver complexity its control electronics can be implemented inside the HKs & MM board or in the Service Unit.

VI. IN-FLIGHT CALIBRATIONS

After the on-ground calibrations campaign and the commissioning phase following the Solar Orbiter launch, scheduled in 2017, METIS mechanical and opto-electronics subsystems should be checked and calibrated for in-flight scientific observations. These operations should be performed once per each ten-days observing window, involving mainly

the detectors electronics, the MPPU and the Internal Door Mechanism. Once are checked the Internal Occulter alignment and the basic detectors functionalities, VIS and UV/EUV dark images should be taken by closing the internal door and inserting the Helium (Al) filter. After dark images, the VIS light detector vignetting function as well as the detector flat field should be measured and some radiometric calibrations on VIS and UV/EUV detectors must be performed, by exploiting the transits of UV bright stars along the instrument field of view. Also for the UV/EUV detector a sort of flat field calibration is foreseen with the internal door opened, the Al filter inserted and a slight IOM off-centering, thus allowing for a sufficient UV/EUV light flux entering the instrument.

VII. CONCLUSION

This paper provides an overview on the current status of the METIS Coronagraph aboard the ESA Solar Orbiter Mission and on its overall data processing architecture. At the present time some questions concerning the MPPU electrical configuration and its processing capabilities are still open. In particular it is essential to estimate the needs for CPU resources in terms of basic instructions per unit of time (MIPS) in order to efficiently address all the service tasks and scientific issues, as well as the instrument's Mass Memory amount and the processor's compression algorithm efficiency. These still open questions should be addressed before the ESA Instrument's Preliminary Design Review that will be held in April 2012.

ACKNOWLEDGMENT

The Author would like to thank Thales Alenia Space Italia (centers of Torino and Milano) and Selex Galileo (centers of Firenze and Milano) for their continuous support in the METIS electronics and subsystems design, resources and characteristics definition, as well for all the managerial and programmatic aspects during the Definition Phase of the Solar Orbiter Mission, in the framework of ESA's Cosmic Vision program 2015-2025. The Author would also like to thank the METIS Scientific Team in supporting the instrument's design and the Italian Space Agency for its technical and financial support.

REFERENCES

- [1] F. Bernhard et al., "10 years of SOHO", ESA Bulletin, No. 126, p. 24 – 32, May 2006.
- [2] Tarbell, Theodore D. et al., "Fundamental Solar Physics Results from Hinode and the Solar Dynamics Observatory", Bulletin of the American Astronomical Society, Vol. 41, p.869, May 2010.
- [3] M. L. Kaiser et al., "The STEREO Mission: An Introduction. Space Science Reviews", 136:5, April 2008.
- [4] ESA/SRE, "Solar Orbiter, Assessment study report", December 2009.
- [5] S. Fineschi et al, "Ultraviolet and visible-light coronagraphic imager (UVCI) for HERSCHEL (helium resonance scattering in corona and heliosphere)", Proc. SPIE, Vol. 4853, 2003.
- [6] G. Nalletto et al, "METIS, the Multi Element Telescope for Imaging and Spectroscopy for the Solar Orbiter mission", proc. of ICSO Conference, Oct. 2010.
- [7] S. Fineschi, "Inverted-COR: Inverted-Occultation Coronagraph for Solar Orbiter", Technical Note n. 119, Osservatorio Astronomico di Torino,

- (http://www.oato.inaf.it/biblioteca/it/servizi/TechRep119_Fineschi.pdf), May 2009.
- [8] S. Fineschi, "Novel Optical Designs for Space Coronagraphs: Inverted Occulters and Lyot-stops", proc. of ICSO Conference, Oct. 2010.
 - [9] M. Pancrazzi, M. Focardi et al., "The Solar Orbiter METIS Coronagraph data signal processing chain", Proc. of SPIE Vol. 8167 81672C-1, 2011.
 - [10] Y. Bai, "Teledyne Imaging Sensors: Silicon CMOS imaging technologies for x-ray, UV, visible and near infrared", SPIE Conference, 7021-01, 2008.
 - [11] M. Loose et al, "SIDE CAR ASIC –control electronic on a chip", Scientific Detectors for Astronomy 699-706, 2005.
 - [12] Eberhardt E.H., "Gain model for microchannel plates" - Appl.Opt. 18 (1979) 1418.
 - [13] Atmel, "AT697E: Rad-Hard 32 bit SPARC V8 Processor", Atmel datasheet.
 - [14] ESA-ESTEC, ECSS-E-70-41A standard.
 - [15] A. Bemporad, "Simulation of H Lyman- α images for the METIS coronagraph", Technical Note, METISOATO-TNO-002, 2010.
 - [16] V. Andretta et al, "Coronal Radiances and Modelling", METIS-OACT-TNO-004, Technical Notes, 2011.
 - [17] S. Fineschi, et al, "KPol: liquid crystal polarimeter for K-corona observations from the SCORE coronagraph", Proc. SPIE, Vol. 5901, 389-399, 2005.

Mauro Focardi is a Ph.D. working at the Department of Physics and Astronomy of the University of Florence, where he is involved in the field of technology and instrumentation for space and ground-based Astrophysics, FPA sensors, detectors readout electronics and instrument control units for payloads aboard scientific satellite platforms.