

Coordinated Q–V Controller for Multi-machine Steam Power Plant: Design and Validation

Jasna Dragosavac, Žarko Janda, J.V. Milanović, Dušan Arnautović

Abstract—This paper discusses coordinated reactive power - voltage (Q-V) control in a multi machine steam power plant. The drawbacks of manual Q-V control are briefly listed, and the design requirements for coordinated Q-V controller are specified. Theoretical background and mathematical model of the new controller are presented next followed by validation of developed Matlab/Simulink model through comparison with recorded responses in real steam power plant and description of practical realisation of the controller. Finally, the performance of commissioned controller is illustrated on several examples of coordinated Q-V control in real steam power plant and compared with manual control.

Keywords—Coordinated Voltage Control, Power Plant Control, Reactive Power Control, Sensitivity Matrix

I. INTRODUCTION

THE coordinated reactive power - voltage (Q-V) control at the plant level performs the reactive power (Q) allocation among plant generators in order to maintain plant terminal voltage at desired level. This allocation is traditionally done by the plant operator according to economic or technical criteria: proportionally to generators rated power, reactive margin or power factor, etc. [1]. It is very difficult however, for the plant operator to combine simultaneously and adequately different factors, e.g., generator operating chart (D diagram), price of each generator's MWh and synchronous generator (SG) losses while trying to maintain plant terminal voltage and deliver required Q to the system. The focus on increasing energy efficiency means that losses in the SG have to be minimized. Since losses in the field winding dramatically change with the change in delivered Q (e.g., the losses in the field winding of 367MVA generators of the steam power plant (SPP) considered in this study increase 48% when Q generation is varied from $Q=0$ to rated $Q=Q_{\text{rated}}$), loss minimization of the power plant is achieved if total generated Q is shared equally (based on operating chart and operating point) among participating generators.

Uniform allocation of Q among the participating generators in the plant (coordinated Q-V control) also leads to minimization of losses due to reactive current production, uniform aging of the machines, better support to the system voltage profile for slow voltage variations and better dynamic Q support to different perturbations and contingencies in power system.

This paper presents design approach to coordinated Q-V controller and validation of controller performance in a multi machine steam power plant.

Jasna Dragosavac, Zarko Janda and Dušan Arnautović are with Electrical Engineering Institute "Nikola Tesla", 11000 Belgrade, Serbia (e-mail: jasna.dragosavac@ieent.org, zarko.janda@ieent.org.).

Jovica V. Milanovic is with The University of Manchester, Manchester M13 9PL, UK (e-mail: milanovic@manchester.ac.uk).

II. DRAWBACKS OF MANUAL Q-V CONTROL

Manual power system control involves dispatching the SG's forecasted reactive power, scheduling the power plants' terminal voltage, switching the banks of shunt capacitors and changing voltage set points of on load tap changers (OLTC) and flexible AC transmission system (FACTS) devices.

The major disadvantages of manual reactive power voltage control (see Fig. 1) are:

- Dispatching and scheduling are performed based on forecasting (off-line) and are often different from real P and Q requirements (detail 1 and 2 in Fig. 1);
- Dispatching and scheduling follow forecasted P and Q demands or the requirements of system operator when he observes the difference between forecasted value and actual system requirements (detail 3 in Fig. 1);
- There is no connection to system dynamics;
- When the operation of the system is automated at higher hierarchical levels, the manual control of generators within the plant becomes inadequate.

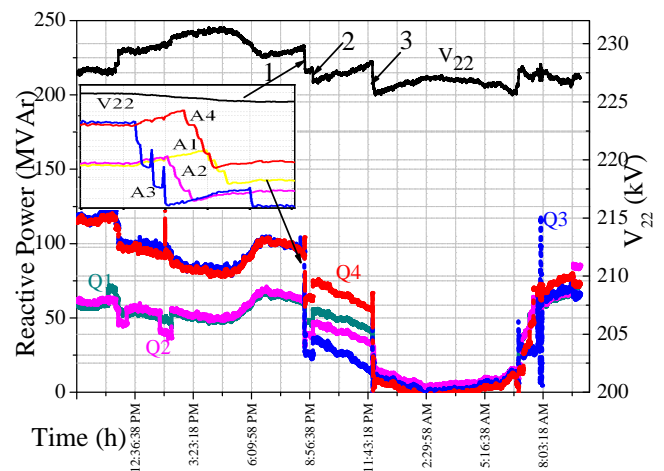

Fig. 1 Daily diagram of HV bus and generated reactive power in SPP (top curve- HV bus voltage; bottom curves – generated Q by individual SGs): 1-System operator (SO) demands reduction of Q according to forecasted daily diagram, Zoomed detail: Q hunting among the SGs in the plant occurs; 2 -SPP reactive power hunting between electrically close power plants. At this point SO demands reduction of Q at nearby SPP; 3-Additional SO action to compensate for non-forecasted voltage raise: A1 (cyan solid), A2 (violet dashed), A3 (blue dotted) and A4 (red dash dotted), V_{22} (black solid)

An example of manual control of a steam power plant (SPP) generated Q and high voltage (HV) bus voltage (V_{22}) is illustrated by daily diagram in Fig. 1 recorded at a real SPP. The single line diagram of the SPP is shown in Fig. 2. From noon till 4PM, the load in the system is gradually reducing and all voltages, including the HV bus voltage at the point of plant connection (top curve V_{22} in Fig. 1), are

rising. The HV bus voltage is regulated partially by the automatic voltage regulators (AVR) action, reflected as lower generated Q. At 8:40PM the system operator demanded to reduce the total generated Q. The SPP dispatcher then dispatched the total Q to participating SG with different time delay (introduced by locations of generators and communications with individual unit operators) as shown in inset in Fig. 2 (zoomed transient at point 1). This led to Q hunting among the SGs. Point 2 illustrates a decrease in Q generation at the nearby power plant resulting from the system operator's demand to adjust Q generation in the system. This is followed by a Q generation increase at the test SPP due to the action of the AVR. Therefore, the initially reduced Q output, (point 1) is partly compensated by unwanted actions at point 2. Finally point 3 represents the system operator additional request for Q reduction after voltage rise in the power system was observed.

III. DESIGN REQUIREMENTS FOR COORDINATED Q-V CONTROLLER

The main purpose of SPP coordinated Q-V controller is to maintain the voltage at HV bus (plant connection point) in real time by SGs in the plant in automatic and coordinated manner.

The controller should meet the following requirements:

- i) Q control loop should not be closed on a single SG to avoid the problems with overlapping (unlike early EDF [2], Italy [3], Korea [4], etc);
- ii) The sensitivity matrix concept should be applied on SPP level in order to decouple parallel synchronous generator operation and achieve faster and better Q allocation. (The elements of sensitivity matrix are SG and step-up transformer reactances and network reactance.);
- iii) Network reactance changes in time so real time network reactance estimation is needed. With the better estimation of sensitivity matrix, better decoupling between the participating units is achieved. Faster and more accurate Q allocation leads to better voltage support;
- iv) Q allocation should be performed according to available Q reserves of individual SGs;
- v) HV bus voltage should be controlled with required droop to suppress interactions with the neighbouring plants;
- vi) There should be no modification nor interference with existing AVRs;
- vii) It should provide unified response of different types of generators and excitation;
- viii) It should perform the voltage control as fast as possible but with variable minimal time delay to reach the steady state operating point of each synchronous generator involved.

IV. CONTROLLER DESIGN

A. Model development

The equivalent single line diagram of the plant and the associated network is shown in Fig. 2. Units A1 to A6 are SG represented as emf (E_{qi}) behind the synchronous reactance X_{gi} . The step-up transformers (T1 to T6) are represented by reactances X_{bi} . Each generator is connected to the bus through the step-up transformer. Four (out of six) generators (A1, A2, A3 and A4 shown in Fig. 2) within the plant are connected to 220kV busbar (V_{22}) and the other two (A5 and A6, shown in Fig. 2) to 400kV busbar (V_{40}). The plant is connected to 220kV network (V_{M22}) represented with E_{22} and reactance X_{22} and to 400kV network (V_{M40}) represented with E_{40} and reactance X_{40} . The 220kV and 400kV busbars are connected via transformers T11 and T12.

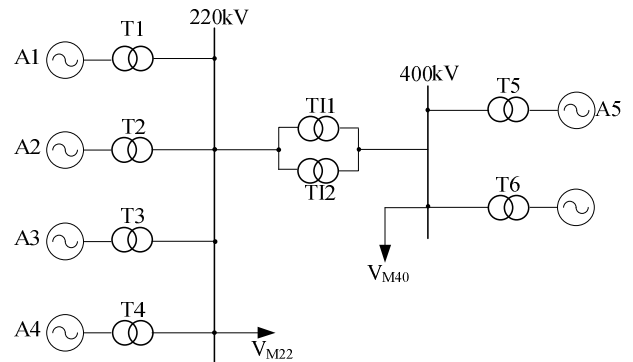

Fig. 2 The simplified internal equivalent single line diagram of the steam power plant "Nikola Tesla A"

Several field tests were performed at different operating points having different real power (P) levels of units and different power factor ($\cos\phi$) in order to determine:

- i) the Q_{step} value for each generator and variations of Q_{step} for different operating points;
- ii) the degree of coupling between the units connected to the same HV bus (220kV and 400kV);
- iii) the degree of coupling between the units connected to different HV buses
- iv) the model of the generator with its excitation system.

The injected apparent power of the generator is given by [5]

$$\underline{S}_{Gi} = V_{Gi} \underline{I}_{Gi}^*, \quad i = 1, 2, \dots, N_{GI} \quad (1)$$

where V_{Gi} is generator voltage and I_{Gi}^* is generator current of i -th unit.

According to (1), the node-injected active and reactive power are given by

$$P_{Gi} = V_{Gi}^2 Y_{Gii} \sin(\mu_{Gii}) + \sum_{\substack{j=1 \\ j \neq i}}^{N_{Gi}} V_{Gi} V_{Gj} Y_{Gij} \sin(\delta_{ij} - \mu_{Gij}) \quad (2)$$

$$Q_{Gi} = V_{Gi}^2 Y_{Gii} \cos(\mu_{Gii}) - \sum_{\substack{j=1 \\ j \neq i}}^{N_{Gi}} V_{Gi} V_{Gj} Y_{Gij} \cos(\delta_{ij} - \mu_{Gij}) \quad (3)$$

where Y_{Gij} and μ_{Gij} are the magnitude and phase angle of the admittance \underline{Y}_{Gij} , respectively and $\delta_{ij} = \delta_i - \delta_j$ is the angle difference between voltage phasors of nodes i and j .

In order to estimate (during the steady state operation) change in the active and reactive power of all generators in the network of interest caused by the change of generator voltages the following linearized matrix equations are used [6]:

$$\Delta \mathbf{P}_G = \left(\frac{\partial \mathbf{P}_G}{\partial \mathbf{V}_G} \right) \Delta \mathbf{V}_G, \quad (4)$$

$$\Delta \mathbf{Q}_G = \left(\frac{\partial \mathbf{Q}_G}{\partial \mathbf{V}_G} \right) \Delta \mathbf{V}_G, \quad (5)$$

where $\Delta \mathbf{V}_G$ is vector of generator voltage changes; $\Delta \mathbf{P}_G$ is vector of injected active power changes caused by generator voltage changes; $\Delta \mathbf{Q}_G$ is vector of injected reactive power changes caused by appropriate generator voltage changes; $\partial \mathbf{P}_G / \partial \mathbf{V}_G$ and $\partial \mathbf{Q}_G / \partial \mathbf{V}_G$ are square matrices of real and reactive power sensitivity, respectively. In case of reactive power sensitivity matrix, the $\partial \mathbf{Q}_G / \partial \mathbf{V}_G$ has the following elements:

$$\frac{\partial Q_{Gi}}{\partial V_{Gi}} = 2V_{Gi} Y_{Gii} \cos(\mu_{Gii}) - \sum_{\substack{j=1 \\ j \neq i}}^{N_{Gi}} V_{Gj} Y_{Gij} \cos(\delta_{ij} - \mu_{Gij}), \quad (6)$$

for $i = 1, 2, \dots, N_{Gi}$

$$\frac{\partial Q_{Gi}}{\partial V_{Gj}} = -V_{Gi} Y_{Gij} \cos(\delta_{ij} - \mu_{Gij}), \quad (7)$$

for $j = 1, 2, \dots, N_{Gj}, j \neq i$

Thus, applying the equations (6) and (7), after determining voltage changes of selected generator, the corresponding changes of real ($\Delta \mathbf{P}_G$) and reactive ($\Delta \mathbf{Q}_G$) power can be obtained.

In case of reverse problem definition, i.e., determining voltage variation caused by changes in generator real and reactive power, the corresponding linearized matrix equations are formulated as:

$$\Delta \mathbf{V}_G = \left(\frac{\partial \mathbf{P}_G}{\partial \mathbf{V}_G} \right)^{-1} \Delta \mathbf{P}_G, \quad (8)$$

$$\Delta \mathbf{V}_G = \left(\frac{\partial \mathbf{Q}_G}{\partial \mathbf{V}_G} \right)^{-1} \Delta \mathbf{Q}_G. \quad (9)$$

In the above formulation the external power network is represented using Thevenin equivalent. The equivalent Thevenin network impedance can be assumed to be pure inductance without any loss of generality. Based on equation (5) and equivalent single line diagram of the plant and associated network, e.g., as shown in Fig. 2 for the test case power plant, the sensitivity matrix (\mathbf{S}) can be obtained as

$$\Delta \mathbf{Q}_G = \mathbf{S} \cdot \Delta \mathbf{V}_G. \quad (10)$$

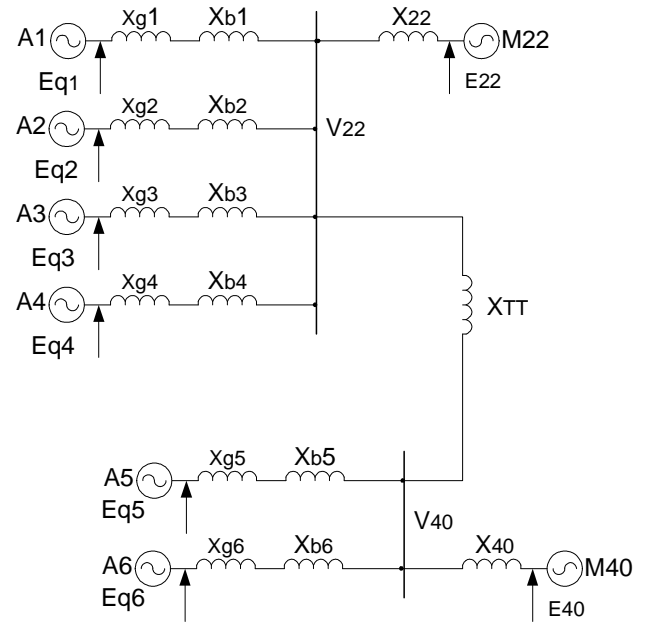

Fig. 3 Simplified internal equivalent single line diagram of the steam power plant "Nikola Tesla A"

Following allocation of reactive power changes to each unit, the necessary reactive power increments (steps) are determined and the corresponding changes of generator reference voltages can be found using the following relationship

$$\Delta \mathbf{V}_G = \mathbf{S}^{-1} \cdot \Delta \mathbf{Q}_G. \quad (11)$$

The inverse sensitivity matrix (\mathbf{S}^{-1}) can be easily calculated, from single line diagram shown in Fig. 1. (Note: In this particular case, Fig. 1 shows the internal power circuits of the steam power plant "Nikola Tesla A". The plant consist of six generators connected to two high voltage buses, one rated at 235 kV (V_{22} , Fig. 2) and the other at 407 kV (V_{40} , Fig. 2). Rated power of the generators A1 and A2 is 247 MVA, while the remaining four generators are rated at 367 MVA. The E_{qi} ($i=1-6$) is the equivalent EMF (internal voltage) of the i -th generator, equal to reference generator voltage, X_{gi} ($i=1-6$) is the equivalent reactance of the i -th generator (all feedbacks included) and X_{bi} ($i=1-6$) is the corresponding generator transformer reactance.) The elements of \mathbf{S}^{-1} can be directly obtained from generator and transformer parameters by using simple relationships. The only uncertain value is the equivalent Thevenin reactance of power network (235kV and 407 kV networks in this particular case) which can vary with time. One of basic assumptions in this research is that reactance variation with time is slow enough and that it can be considered as quasi-stationary value. The way to overcome this inaccuracy is to estimate power network reactance value by averaging several consecutive measured values. Each individual value is derived as the ratio of the change in p.u. value of voltage (at the HV winding of transformer) and the change in p.u. value of reactive power injected into the network. In order to achieve adequate performance of the algorithm it is necessary to predefine the lower and upper limits of the estimated reactance value. In this way smooth changes of the estimated Thevenin network reactance with time can be obtained. While applying equations (6) and (7) to the

equivalent single line diagram shown in Fig. 2, the following assumptions are made: i) All V_{Gi} voltage magnitudes are equal to unity; ii) All cosine functions are considered to be equal to one [6]. As a consequence of these assumptions, the elements of sensitivity matrix are composed of reactances only. One has to be aware though that this is a linearized model of the actual power network which is strictly valid within small area around actual operating points of the synchronous generators involved in P-Q space. Nevertheless, it is accurate enough for the intended purpose. After applying equation (11), the changes of generator voltage references are obtained. They are applied as up or down pulses for each reference voltage, where pulse duration is proportional to calculated pulse weight. In an ideal linear case one correction step, i.e., one up or down step in reference voltage set point, would be sufficient to achieve desired reactive power distribution. Unfortunately, this is a rare case in practice. To overcome the linear model limitations and to make the proposed reactive power control algorithm robust and insensitive to inevitable changes in operating environment and generator active power influence, it is necessary to increase the number of control steps. At least two steps are necessary for the use of predictor-corrector approach [7], [8] employed in this study. The original algorithm is therefore, modified in such a way that the steps in reference voltage of the first generator are just a fraction of the value calculated using (11). The first applied voltage step is effectively determined by (12),

$$\Delta V_{G1} = \alpha \cdot \Delta V_G, \quad (12)$$

where ΔV_G is the step calculated according to (11) while $0 < \alpha < 1$ is appropriate weighting e.g., $\alpha = 0.85$. The value of parameter α is chosen by observing the worst case overshoot in recorded reactive power responses. A good rule of thumb is to choose the value of α as a difference between unity and maximal observed p.u. reactive power overshoot. The reactive power increment vector is then given by (13). The reactive power increment vector applied to controller is designated as $\Delta Q_{G1,real}$.

$$\Delta Q_{G1} = S \cdot \Delta V_{G1}. \quad (13)$$

After this small modification it is possible to scale reactive power response amplitudes for each generator as the ratio between expected and realized response as shown by (14),

$$\beta_i = \frac{\Delta Q_{G1,i}}{\Delta Q_{G1,real,i}} \quad i = 1, 2, \dots, 6. \quad (14)$$

In the next step of the algorithm the calculated increments of Q for each generator are multiplied by corresponding factor β obtained from (14). Such adjusted Q increments are then further processed by applying (11) so that the resulting error is smaller than predefined threshold. In this way appropriate modification of diagonal elements of the S^{-1} is achieved. The implicit assumption here is that the diagonal elements of S^{-1} are more significant than the rest of matrix elements, i.e., that the plant generators are not strongly

coupled. The drawback of this approach, i.e., incremental change in reactive power and voltage steps, is that the number of steps of the algorithm and thus computation time increases. This however, is not critical for the problem that is being addressed since the basic reactive power control algorithm is executed every 10 to 20 seconds allowing plenty of time for the required calculations.

B. Model validation

Prior to practical application designed coordinated Q-V controller was modelled in Matlab/Simulink and comprehensive simulations carried out to validate its performance. The coordinated Q-V controller was applied to units A1 to A4 in Fig. 2 both in simulations and real power plant. The results of the simulations were compared with recorded responses at the plant in Fig. 4. Very good match of the two sets of results validates the developed model of the plant. The coordinated Q-V controller was initially required to change total generated reactive power at 220kV bus (Q_{HV}) from 352 MVar to maximum permissible value, 400MVar (detail 1), that SPP at 220kV bus could deliver. The maximum permissible delivered reactive power Q_{4max} by unit A4 was then changed from 130MVar to 120MVar (detail 2). Finally, a new step to $Q_{HV} = 339$ MVar (detail 3) was implemented. When operated on site, the coordinated Q-V controller acts through raise/lower commands of the AVR in steps of approximately 10 MVar. This limits the accuracy of coordinated Q-V controller and causes the slight difference in the reactive power responses of SGs recorded at the site and those obtained in simulation. In simulation the coordinated Q-V controller acts directly upon the AVR's voltage reference so a much finer accuracy can be achieved.

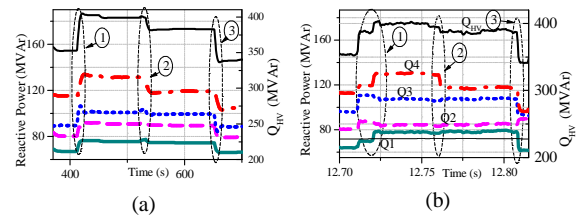

Fig. 4 Simulation results (a) and measured reactive power responses: for coordinated Q-V regulation at site (b): 1- Q_{HV} demand is changed from 352 MVar to 400 MVar; 2-Maximum permissible delivered Q_{4max} by unit A4 is changed from 130MVar to 120MVar; 3-- Q_{HV} demand is changed from 385 MVar to 339 MVar. A1 (cyan solid), A2 (violet dashed), A3 (blue dotted) and A4 (red dashdotted), V_{22} (black solid)

C. Practical realisation

The coordinated Q-V controller consists of central controller unit (CCU) and PC Terminal. The CCU is realized on programmable logic controller (PLC) based platform. Additional PLC module is used as the communication unit with the PC terminal in control room (SPP dispatching room) and the system operator (SO) in national transmission system control department. Digital inputs to the Q-V controller are: the positions of all generators circuit breaker and (tie) busbar breakers, and permission/prohibition from unit SCADA to include unit in coordinated Q-V control. Digital outputs include: command pulses signals up/down towards AVRs (six for each reference voltage up commands and six for each reference voltage down commands) and the ON /OFF information

signals which show whether the unit is included or not in coordinated Q-V control. In order to achieve simultaneous response of all units, Up/Down commands to the AVR are sent directly over DC voltage link (110VDC or 220VDC) to controlled unit and not over communication channel and SCADA. This avoids delays in communications and ensures minimal response time.

V. VALIDATION OF CONTROLLER PERFORMANCE

The results of coordinated Q-V controller after application in SPP are shown in following figures. Fig. 5 illustrates the difference in SPP responses under manual and coordinated Q-V control recorded at real SPP. The coordinated Q-V control resulted in flatter voltage (V_{22}) and SGs' reactive power responses. Changes in V_{22} that induce changes in Q responses of individual synchronous generators due to AVR action and manual control (Fig 6 and Fig. 7) are corrected by coordinated Q-V control (Fig 5).

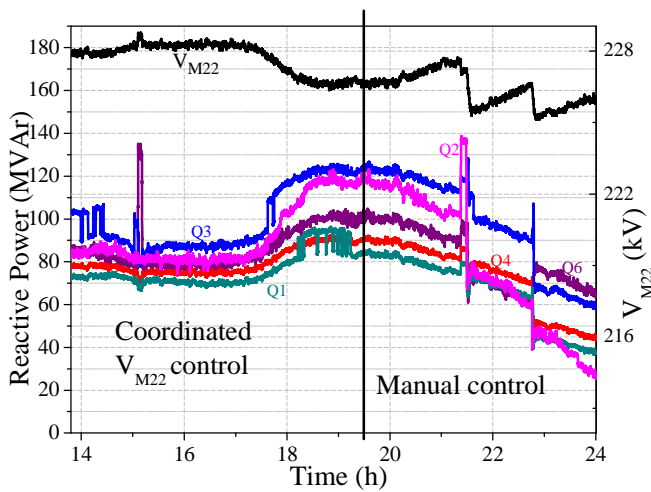

Fig. 5 Units A1 to A4 and V_{22} responses recorded under manual and Coordinated Q-V control: A1 (cyan solid), A2 (violet dashed), A3 (blue dotted) and A4 (red dashdotted), V_{22} (black solid). A6 response is added since it was temporarily connected to 220KV bus

Figures 6 and 7 illustrate recorded daily diagrams with manual Q-V control in the SPP performed by two different plant operators. Fig. 6 illustrates the case when the plant operator allocates reactive powers among units A1 to A4 according to SG's rated power (A1 and A2 are rated 247MVA and A3 and A4 are rated 367MVA). In the case illustrated in Fig. 7 the plant operator allocates reactive powers among units A1 to A4 equally (in MVar) without any regard to SG's rated power or generated real power.

It is evident from these figures that different manual control by different operators could lead to quite different, sub-optimal, plant performance with respect to HV bus voltage regulation and allocation of reactive powers among plant generators.

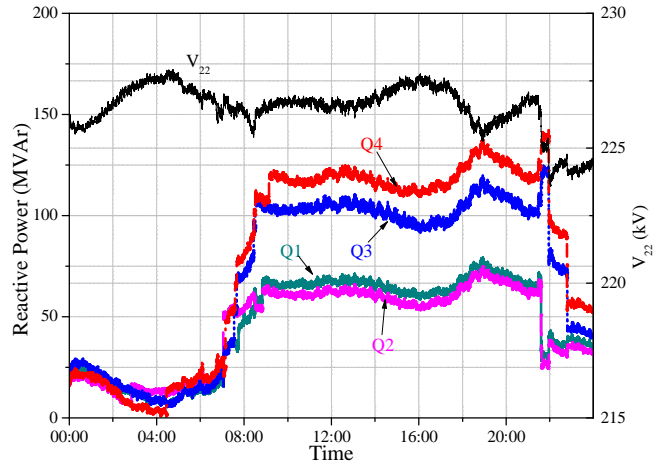

Fig. 6 Daily diagram of A1 to A4 and V_{22} responses under manual control. plant operator 1: A1 (cyan solid), A2 (violet dashed), A3 (blue dotted) and A4 (red dashdotted), V_{22} (black solid). A6 response is added since it was temporarily connected to 220KV bus

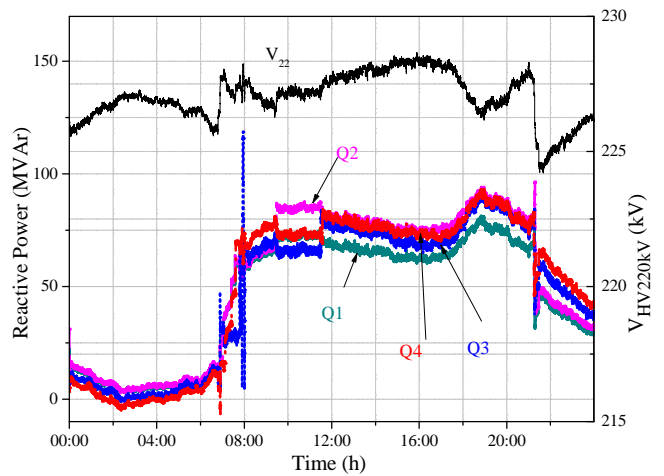

Fig. 7 Daily diagram of A1 to A4 and V_{22} responses under manual control. plant operator 2: A1 (cyan solid), A2 (violet dashed), A3 (blue dotted) and A4 (red dashdotted), V_{22} (black solid). A6 response is added since it was temporarily connected to 220KV bus

VI. CONCLUSIONS

Balancing the reactive margins as well as the simultaneous response of all generators in a power plant gives the best platform for power plant voltage support. However, this is not easily achieved through manual control by plant operator. By implementing coordinated Q-V control at power plant level both the power plant and power system would benefit. Apart from potentially being reimbursed for providing adequate voltage service to the system, uniform allocation of reactive power among the generators in the SPP performed by coordinated Q-V control leads to the minimization of losses due to reactive power production, uniform aging of the machines and maximal dynamic support to the system. The designed coordinated Q-V controller ensures appropriate allocation of the demanded reactive power among generators in the plant and provides the HV busbar voltage control with required droop to avoid (suppress) interactions with the neighbouring plants. The unified response of different types of generators and excitation systems is achieved and voltage control is performed as fast as possible but with variable, minimal,

time delay to reach the steady state operating point of each generator involved. In order to ensure complete decoupling with the AVR limiter action and excitation forcing, the coordinated Q-V controller is activated if, and only if, the system is in steady state. Both, the HV bus voltage and reactive power flows are checked for steady state detection prior to any coordinated Q-V controller action. In this way maximal benefits of both the AVR and coordinated Q-V controller are achieved. The coordinated Q-V controller effectively “adjusts” AVR’s reference voltage in steady state so that the system gets the maximum benefit of excitation system action during the disturbance.

REFERENCES

- [1] J. D. Hurley, L. N. Bize, C. R. Mummert, “The Adverse Effects of Excitation System Var and Power Factor Controllers, *IEEE Transactions on Energy Conversion*, Vol. 14, No. 4, pp:1636 – 1645 Dec. 1999.
- [2] P. Lagonotte, J. C. Sabonnadiere, J. Y. Leost, , J. P. Paul, “Structural analysis of the electrical system : application to the secondary voltage control in France,” *IEEE Transactions on Power Systems*, Vol. 2, pp. 479-484, 1989.
- [3] S. Corsi, M. Pozzi, C. Sabelli, A. Serrani, “ The Coordinated Automatic Voltage Control of the Italian Transmission Grid, Part II : Control apparatuses and field performance of the consolidated hierarchical system”, *IEEE Trans. on Power Systems*, November 2004, Volume 19, Number 4, pp 1733-1741.
- [4] W. Yu, H. Lee, D. Hur, C. Lim, T. Kim, J. Shin, S. Nam, Hybrid Intelligent Voltage and Reactive Power Control System for Jeju Power System in Korea, 8th WSEAS International Conference on Power Systems, Santander, Cantabria, Spain, September 23-25, 2008.
- [5] J. Machowski, J. W. Bialek, J. R. Bumby, *Power System Dynamics: Stability And Control*, , John Wiley & Sons, Chichester, 2008, pp 113 – 115.
- [6] John Grainger, Jr., William Stevenson, *Power System Analysis*, McGraw-Hill, 1994, p 369.
- [7] K. Iba, H. Suzuki, M. Egawa, and T. Watanabe, "Calculation of Critical Loading Condition with Nose Curve Using Homotopy Continuation Method," *IEEE Transactions on Power Systems*, vol. 6, 1991.
- [8] Ajarapu, *Computational Techniques for Voltage Stability Assessment and Control*, Iowa: Springer, 2006, pp 51 - 53.

Jasna Dragosavac received her Dipl.Ing. and M.Sc. degrees in Electrical Engineering from the University of Belgrade, in 1994 and 2002 respectively. Since 1995 she is with the Department of Automation and Control, Electrical Engineering Institute “Nikola Tesla”, Belgrade, Serbia. Currently she is also doing research towards her PhD degree at the University of Novi Sad, Novi Sad, Serbia.

Žarko Janda received his Dipl. Ing., M.Sc. and PhD degrees in 1984, 1989 and 2004 respectively, from the University of Belgrade, all in Electrical Engineering. Since 1984 he is with the Department of Automation and Control, Electrical Engineering Institute “Nikola Tesla”, Belgrade, Serbia.

Jovica V. Milanović (M'95, SM'98, F'10) received his Dipl.Ing. and his M.Sc. degrees from the University of Belgrade, Yugoslavia, his Ph.D degree from the University of Newcastle, Australia, and his Higher Doctorate (D.Sc. degree) from The University of Manchester, UK, all in Electrical Engineering. Currently, he is a Professor of Electrical Power Engineering and Director of External Affairs in the School of Electrical and Electronic Engineering at The University of Manchester, Manchester, UK and Visiting professor at the University of Novi Sad, Novi Sad, Serbia.

Dušan Arnautović received his Dipl. Ing., M.Sc. and PhD degrees in 1973, 1978 and 1988 respectively, from the University of Belgrade, all in Electrical Engineering. Since 1977 he is with the Department of Automation and Control, Electrical Engineering Institute “Nikola Tesla”, Belgrade, Serbia.