

Ethylene Epoxidation in a Low-Temperature Parallel Plate Dielectric Barrier Discharge System: Effects of Ethylene Feed Position and O_2/C_2H_4 Feed Molar Ratio

Bunphot Paosombat, Thitiporn Suttikul, and Sumaeth Chavadej

Abstract—The effects of ethylene (C_2H_4) feed position and O_2/C_2H_4 feed molar ratio on ethylene epoxidation in a parallel dielectric barrier discharge (DBD) were studied. The results showed that the ethylene feed position fraction of 0.5 and the feed molar ratio of O_2/C_2H_4 of 0.2:1 gave the highest EO selectivity of 34.3% and the highest EO yield of 5.28% with low power consumptions of 2.11×10^{-16} Ws/molecule of ethylene converted and 6.34×10^{-16} Ws/molecule of EO produced when the DBD system was operated under the best conditions: an applied voltage of 19 kV, an input frequency of 500 Hz and a total feed flow rate of $50 \text{ cm}^3/\text{min}$. The separate ethylene feed system provided much higher epoxidation activity as compared to the mixed feed system which gave EO selectivity of 15.5%, EO yield of 2.1% and the power consumption of EO produced of 7.7×10^{-16} Ws/molecule.

Keywords—Dielectric Barrier Discharge, C_2H_4 Feed Position, Epoxidation, Ethylene Oxide

I. INTRODUCTION

ETHYLENE OXIDE (C_2H_4O , EO) is a valuable chemical feedstock for many applications, including the manufacture of surfactants and detergents. The partial oxidation of ethylene to ethylene oxide, so-called ethylene epoxidation, has been of great interest in many global research works. The most widely used technique for ethylene epoxidation is catalytic processes using silver catalysts supported on low surface area alpha-alumina ($Ag/(LSA)\alpha-Al_2O_3$) [1]-[4]. Some previous researches have revealed that alkali and transition metals, especially cesium (Cs) [5]-[11], copper (Cu) [12]-[15], and gold (Au) [16]-[21], can provide the improvement of the EO selectivity. However the catalytic process has to be operated at a high temperature and high pressure, leading to high energy consumption and catalyst deactivation which needs both regeneration and replacement of the deactivated catalyst. To resolve and avoid these problems, the low-temperature plasma is considered to be an alternative technique for ethylene epoxidation.

Paosombat B., Suttikul T. and Chavadej S. are with the Petroleum and Petrochemical College, Chulalongkorn University, Pathumwan, Bangkok 10330, Thailand (e-mail: bun_pao@hotmail.com, tsuttikul@yahoo.com)

Chavadej S. is with Center for Petroleum, Petrochemicals, and Advanced Materials, Chulalongkorn University, Bangkok 10330, Thailand (phone: +66-2-218-4139; fax: +66-2-218-4139; e-mail: sumaeth.c@chula.ac.th)

Dielectric barrier discharge (DBD) is one kind of non-thermal plasma, which electrons on electrodes surface gain enough energy from applied voltage to overcome the potential barrier of metal surface electrodes [22]. Then, incoming reactants can be directly transformed to chemically excited or dissociated gaseous species by colliding with the energetic electrons in the plasma zone. The non-thermal plasma, in general, possesses non-equilibrium properties, either because the ion temperature is different from the electron temperature or because the velocity distribution of one of the species does not follow a Maxwell Boltzman distribution [23]-[25]. Typically, the generated excited or dissociated species have much higher reactivity than neutral species at the ground state. Moreover, the main characteristic of non-thermal plasma is that the electrons in plasma zone have a higher energy than neutral gas having a relatively low temperature near room temperature.

The objective in this work was to investigate the ethylene epoxidation performance using a dielectric barrier discharge system by initially producing oxygen active species prior to reacting with ethylene. The effects of various operating parameters, including ethylene feed position, oxygen-to-ethylene feed molar ratio, applied voltage, input frequency, and feed flow rate on the ethylene epoxidation activity were examined.

II. EXPERIMENTAL

A. Reagent Gases for Reaction Experiments

Helium (HP grade), 40% ethylene balanced with helium, and 97% oxygen balanced with helium, used for this study were obtained from Thai Industrial Gas Co., Ltd.

B. Dielectric Barrier Discharge System

The experimental study of ethylene epoxidation was investigated in a parallel dielectric barrier discharge (DBD) reactor at ambient temperature and atmospheric pressure. The schematic of experimental setup for ethylene epoxidation reaction using the DBD system is shown in Fig. 1 The reactor configuration is shown in Fig. 2. The reactor sizes were 1.5 cm thickness \times 5.5 cm width \times 17.5 cm length for inner dimensions and 3.9 cm thickness \times 9.5 cm width \times 21.5 cm length for outer dimensions. Between the two electrodes, there was a dielectric glass plate. The gap distance between the two electrodes was fixed at 7 mm [26]. The AC input of 220 V and

50 Hz was converted to DC of about 70- 80 V by a DC power supply converter. For the second step, the DC was controlled through a 500 W power amplifier, which was connected to a Instek function generator to generate waveform and to amplify voltage and frequency. The signal of the alternating current was a sinusoidal waveform. For the final step, the generated

AC was passed through an input transformer to step up an output voltage. Thereafter, the variable output was transmitted to a high voltage current by nominal factor 130 times of low side (input). An Extech series 380801 power analyzer was used to measure current, frequency, and voltage at the low side of power supply unit.

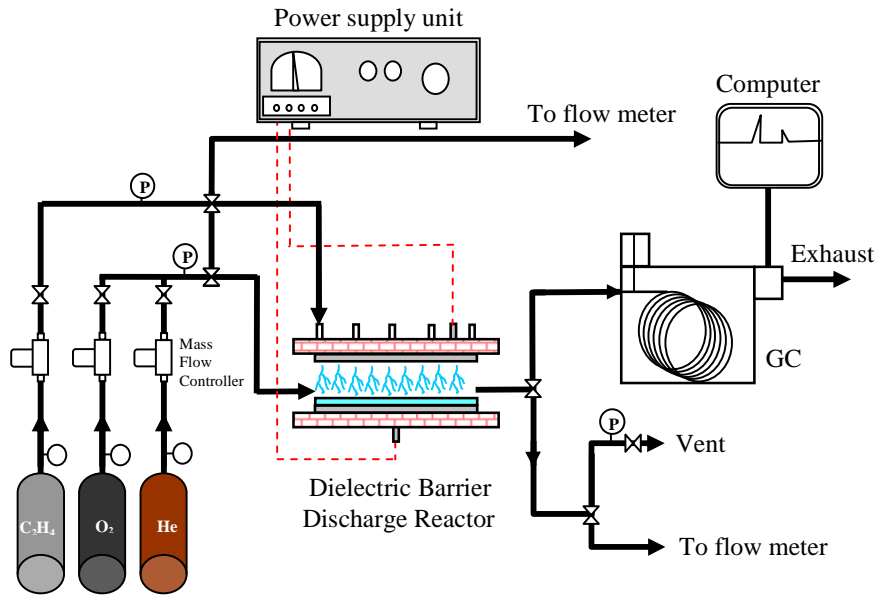

Fig. 1 Flow diagram of the dielectric barrier discharge plasma system

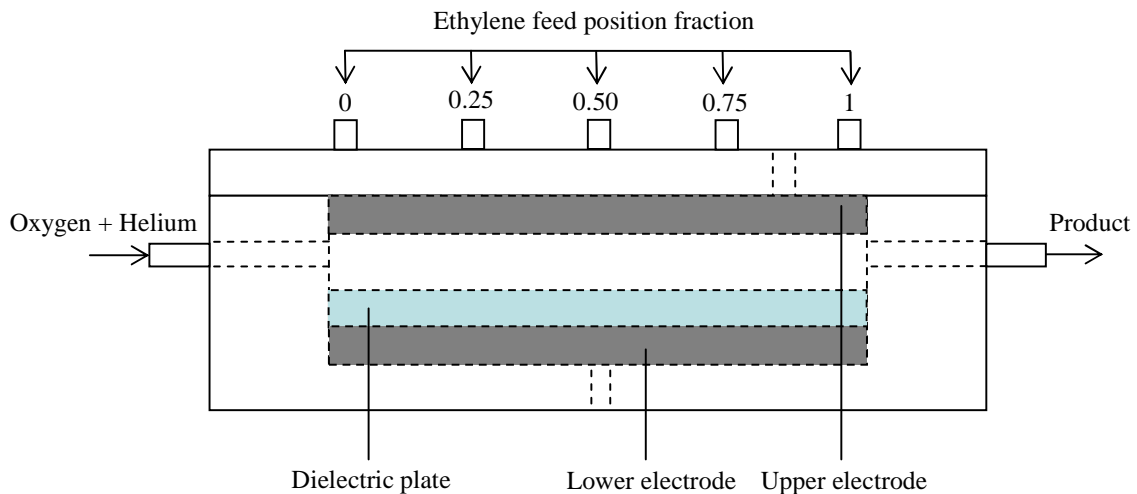

Fig. 2 Configuration of the dielectric barrier discharge reactor.

C. Reaction Experiments

The reactant gases (ethylene, oxygen, and helium) flowing through the reactor were controlled by a set of electronic mass flow controllers. Each reactant line had a 7 μm in-line filter before passing through the mass flow controller in order to trap any foreign particles. The reactor pressure was controlled via a needle valve. The outlet of reactor was either vented to the atmosphere via rubber tube exhaust or entered an on-line gas chromatograph (GC) to analyze the product gases. The moisture in the effluent gas was removed by a water trap before entering to the on-line GC. The GC was equipped with both a thermal conductivity detector (TCD) and a flame ionization detector (FID). For the TCD channel, a packed column (Carboxen 1000) was used for separating the product gases, which were H_2 , O_2 , CO , and CO_2 . For the FID channel, a capillary column (OV-Plot U) was used for the analysis of ethylene oxide (EO), C_2H_4 and other by-product gases, i.e. CH_4 , C_2H_6 , and C_3H_8 . The composition of the product gas stream was determined by the GC every 40 min. When the system reached steady state, an analysis of the outlet gas compositions was performed at least five times. The experimental data under steady state condition was averaged and then used to evaluate the process performance of the plasma system

D. Reaction Performance Assessment

To evaluate the system performance, the C_2H_4 and O_2 conversions and the selectivities for products, including EO, CO , CO_2 , H_2 , CH_4 , C_2H_6 , and traces of C_3 , were calculated. The conversions of C_2H_4 and O_2 were calculated from the following equation:

$$\% \text{ Reactant conversion} = 100 \times [(\text{mole of reactant in} - \text{mole of reactant out}) / \text{mole of reactant in}] \quad (1)$$

The product selectivity was calculated from the following equation:

$$\% \text{ Product selectivity} = [(\text{number of carbon or hydrogen atom in product}) \times (\text{moles of product produced})] / [(\text{number of carbon or hydrogen atom in ethylene}) \times (\text{moles of ethylene converted})] \times 100 \quad (2)$$

The ethylene oxide yield was calculated from the following equation:

$$\% \text{ Ethylene oxide yield} = (\% \text{ ethylene oxide selectivity}) \times (\% \text{ ethylene conversion}) / 100 \quad (3)$$

The power consumption was calculated in a unit of Ws per molecule of converted ethylene or per molecule of produced ethylene oxide using the following equation:

$$\text{Power consumption} = (P \times 60) / (N \times M) \quad (4)$$

where P = power (W), N = Avogadro's number = 6.02×10^{23} molecules/mol, M = rate of converted ethylene molecules in feed or rate of produced ethylene oxide molecules (mol/min).

III. RESULTS AND DISCUSSION

A. Effect of Ethylene Feed Position

The effect of ethylene (C_2H_4) feed position was initially studied in order to obtain the most suitable position for ethylene epoxidation reaction in the low-temperature DBD system. In this study, the ethylene feed position was varied in the fraction range of 0 to 1, while the feed molar ratio of $\text{O}_2/\text{C}_2\text{H}_4$ of 0.25:1, an applied voltage of 19 kV, an input frequency of 500 Hz, and a total feed flow rate of 50 cm^3/min were used as base conditions to operate the DBD system. The effect of ethylene feed position on the ethylene and oxygen conversion is shown in Fig. 3a, the EO selectivity and EO yield are shown in Fig. 3b and the selectivities for CO , CO_2 , H_2 , CH_4 , C_2H_6 , and C_3H_8 are shown in Fig. 3c. The conversion of oxygen was almost constant with increasing ethylene feed position fraction. However, the conversion of ethylene tended to increase with increasing ethylene feed position fraction ranging from 0 to 0.5. At a higher ethylene feed position fraction, the ethylene conversion tended to decrease, and it reached a minimum at the ethylene feed position fraction of 0.75. The increase in the ethylene feed position fraction slightly affected the EO selectivity, EO yield and reactant conversions, especially in the ethylene feed position fraction range between 0 to 0.5. The EO selectivity and EO yield were found to be the highest at the ethylene feed position fraction of 0.5 and decreased with further increasing ethylene feed position fraction. Furthermore, at a highest ethylene feed position fraction of 1, the selectivity for EO was the lowest. This can be explained in that a lower ethylene feed position fraction leads to more opportunity of ethylene molecule to be cracked before colliding with O_2 active species, whereas at a higher ethylene feed position fraction the ethylene has a short residence time for epoxidation reaction. The selectivities for CO , CO_2 , C_2H_6 , C_3H_8 and CH_4 tended to decrease, but in contrast, the selectivity for H_2 remained almost unchanged with increasing ethylene feed position. The selectivities for CO and CO_2 tended to increase in the studied range of ethylene feed position fraction from 0.5 to 1. The CO selectivity increased when the ethylene feed position fraction increased, and it reached a maximum at the ethylene feed position fraction of 0.75. Fig. 3d shows the power consumptions to convert an ethylene molecule and to produce an EO molecule at different ethylene feed position fractions. The power consumption per molecule of converted ethylene reached a minimum when the ethylene feed position fraction increased up to 0.5 and rapidly increased with further increasing feed position fraction up from 0.5 to 1. However, there was a significant increase in the power consumption per molecule of produced EO with further increasing ethylene feed position fraction, especially at a feed position fraction higher than 0.5. Hence, an ethylene feed position fraction of 0.5 was therefore selected for further investigation because it provided the highest EO selectivity and yield and the lowest power consumption per molecule of EO produced.

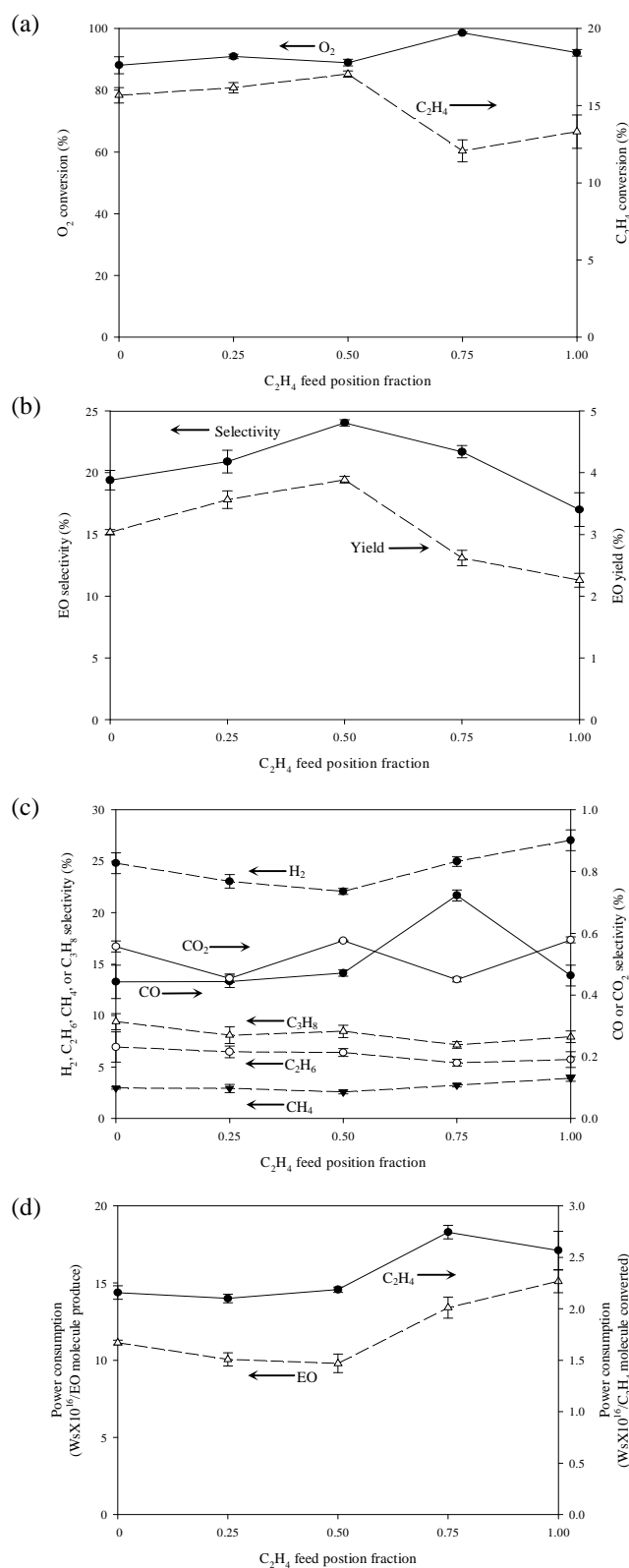

Fig. 3 (a) C₂H₄ and O₂ conversions, (b) EO selectivity and yield, (c) other product selectivities, and (d) power consumptions as a function of ethylene feed position fraction at an O₂/C₂H₄ feed molar ratio of 0.25:1, an applied voltage of 19 kV, an input frequency of 500 Hz, and total feed flow rate of 50 cm³/min

B. Effect of O₂/C₂H₄ Feed Molar Ratio

To determine the influence of the feed gas composition, the O₂/C₂H₄ feed molar ratio was next varied in the range of 0:1 to 0.5:1 (O₂-lean conditions), while the other operating parameters were fixed at a C₂H₄ feed position fraction of 0.5 (optimum condition), an applied voltage of 19 kV, an input frequency of 500 Hz, and total feed flow rate of 50 cm³/min. As shown in Fig. 4a, an increase in O₂/C₂H₄ feed molar ratio slightly affects the C₂H₄ and O₂ conversions, and the highest conversions of both reactants are obtained at an O₂/C₂H₄ feed molar ratio of 0.5:1. The explanation is that an increase in the molar ratio of O₂/C₂H₄ results in having more O₂ available to react with ethylene molecules, leading to higher ethylene conversion and O₂ conversion. The effect of the O₂/C₂H₄ feed molar ratio on EO selectivity and EO yield are shown in Fig. 4b. Both of them increased with increasing O₂/C₂H₄ feed molar ratio from 0.17:1 to 0.2:1 and rapidly decreased with further increasing O₂/C₂H₄ feed molar ratio greater than 0.2:1, suggesting that EO can be formed dominantly under the deficient O₂ condition. The highest EO selectivity and EO yield were found at an O₂/C₂H₄ feed molar ratio of 0.2:1. The effect of O₂/C₂H₄ feed molar ratio on the selectivities for other products is shown in Fig. 4c. The selectivities for H₂, CH₄, C₃H₈, and C₂H₆ tended to decrease, but in contrast, the selectivities for CO and CO₂ increased with increasing O₂/C₂H₄ feed molar ratio, as aforementioned. Interestingly, the CO and CO₂ selectivities increased when the O₂/C₂H₄ feed molar ratio increased, and they reached a maximum at a O₂/C₂H₄ feed molar ratio of 0.5:1. Under the studied conditions, the main products were CO and CO₂ with significant amounts of EO, H₂, CH₄, C₃H₈ and C₂H₆. The largest hydrocarbon, i.e. C₃H₈, was found in a very small fraction. The results can be explained by the fact that, both complete and partial oxidation reactions are controlled by the ratio of oxygen in the system. The decreases in the selectivities for these hydrocarbons and H₂ and the increase in the selectivities for CO and CO₂ with increasing oxygen fraction in feed clearly reveal that the oxidative dehydrogenation and coupling reactions unfavorably occur under O₂-rich conditions, as expected. Furthermore, at a very high O₂/C₂H₄ feed molar ratio of 0.5:1, the selectivity for EO dropped to zero level since this high O₂/C₂H₄ feed molar ratio induced the complete combustion to occur more favorably than the partial oxidation, as well as the epoxidation, indicating that the epoxidation reaction to produce EO is more likely to occur under O₂-lean conditions. The power consumptions required to convert C₂H₄ molecule and to produce EO molecule at different O₂/C₂H₄ feed molar ratios are shown in Fig. 4d. The power consumption per molecule of produced EO reached a minimum at an O₂/C₂H₄ molar ratio of 0.2:1, which corresponded well with the obtained highest EO selectivity. However, the power consumption per molecule of converted C₂H₄ remained almost unchanged in the O₂/C₂H₄ feed molar ratio range of 0.2:1-0.25:1, but then slightly decreased with increasing O₂/C₂H₄ feed molar ratio to 0.5:1, at which the lowest EO selectivity was observed.

IV. CONCLUSIONS

The epoxidation reaction of ethylene was investigated in the low-temperature DBD plasma system at different ethylene feed position fractions and feed molar ratios of O_2/C_2H_4 . The highest EO selectivity of 34.3% and the highest EO yield of 5.28% were obtained when the DBD was operated at an ethylene feed position fraction of 0.5, an O_2/C_2H_4 feed molar ratio of 0.2:1, an applied voltage of 19 kV, an input frequency of 500 Hz, and a total feed flow rate of $50 \text{ cm}^3/\text{min}$. At these best conditions, the power consumptions to break down each C_2H_4 molecule and to create an EO molecule were found to be $2.11 \times 10^{-16} \text{ W}$ /molecule of C_2H_4 converted and $6.34 \times 10^{-16} \text{ W}$ /molecule of EO produced.

ACKNOWLEDGMENTS

The authors would like to gratefully acknowledge the National Excellence Center for Petroleum, Petrochemicals, and Advance materials, Chulalongkorn University, Thailand.

REFERENCES

- [1] P.P. McClellan, *Ind. Eng. Chem.* 42 (1950) 2402.
- [2] S. Matar, M.J. Mirbach, H.A. Tayim, *Catalysis in Petrochemical Processes*, Kluwer Academic Publishers, Dordrecht, The Netherlands, 1989.
- [3] J.G. Serafin, A.C. Liu, S.R. Seyedmonir, *J. Mol. Catal. A: Chem.* 131 (1998) 157.
- [4] K.L. Yeung, A. Gavriilidis, A. Varma, M.M. Bhasin, *J. Catal.* 174 (1998) 1.
- [5] W.S. Epling, G.B. Hoflund, D.M. Minahan, *J. Catal.* 171 (1970) 490.
- [6] S.N. Goncharova, E.A. Paukshtis, B.S. Bal'zhinimaev, *Appl. Catal. A: Gen.* 126 (1995) 67.
- [7] M.A. Pena, D.M. Carr, K.L. Yeung, A. Varma, *Chem. Eng. Sci.* 53 (1998) 3821.
- [8] D. Lafarga, A. Varma, *Chem. Eng. Sci.* 55 (2000) 749.
- [9] E.A. Podgornov, I.P. Prosvirin, V.I. Bukhtiyarov, *J. Mol. Catal. A: Chem.* 158 (2000) 337.
- [10] A. Ayame, Y. Uchida, H. Ono, M. Miyamoto, T. Sato, H. Hayasaka, *Appl. Catal. A: Gen.* 244 (2003) 59.
- [11] M.C.N. Amorim de Carvalho, F.B. Passos, M. Schmal, *J. Catal.* 248 (2007) 124.
- [12] S. Lincic, J. Jankowiak, M.A. Barteau, *J. Catal.* 224 (2004) 489.
- [13] J.T. Jankowiak, M.A. Barteau, *J. Catal.* 236 (2005) 366.
- [14] J.T. Jankowiak, M.A. Barteau, *J. Catal.* 236 (2005) 379.
- [15] J.C. Dellamorte, J. Lauterbach, M.A. Barteau, *Catal. Today* 120 (2007) 182.
- [16] P.V. Geenen, H.J. Boss, G.T. Pott, *J. Catal.* 77 (1982) 499.
- [17] N. Toreis, X.E. Verykios, *J. Catal.* 108 (1987) 161.
- [18] R. Herrera, A. Varma, E. Martinez, *Stud. Surf. Sci. Catal.* 55 (1990) 717.
- [19] D.I. Kondarides, X.E. Verykios, *J. Catal.* 158 (1996) 363.
- [20] S. Rojluetchai, S. Chavadej, J.W. Schwank, V. Meeyoo, *Catal. Commun.* 8 (2007) 57.
- [21] S. Chavadej, S. Rojluetchai, J.W. Schwank, V. Meeyoo, *Mechanisms in Homogeneous and Heterogeneous Epoxidation Catalysis*, Elsevier, 2008, p. 283.
- [22] B. Eliasson, U. Kogelschatz, *IEEE Trans. Plasma Sci.* 19 (1991) 1063.
- [23] H. Suhr, H. Pfreundschuh, *Plasma Chem. Plasma Process.* 8 (1988) 67.
- [24] L.A. Rosacha, G.K. Anderson, L.A. Bechtold, J.J. Coogan, H.G. Heck, M. Kang, W.H. McCulla, R.A. Tennant, P.J. Wantuck, *NATO ASI Ser. Part B* (1993) 34.
- [25] P. Patino, F.E. Hernandez, S. Rondon, *Plasma Chem. Plasma Process.* 15 (1995) 159.
- [26] T. Suttikul, T. Srethawong, H. Segiguchi, S. Chavadej, *Plasma Chem. Plasma Process.* 31 (2011) 290.

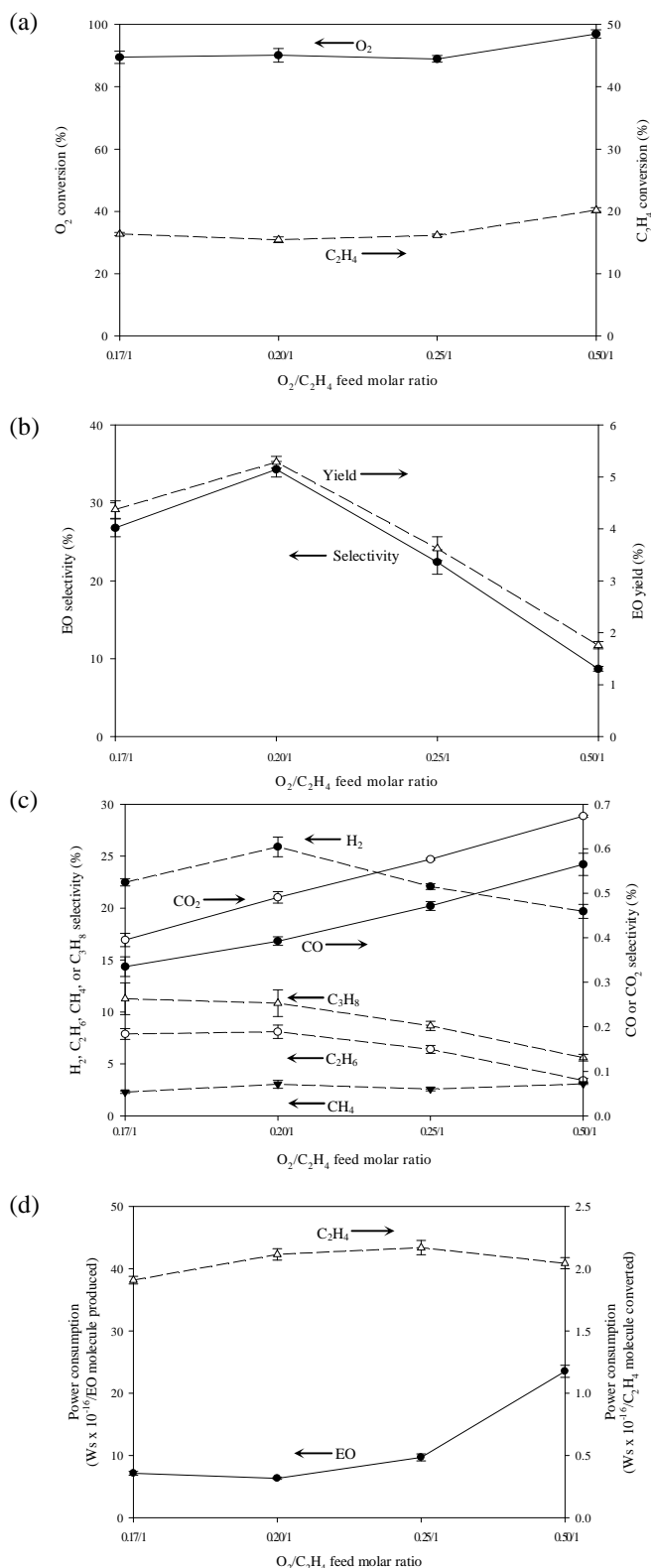

Fig. 4 (a) C_2H_4 and O_2 conversions, (b) EO selectivity and yield, (c) other product selectivities, and (d) power consumptions as a function of O_2/C_2H_4 feed molar ratio at an ethylene feed position fraction of 0.5, an applied voltage of 19 kV, an input frequency of 500 Hz, and total feed flow rate of $50 \text{ cm}^3/\text{min}$